

Engineering design of the platform edge screens for the Elizabeth line's tunnel stations

Julian Birbeck
CEng, MStructE
Associate, Atkins, UK

Rosemary Smiley
MEng
Structural Engineer, Atkins, UK

George Stowell
RIBA, MRlA
C100 Framework Contract
Manager, Atkins, UK

Ed Newman-Sanders
CEng, MICE
Technical Director, Atkins, UK

Synopsis

This paper covers the engineering design of the platform edge screens for five Elizabeth line tunnel stations in central London. Full-height platform edge screens are a signature feature of the Elizabeth line's station platforms, and their design presented many challenges. To gain maximum uniformity, the edge screens were developed as a common reference design, which was then issued to each of the station contractors.

The paper describes the technical challenges from the point of view of a structural engineer, but in doing so, it draws in interfaces with disciplines as diverse as tunnel ventilation, electrical engineering, and rolling stock procurement. The reference design approach allowed unique features of the platform edge screens to be prototyped and tested before construction.

stations with platforms in basement boxes, such as Paddington and Canary Wharf. The PES-frame design for the latter presented a different set of constraints and is not covered in this paper.

From street level, the scale of Elizabeth line platforms and the associated screens may not be apparent. The length of a single Elizabeth line PES is up to twice that of an existing London tube platform. Underground platforms on this scale will provide a dramatic new experience for London commuters and, as such, the screens can claim to have as significant an impact on London's cityscape as a new skyscraper (Figure 1).

Nine-car Elizabeth line trains are over 200m long, and each platform has some additional publicly accessible length to allow for longer trains in future. Consequently, there is over 0.5km of screen required at each station and the PES-frames described in this paper extend for over 2.5km in total. The PES-frame is designed around a 3m module, so there are over 830 of these modules across the network.

Contractual set-up

The PES was developed as a cross-station design package (see McClements, 2015 and Moxon and Atherton, 2015 for a more detailed discussion of the benefits of this approach)^{1,2}. The design was undertaken as part of the Crossrail Architectural Component Design contract (designated 'C100'), comprising Atkins, Grimshaw, GIA Equation and Maynard, who designed and prototyped the line-wide sub-surface station fit-out, and surface station visual identity.

Components were drawn, performance-specified, mocked up, prototyped and tested as generic solutions. Once approved, these common solutions were passed on for station-specific design, manufacture and installation.



Figure 1
New landmark – illustration of length of single PES set against London skyline

Introduction

The term platform edge screen (PES), as used in this paper, describes a complete assembly, comprising screen doors, an upper 'service wall' supporting lighting, communications and cabling, plus a smoke-extraction duct positioned over the track. The term PES-

frame is used to describe the structural frame that supports all these elements. This PES-frame design applies to five stations: Bond Street, Tottenham Court Road, Farringdon, Liverpool Street and Whitechapel. These are the Elizabeth line stations with platforms in tunnel bores, as opposed to

- 1 PES Post
- 2 Vierendeel Truss
- 3 Top Alignment Beam
- 4 Side Bracket
- 5 Smoke Plenum
- 6 Self Tapping Fixings into SCL
- 7 Zone for PSD (By others)

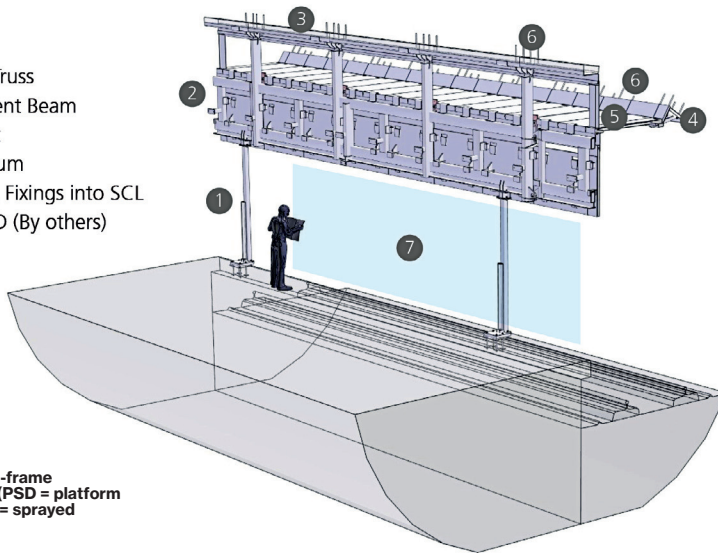

Figure 2
BIM model of PES-frame reference design (PSD = platform screen door; SCL = sprayed concrete lining)

The platform screen doors, including the glazed infill panels, are specialised mechanical components and were delivered by a separate contract (Figure 2).

A part of the overall strategy was to undertake stakeholder engagement with the organisations operating the stations and railway. This involved reviewing design drawings, three-dimensional (3D) building information models (BIM), and physical prototypes. Thereafter, a coordinated access and maintenance strategy was issued to station contractors alongside the RIBA Stage F1 design (according to the RIBA Plan of Work 2007): the objective being to create a harmonised maintenance strategy.

Purpose of platform edge screens

Platform edge structures are uncommon in the UK, being first used on the Jubilee line extension in 1999. Nonetheless, such structures can be found on many metro systems and fall into three categories (Figure 3):

- **Platform edge doors** are balustrade-height edge structures with automatic doors aligned to the train doors. Their sole function is to prevent passengers falling onto the track.
- **Platform screen doors** are doorway-height structures with automatic doors aligned to the train. They have the same safety function as platform edge doors, also providing a degree of screening to passengers from air movement.
- **Platform edge screens** are platform-to-ceiling structures providing more extensive screening than platform screen doors. They also separate the platform and track environments.

"THE PLATFORM EDGE SCREEN WAS DEVELOPED AS A CROSS-STATION DESIGN PACKAGE"

in central London was removed.

The simplest approach to design the PES would be to collect all station systems on the platform side and all rail systems on the trackside. Stations require extraction ducting for the full length of the platform – both for the day-to-day managing of platform ventilation, but critically also to provide smoke extraction in the event of a fire.

The decision was taken to place the extraction duct over the track (Figure 4),

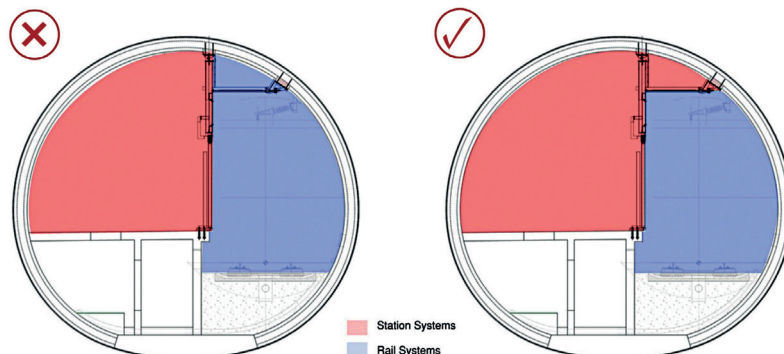

Figure 3
Classification of platform edge structures

Simple Approach: Station and rail systems split on platform edge

More Challenging Approach: Stations systems extend over track

Figure 4
Platform tunnel space planning: station and rail zones

For the Elizabeth line, the early decision to use a PES transformed the tunnel ventilation strategy. Since air leakage through stations was effectively eliminated, the need for six additional ventilation shafts and head-houses

allowing the platform space to take on a unique character and resulting in a very different passenger experience. The tunnel cladding curves over the passengers' heads to the tunnel apex, with all lighting, signage,

public address systems and associated cabling then located on the vertical face of the PES above the screen doors. Light from the lightboxes reflects off the tunnel cladding to create a soft, diffuse ambience (Figure 5).

Consequently, the structural engineer is in a pivotal position: designing a structure which is not only critical to the overall master-planning and land-take of the railway, but which also underpins the platform architectural concept and the passengers' experience.

Development of structural diagram

There are two alternative approaches to designing a PES-frame: it can either be suspended from the tunnel crown above; or propped from the platform edge below. The choice between these two approaches is not straightforward, due to conflicting design constraints. Firstly, during fit-out, the system-wide contract passes through each platform with track-laying plant requiring an unobstructed zone along the platform edge. Secondly, Elizabeth line stations differ from existing underground stations in their use of sprayed concrete lining reinforced with fibre³ for profile stabilisation. The sprayed lining has limited capacity for point loads.

Sprayed linings are not suited to the accurate placing of reinforcement. Hence, rebar is used sparingly, only at critical junctions. Furthermore, multistage lining build-up raises a risk of delamination between layers under radial point loads. Overall, it was judged that the concrete lining could not be designed with sufficient long-term capacity to support a suspended PES-frame in its entirety. The alternative was to support the PES from below with posts placed onto the platform edge; however, posts passing down to platform level would need to coordinate with the door positions on the screen doors. At the time of design and initial tunnel construction, the rolling stock had not been ordered; moreover, for competitive tender, train bids were placed with multiple suppliers, each with different door configurations. Even when this procurement sequencing issue was resolved, there remained a need to provide future flexibility in the PES, including the option to extend trains in the future with different door configurations.

The chosen structural diagram was therefore an adaptable hybrid, which could function in a suspended or propped configuration in the temporary and permanent conditions, respectively. A sequence of fixings is placed into the tunnel crown at 3m centres; these fixings provide vertical and horizontal restraint temporarily, but revert to horizontal restraint only in the permanent condition, in



Figure 5 Elizabeth line platform environment

CROSSRAIL LTD

"THE CHOSEN STRUCTURAL DIAGRAM WAS THEREFORE AN ADAPTABLE HYBRID"

which the PES-frame is supported from the platform. The propped configuration needs to include sufficient articulation to allow for deformations in the tunnel cross-section, known as tunnel 'squat' (Figure 6).

The crown fixings support a continuous Vierendeel truss with a 1.5m module. The truss is designed so that it may be supported at any point with pin-ended posts onto the platform edge below (subject to some basic setting-out constraints). Horizontal props on a 3m module provide lateral restraint. To complete the system, the smoke duct soffit is formed in precast planks, spanning from the top of the truss onto a continuous side-bracket, fixed to the sprayed concrete lining on the track side.

This structural arrangement provides alternative load paths, giving the PES-frame an inherent robustness. Should a PES-post be accidentally removed, the slotted-hole connections at the crown would reach their limit of travel and the frame would revert (short term) to a hanging structure.

Given the length of the PES, longitudinal movement was an additional consideration. Expansion joints are provided at 15m centres

along the platform. Between these movement joints, it was necessary to provide moment-splices in the continuous truss, allowing it to be installed in 3m, 6m or 9m lengths (Figure 7). Setting-out rules were devised

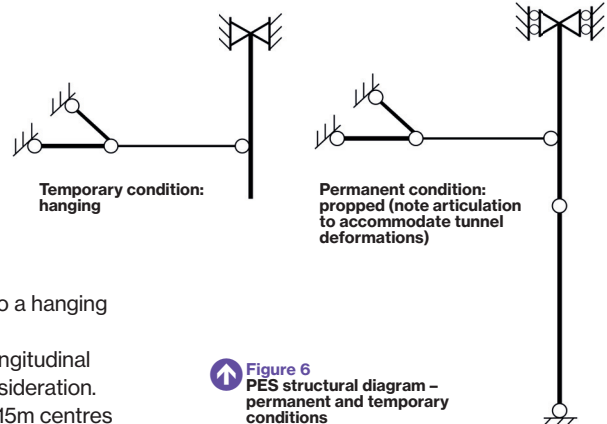
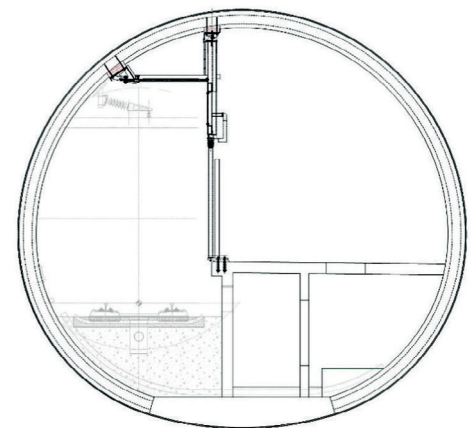

Figure 6 PES structural diagram – permanent and temporary conditions

PATRYK TOKAREK/YOUTUBE



➔ Figure 7
6m length of
PES Vierendeel
truss being
lifted into place
at Farringdon
Station (note
top and side
alignment
beams already
in position)

Lindner Installation works : Patryk Tokarek : YouTube <https://www.youtube.com/watch?v=VUnUDAgOraI>

interfaces between the structural frame and the supported elements, this too would need to be erected to cladding tolerances. Consequently, the connection into the sprayed concrete lining was required to take up the major portion of the tolerance.

The solution was to use grout infills running longitudinally along the tunnel at the two upper connections into the sprayed concrete lining: the top connection at the tunnel crown, and the side connection at the trackside edge of the smoke plenum. A folded-plate alignment beam was placed at the apex of the tunnel, and a similar folded-plate detail was used for the side bracket (Figure 8). In this way, the erector was required to line and level these elements, which were delivered to site in 6m or 3m lengths. Once positioned within tolerance, grout infills were poured and

allowing the reference design to be adapted to any permutation of rolling stock and train stopping position.

The PES is not fire-rated to withstand a full train fire, but it does need to function in the event of a small baggage fire. To this end, computational fluid dynamic analysis was undertaken, confirming a need for the PES to resist smoke temperatures of 200°C for up to one hour. This temperature does not critically affect steel strength, but does create a significant degree of thermal expansion, which needs to be accommodated at the movement joints.

Tolerances

The sprayed concrete lining has a large construction tolerance envelope of 100mm, whereas the screen doors and the cladding fixtures have an installation tolerance of ±5mm. It was thus clear that due to multiple

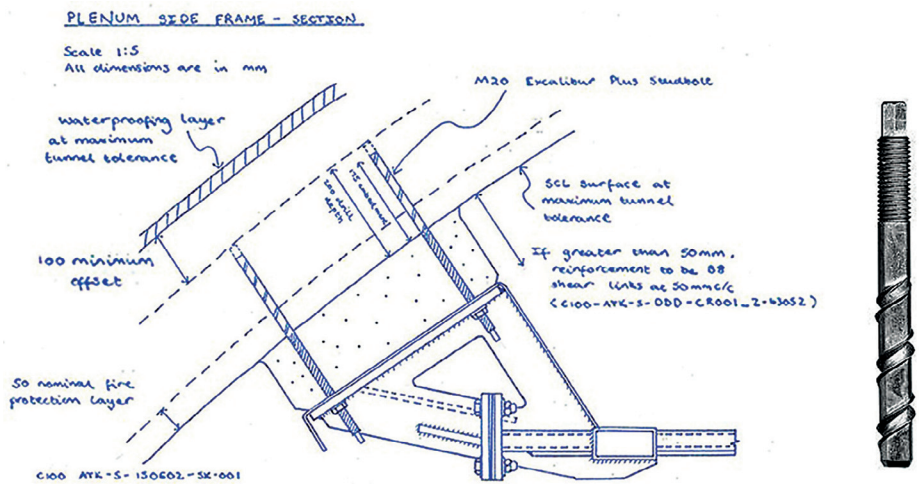

➔ Figure 8
Design development sketch showing grout infill, stud anchors and self-tapping threaded M20 stud-anchor

the required tolerances were locked in for the subsequent frame erection.

As there are large tolerances involved at the sprayed concrete lining interface, the anchors needed to be through-fixings, allowing the PES brackets to be offered up, lined and levelled, with holes drilled using the brackets as templates. The anchors were threaded studs, with two nuts clamping to allow the PES bracket to be held firmly in position while grout was poured.

Anchor choice was also influenced by the Boston Interstate 90 tunnel ceiling collapse of 2006 (consequent on creep in chemical fixings). Crossrail's technical standards prohibit such anchors working in direct tension in overhead fixings. The adopted anchors were therefore self-tapping anchors, used extensively for secondary fixings on the Channel Tunnel Rail Link. These offered the advantage of achieving full shear and tension capacity immediately when screwed into

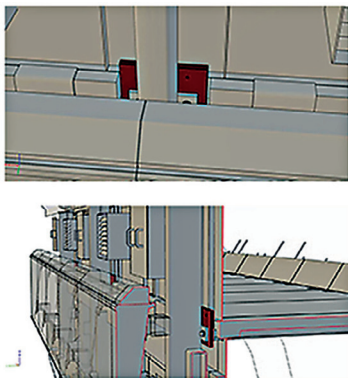

➔ Figure 9
BIM model used to develop access and maintenance strategy

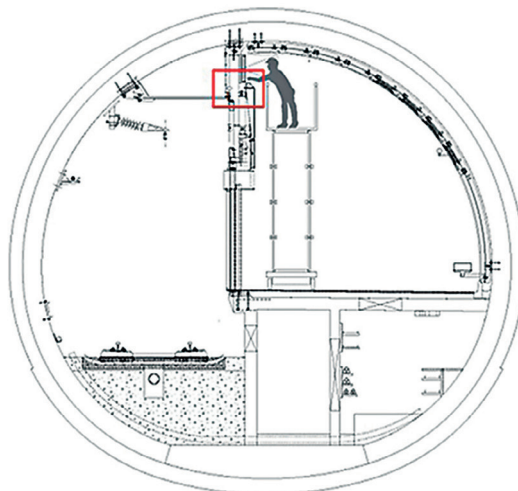

position, without the need for any subsequent operation or curing time. To ensure that delamination in the tunnel lining would not occur, and that the threaded anchors would not loosen or fatigue, Crossrail commissioned testing at Imperial College London. A testing rig was designed to replicate the connection between the PES-frame and sprayed concrete lining and the anchors were subjected to a cyclic load, representative of 10 years in service.

Durability, design life, and maintenance

The permanent and variable loads applied to the PES are relatively small, compared to loads on other elements of station structure. On the platform elevation, the PES is required to support lighting, signage and other items of equipment, totalling 1kN/m² (i.e. a typical cladding load). The smoke plenum soffit, formed in precast concrete, weighs 2.2kN/m² on plan.

As far as variable actions are concerned, crowd load is represented by a 3.0kN/m line load. In addition, piston loads from train movement create pressure changes, with a typical value of 0.8kN/m², and an extreme case of 1.2kN/m². As such, the static load capacity of the PES-frame does not present an engineering challenge. The key factor, however, is fatigue: each train movement creates a complete reversal of piston pressure. Given the operational timetable of the network, with trains every two minutes at peak times, there are over 24M fatigue cycles during the 120-year design life. Consequently,

Figure 10 Summary of earthing and bonding strategy, and need for electrical isolation within PES-frame

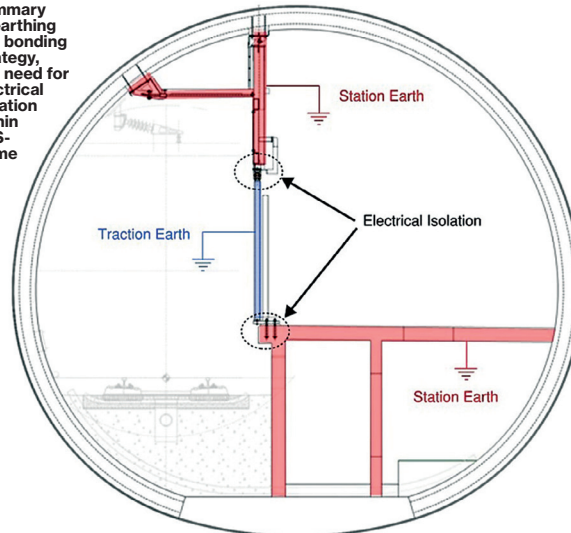

with locking washers. To aid inspection, all connections were designed with the bolts visible, a condition verified by using a 3D BIM model (Figure 9). The corrosion protection system needed to be a minimum-maintenance solution. Stainless steel structure was considered, but adequate life was achieved from a cheaper galvanised finish (typically 140µm).

Electrical isolation

Electric train traction relies on the return current from the overhead lines passing through the rails. Over the distances involved, rails have significant electrical resistance, with the net result that

"EARTH VOLTAGE ON A TRAIN IS 'FLOATING' RELATIVE TO ITS SURROUNDINGS"

fatigue governed the design and detailing of welded connections within the PES-frame.

Another design challenge created by the Elizabeth line's running schedule is the demand for ongoing inspection and maintenance. This task is to check the steel and corrosion protection condition and assure nuts remain tight – albeit all nuts are secured

earth voltage on a train is 'floating' relative to its surroundings and can be in the order of 50V.

This is of no concern when the train is moving and the passengers are separated from the surroundings. However, when the train stops, it is imperative that passengers cannot touch the train or any surrounding metallic infrastructure located on a separate electrical earth. The platform edge structure therefore must be electrically bonded to the adjacent rails and isolated from the surrounding station earthing system.

This is achieved by electrically isolating the screen doors and the adjacent PES-posts from the remainder of the PES-frame above and the platform edge rebar below (Figure 10). The latter isolation was achieved by locally reinforcing the platform edge with non-conducting glass fibre-reinforced plastic rebar.

The former isolation, however, presented a challenge. The screen doors and the PES-frame form a wall bounding the platform space. As such, they are subject to the Sub-Surface Railway Stations Regulations⁴, which originated in response to the Kings Cross underground fire of 1987. The regulations stipulate that any material used in the construction of a wall in a public place must be of limited combustibility – and this cannot be achieved with a polymer. Consequently,

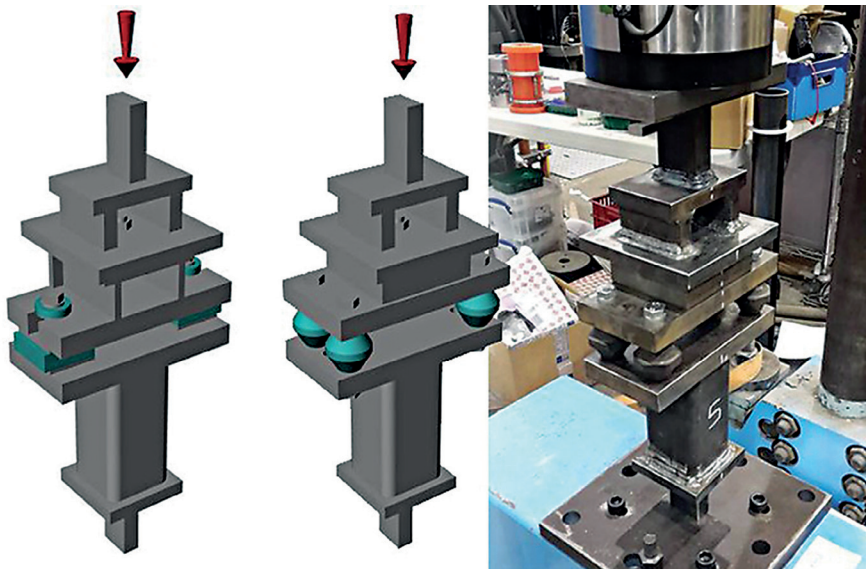

Figure 11 Isolator testing rigs



Figure 12
Installation of PES

three different isolator materials were shortlisted and their performance under cyclic load tested at Imperial College London. Mica-glass and Macor® – both machined glass products – and ceramit-14 – a ceramic – underwent cyclic load testing in rigs representative of their positioning in the PES-frame (Figure 11). The mica-glass performed best and was the material selected for the isolating components. It is anticipated these will require periodic replacement and frame detailing was developed with this in mind.

Construction and operations

The C100 design team prepared the PES-frame reference design for a generic, straight run of tunnel platform to RIBA Stage F1. As such, the station contractors (Figure 12) were presented with an assured steelwork design, including full connection design, as well as precast planks for the plenum soffit with full reinforcement design. In this way, C100 created a major saving in time and cost through common design and coordination effort, compared to each contractor working up a PES themselves, and even greater value in a common safety regime and maintenance processes.

Conclusions and lessons learned

When the Elizabeth line opens to the public in December 2018, there will be a completely new subsurface environment on the London transport network. The 250m long platforms with 5m unobstructed headroom will change passengers' expectations of subsurface rail, made possible by the gathering of lighting, signage, communications and services distribution onto the vertical plane of the PES, with the smoke-extraction plenum

"THE STATION CONTRACTORS WERE PRESENTED WITH AN ASSURED STEELWORK DESIGN"

concealed behind.

The delivery of the PES design by the C100 Architectural Component Design package brought undoubted design and maintenance efficiencies. Given the complexities of the interfaces with the tunnel lining, electrical isolation, coordination with the door locations, and offsite testing, the level of design supervision required would have been significantly greater had these issues been tackled independently by the station teams.

From the structural engineer's perspective, the PES design is intriguing. A cursory glance at the structural spans and the applied loads suggests that the PES is a simple element of secondary steel. Challenges have arisen, however, from the interfaces with other systems and are inherent in a heavily serviced, spatially constrained railway. The key to unlocking these challenges has been a structure with built-in flexibility. Adaptable geometry allows the location of support posts to be varied, and adaptable load paths allow the structure to be hung as well as propped. In this respect, the development of such 'smart' structural components, with parameters that can be 'flexed' to suit local, temporary or future conditions, may become increasingly common for large infrastructure projects.

Acknowledgements

The authors are grateful to Dr Sunday Popo-Ola, who oversaw the material testing of the isolator components and threaded anchors at Imperial College London, and led the subsequent analysis of the results.

Atkins is a part of SNC-Lavalin's Engineering, Design and Project Management business.

REFERENCES

- ▶1) McClements N. (2015) 'The Value of Common Design – C100 Crossrail Architectural Components', In: Black M., Dodge C. and Lawrence U. (eds.) *Crossrail Project: Infrastructure design and construction*, London: ICE Publishing, pp. 59–69
- ▶2) Moxon S and Atherton S. (2015) 'The Importance of Construction Mock-ups and Trials', In: Black M., Dodge C. and Lawrence U. (eds.) *Crossrail Project: Infrastructure design and construction*, London: ICE Publishing, pp. 45–57
- ▶3) Coughlan D., Diez R., Comins J. and Stärk A. (2017) 'Crossrail project: use of sprayed concrete tunnel linings on London's Elizabeth line', *Proc. ICE Civ. Eng.*, 170 (5), pp. 39–46
- ▶4) *The Fire Precautions (Sub-surface Railway Stations) (England) Regulations 2009*, SI 2009/782

HAVE YOUR SAY

To comment on this article:

- ▶ email Verulam at tse@istructe.org
- ▶ tweet @IStuctE #TheStructuralEngineer