

This document is shared for the purposes of learning legacy. It is a snapshot in time and hence many of the links within the document will become obsolete over time. Some links/document references will refer to a document storage location that isn't accessible. Users should refer to the learning legacy website where these documents may be published separately.



# Bond Street Station Legion Modelling Report Stage E – Final Report

**Document Number: C132-WSP-T3-RGN-C125-50007**

**Document History:**

Revision:	Date:	Prepared by:	Authorised by:	Approved by:	Reason for Revision:
3.0	24-11-11	[REDACTED]	[REDACTED]	[REDACTED]	Issue for Review
		[REDACTED]	[REDACTED]	[REDACTED]	

CROSSRAIL REVIEW AND ACCEPTANCE STATUS	
This decal is to be used for submitted documents requiring acceptance by CRL.	
<input checked="" type="checkbox"/>	Code 1. Accepted. Work May Proceed
<input type="checkbox"/>	Code 2. Not Accepted. Revise and resubmit. Work may proceed subject to incorporation of changes indicated
<input type="checkbox"/>	Code 3. Not Accepted. Revise and resubmit. Work may not proceed
<input type="checkbox"/>	Code 4. Received for information only. Receipt is confirmed
Reviewed/Accepted by:(signature)	[REDACTED] <i>12<sup>th</sup> Dec 2011</i>
Print Name:	[REDACTED] Date:
Acceptance by CRL does not relieve the designer/supplier from full compliance with their contractual obligations and does not constitute CRL approval of design, details, calculations, analyses, test methods or materials developed or selected by the designer/supplier.	

**Document History:**

This document contains proprietary information. No part of this document may be reproduced without prior written consent from the Chief Executive of Crossrail Ltd.

**Distribution List**

Distribution List		
Copy Number	Holder	Position
1	[REDACTED]	CRL Project Engineer
2	[REDACTED]	CRL Railway Operations
3	[REDACTED]	CRL Senior Transport Planner
4	[REDACTED]	CRL Architect
5	[REDACTED]	CRL Assistant Transport and Pedestrian Planner
6	[REDACTED]	C132 Lead Engineer
7	[REDACTED]	C132 Delivery
8	[REDACTED]	C132 Traffic Manager
9	[REDACTED]	C132 Senior Pedestrian Modelling Engineer
10	[REDACTED]	C132 Architectural Design Manager
11	[REDACTED]	C132 Lead Architect
12	[REDACTED]	C132 Structural Design Manager
13	[REDACTED]	C132 Lead Fire Engineer
14	[REDACTED]	C132 Fire Engineer
15	[REDACTED]	C132 Engineering Safety Manager
16	[REDACTED]	C132 Lead Construction Planner
17	[REDACTED]	C132 Lead MEP Engineer



## Contents

Distribution List .....	2
Record of Document Amendments.....	3
<b>1 Introduction .....</b>	<b>11</b>
1.1.1 Background and History .....	11
1.1.2 LU Audit of Legion Model Files.....	12
1.1.3 Purpose of Report .....	13
1.1.4 Model Scenarios .....	15
1.1.5 Model Specification .....	15
1.1.6 Modelling Standards.....	15
<b>2 Data Input.....</b>	<b>16</b>
2.1.1 Introduction.....	16
2.1.2 Stage E design models: 2026 pedestrian demand .....	16
2.1.3 Stage E design models: 2026+28% pedestrian demand .....	17
2.1.4 Peak Time Periods.....	18
<b>3 Station Layout .....</b>	<b>19</b>
3.1.1 Introduction.....	19
3.1.2 Corridor Widths .....	23
<b>4 Legion Modelling.....</b>	<b>29</b>
4.1.1 Introduction.....	29
4.1.2 Level of Service .....	29
4.1.3 Definition of Fruin LoS for Walking.....	30
4.1.4 Definition of Fruin LoS for Queuing .....	31
4.1.5 Ticket Gateline .....	32
Hanover Square .....	32
Davies Street.....	33
4.1.6 Acceptance Criteria for Legion Modelling .....	34
4.1.7 AM Peak 2026 Mean Density Maps .....	34
Intermediate Level .....	37
Platform Level .....	38
4.1.8 AM Peak 2026+28% Density Maps .....	41
Intermediate Level .....	44
Platform Level .....	45
4.1.9 PM Peak 2026 Density Maps .....	48
Intermediate Level .....	51
Platform Level .....	52
4.1.10 PM Peak 2026+28% Density Maps .....	54
Intermediate Level .....	57
Platform Level .....	60
4.1.11 Summary .....	63
<b>5 Breakpoint Modelling Results .....</b>	<b>64</b>
5.1.1 Introduction.....	64
5.1.2 Intermediate Level Results.....	64
5.1.3 Platform Level Results .....	72



<b>6 Summary</b> .....	<b>76</b>
6.1.1 Conclusions.....	76
Appendix A – AM Peak 2026 Cover Sheet.....	77
Appendix B – PM Peak 2026 Cover Sheet.....	78
Appendix C – AM Peak 2026+28% Cover Sheet.....	79
Appendix D – PM Peak 2026+28% Cover Sheet.....	80
Appendix E – AM 2026 Density Maps.....	81
Appendix F – AM 2026+28% Density Maps.....	106
Appendix G – PM 2026 Density Maps.....	131
Appendix H – PM 2026+28% Density Maps.....	156
Appendix I – Cross Section CAD Drawings.....	181
Appendix J – Stage E Auto CAD Drawings.....	187
Appendix K – LU Audit.....	193
Appendix L – Scheme History.....	195
Appendix M – Breakpoint Modelling.....	196
Appendix N – Fire Escape Stairs.....	197

Learning Legacy Document

## List of Figures

Figure 3.1 – Hanover Square Ticket Hall Stage E Design Layout.....	19
Figure 3.2 – Davies Street Ticket Hall Stage E Design Layout .....	20
Figure 3.3 – Intermediate Level Stage E Design Layout.....	21
Figure 3.4 – Platform Level Stage E Design Layout .....	22
Figure 3.5 – Cross Passageway.....	23
Figure 3.6 – LU Passageway Effective Width .....	24
Figure 3.7 – Western Passageway to Lifts.....	25
Figure 3.8 – Eastern Passageway to Lifts.....	26
Figure 3.9 – Lower Concourse Passageway .....	27
Figure 3.10 – Platform.....	28
Figure 4.1 – Formula for Calculating the Number of Ticket Gates (LU 1-371).....	32
Figure 4.2 - AM Peak 2026 Stage E Design Hanover Square Ticket Hall Cumulative Mean Density Walking.....	35
Figure 4.3 - AM Peak 2026 Stage E Hanover Square Ticket Hall Cumulative Mean Density Queuing.....	35
Figure 4.4 - AM Peak 2026 Stage E Design Davies Street Ticket Hall Cumulative Mean Density Walking .....	36
Figure 4.5 - AM Peak 2026 Stage E Design Davies Street Ticket Hall Cumulative Mean Density Queuing.....	36
Figure 4.6 - AM Peak 2026 Stage E Design Intermediate Level Cumulative Mean Density Walking .....	37
Figure 4.7 - AM Peak 2026 Stage E Design Intermediate Level Cumulative Mean Density Queuing.....	37
Figure 4.8 - AM Peak 2026 Stage E Design Platform Level Cumulative Mean Density Walking.....	38
Figure 4.9 - AM Peak 2026 Stage E Design Platform Level Cumulative Mean Density Queuing .....	39
Figure 4.10 - AM Peak 2026+28% Stage E Design Hanover Square Ticket Hall Cumulative Mean Density Walking.....	42
Figure 4.11 - AM Peak 2026+28% Stage E Hanover Square Ticket Hall Cumulative Mean Density Queuing.....	42
Figure 4.12 - AM Peak 2026+28% Stage E Design Davies Street Ticket Hall Cumulative Mean Density Walking.....	43
Figure 4.13 - AM Peak 2026+28% Stage E Design Davies Street Ticket Hall Cumulative Mean Density Queuing.....	43
Figure 4.14 - AM Peak 2026+28% Stage E Design Intermediate Level Cumulative Mean Density Walking .....	44

Figure 4.15 - AM Peak 2026+28% Stage E Design Intermediate Level Cumulative Mean Density Queuing.....	44
Figure 4.16 - AM Peak 2026+28% Stage E Design Platform Level Cumulative Mean Density Walking .....	45
Figure 4.17 - AM Peak 2026+28% Stage E Design Platform Level Cumulative Mean Density Queuing.....	46
Figure 4.18 - PM Peak 2026 Stage E Design Hanover Square Ticket Hall Cumulative Mean Density Walking.....	49
Figure 4.19 - PM Peak 2026 Stage E Hanover Square Ticket Hall Cumulative Mean Density Queuing.....	49
Figure 4.20 - PM Peak 2026 Stage E Design Davies Street Ticket Hall Cumulative Mean Density Walking.....	50
Figure 4.21 - PM Peak 2026 Stage E Design Davies Street Ticket Hall Cumulative Mean Density Queuing.....	50
Figure 4.22 - PM Peak 2026 Stage E Design Intermediate Level Cumulative Mean Density Walking .....	51
Figure 4.23 - PM Peak 2026 Stage E Design Intermediate Level Cumulative Mean Density Queuing.....	51
Figure 4.24 - PM Peak 2026 Stage E Design Platform Level Cumulative Mean Density Walking .....	52
Figure 4.25 - PM Peak 2026 Stage E Design Platform Level Cumulative Mean Density Queuing .....	52
Figure 4.26 - PM Peak 2026+28% Stage E Design Hanover Square Ticket Hall Cumulative Mean Density Walking.....	55
Figure 4.27 - PM Peak 2026+28% Stage E Hanover Square Ticket Hall Cumulative Mean Density Queuing.....	55
Figure 4.28 - PM Peak 2026+28% Stage E Design Davies Street Ticket Hall Cumulative Mean Density Walking.....	56
Figure 4.29 - PM Peak 2026+28% Stage E Design Davies Street Ticket Hall Cumulative Mean Density Queuing.....	56
Figure 4.30 - PM Peak 2026+28% Stage E Design Intermediate Level Cumulative Mean Density Walking .....	57
Figure 4.31 - PM Peak 2026+28% Stage E Design Intermediate Level Cumulative Mean Density Queuing.....	57
Figure 4.32 - PM Peak 2026+28% Stage E Design Intermediate Level Cumulative Mean Density Walking .....	58
Figure 4.33 - PM Peak 2026+28% Stage E Design Intermediate Level Cumulative Mean Density Queuing.....	59
Figure 4.34 - PM Peak 2026+28% Stage E Design Platform Level Cumulative Mean Density Walking .....	60

Figure 4.35 - PM Peak 2026+28% Stage E Design Platform Level Cumulative Mean Density Queuing.....	60
Figure 4.36 - PM Peak 2026+28% Stage E Design Intermediate Level Cumulative Mean Density Walking .....	61
Figure 5.1 – PM Peak 2026+7% Intermediate Level Walking Level of Service .....	65
Figure 5.2 – PM Peak 2026+7% Intermediate Level Queuing Level of Service .....	66
Figure 5.3 – PM Peak 2026+14% Intermediate Level Walking Level of Service .....	67
Figure 5.4 – PM Peak 2026+14% Intermediate Level Queuing Level of Service .....	68
Figure 5.5 – PM Peak 2026+21% Intermediate Level Walking Level of Service .....	69
Figure 5.6 – PM Peak 2026+21% Intermediate Level Queuing Level of Service .....	70
Figure 5.7 – PM Peak 2026+7% Platform Level Walking Level of Service.....	73
Figure 5.8 – PM Peak 2026+14% Platform Level Walking Level of Service.....	74
Figure 5.9 – PM Peak 2026+21% Platform Level Walking Level of Service.....	75

**List of Tables**

Table 2.1 – AM Peak 2026 Passenger Demand (07:00-10:00 hrs).....	16
Table 2.2 – PM Peak 2026 Passenger Demand (16:00-19:00 hrs).....	17
Table 2.3 – AM Peak 2026+28% Passenger Demand (07:00-10:00 hrs).....	17
Table 2.4 – PM Peak 2026+28% Passenger Demand (16:00-19:00 hrs).....	18
Table 4.1 – Hanover Square Gate Line Pedestrian Flows per Gate.....	32
Table 4.2 – Davies Street Gate Line Pedestrian Flows per Gate .....	33
Table 4.3 – LU’s SPSG Level of Service Criteria .....	34
Table 4.4 – AM Peak 2026 Pedestrian Density.....	40
Table 4.5 – AM Peak 2026+28% Pedestrian Density .....	47
Table 4.6 – PM Peak 2026 Pedestrian Density.....	53
Table 4.7 – PM Peak 2026+28% Pedestrian Density .....	62



## Executive Summary

### Introduction

This report is the Final C132 Legion Modelling Report and includes the final pedestrian modelling results for all areas of the proposed Bond Street Crossrail station.

Upon appointment C132 inherited the *Employers* SD3 plans and a Legion pedestrian model from Arup. This model and plans were the subject of a due diligence check by C132. Minor discrepancies were found between the model and plans but it was concluded that:

*“there are no significant errors within the model and it is accurately replicating pedestrian movements within the Bond Street Crossrail Station.”*

Design of the ticket hall layouts and platforms progressed and the Stage D layouts were again assessed using the Legion model. It was concluded that:

*“the Stage D design in the 2016+35% scenarios does not highlight any issues within the station and performs within the acceptable guidelines.”*

Two significant events then occurred.

- Design work progressed to Stage D Extra.
- Instruction EAI 019 GEN was received.

EAI 019 GEN increased the passenger flow through both ticket halls and revised the assessment year to 2026+28%. When the revised matrices were combined with the Stage D Extra layouts, it was found that non-compliances occurred. An Impact Study Report was produced in November 2010 which summarised the non-compliant areas as:

- AM and PM 2026+28%
  - Hanover Square Gateline
- PM 2026+28%
  - Area in front of escalators to Intermediate Level/Davies Street
  - Davies Street Gateline
  - Eastbound Platform

Between November 2010 and July 2011 a series of meetings were held to investigate what actions and work were required to overcome the non-compliances. London Underground (LU), Crossrail Limited (CRL) and C132 all attended these meetings that were held in a spirit of co-operation. Details of the meetings and work undertaken are referred to elsewhere in the report.

The most significant changes instructed by Crossrail in the course of the meetings were:

- Use of WAGs by PRMs
- Movement of the train stopping position (east bound)
- Provision of additional gates at the ETH
- Further revisions to the PM matrix, moving passengers from WTH to ETH (instructed in EAI GEN083)
- Reconfiguration of the escalators

## Results

The results presented in this report demonstrate that in both the AM and PM peak models in the 2026 scenario the station complies with Crossrail guidelines. IN the AM 2026 and 2026+28% scenarios there is some walking level of service D that occurs in the westbound platform cross passageway to Davies Street. However due to the underutilisation of the adjoining cross passageway it is believed this would not level of service would not occur with signage to direct pedestrians to use this cross passageway. All other model results in the AM peak 2026+28% model results also comply with CPFR and LU 1-371, however the PM peak 2026+28% levels of density at the Intermediate and platform level do not comply.

Breakpoint modelling therefore was undertaken for the Intermediate and platform level. It was identified that the Intermediate level complies in 2026+21% but not at 2026+28% so the breakpoint lies somewhere between the two.

The mitigation proposed to alleviate this problem of queuing pedestrians at the Intermediate level is to use the fire escape stairs between Intermediate and platform level. Static calculations have been completed and these stairs are able to cope with all the pedestrian demand from the LU tunnel to the Crossrail platforms, with PM peak 2026+28% pedestrian demand.

The platform level break point is at 2026+14% when 6% of the platform experiences non-compliant density levels.

## Model Status

A comprehensive and detailed audit of the model was undertaken by LU in November 2010. The various issues raised have been addressed within the model, but a final summary report of the issues and the actions taken to close them out is required by LU. This is contained within Appendix K.

Various coding parameters were changed within the model since the LU audit of November 2010. However as the model has been developed LU have undertaken spot checks on the changes made and on 20 July 2011 confirmed that the model remains technically correct and acceptable.

Full LU approval to the model will only be granted once the model can be reviewed in conjunction with the complete report for the whole station.

## 1 Introduction

### 1.1.1 Background and History

Prior to C132 undertaking design work for the Bond Street Station (BOS) an SD3 layout had been produced by Arup on behalf of Cross London Rail Links. The Arup Legion pedestrian model files received from Crossrail were:

#### **AM Peak (07:00 – 10:00)**

- Bond St AM 135% V5.lgm
- Bond St AM 135% V5\_Base.res

#### **PM Peak (16:00 - 19:00)**

- Bond St PM 135% V9.lgm
- Bond St PM 135% V9\_Base.res

A due diligence exercise was undertaken by C132 on these models. This found minor inconsistencies between the SD3 drawings and the AutoCAD plans contained within the Legion model. It was however concluded that the model represented the BOS situation accurately enough to be used for modelling as design work progressed.

During May 2010 a Legion modelling report was produced which assessed the Stage D design [C132-WSP-T3-RGN-C125-0002]. This report concluded that;

*“The report presents the result of the Stage D Design compared to the SD3 design and highlights that the Stage D Design in the 2016 +35% scenario does not highlight any issues for pedestrians within the station and performs within acceptable guidelines.”*

Contract instruction EAI019 GEN “Revised Demand Forecasts” was received on 6<sup>th</sup> May 2010. This instruction issued revised pedestrian demand matrices that C132 had to consider and model. An Impact Study Report [C132-WSP-T3-RGN-C125-0005 Rev 2.0] formed the output for this work. EAI 019 GEN, which essentially replaced CPFR Appendix B, and increased the flow through both ticket halls; particularly the WTH. The Impact Study Executive Summary concluded that;

*“Overall the Stage D Extra Design with the new demand matrices in the 2026+28% scenario performs within acceptable levels with the exception of the following areas and scenarios:*

- AM and PM 2026+28% - Hanover Square gateline
- PM 2026+28%
  - Area in front of Escalators to Intermediate Level/ Davies Street
  - Davies Street gateline
  - Eastbound Platform

Between November 2010 and July 2011 C132 worked closely with CRL and LU to resolve the non-compliances that were identified within the Impact Study Report. A series of meetings were held, involving all parties to propose ideas. The purpose of these were to instruct C132 in further work, review the results of further modelling and work as a team to solve the problems.

This involved further revisions by CRL to the matrices which accompanied instruction EAI 019 GEN. Finally on 5<sup>th</sup> July 2011 C132 presented results to CRL and LU which demonstrated compliance with the project standards and requirements. This compliance was however only achieved after the Legion model was coded to permit PRMs to use WAGs at the Eastern Ticket Hall.

The process followed between November 2010 and July 2011, when a solution was found, is documented more fully in Appendix L.

Instruction EAI 086 "Adoption of Revised PM Peak Passenger Matrices" was received by C132 on 18 July 2011. Matrices attached to the instruction clarify that:-

AM Peak Matrix – these remain as per CPFR 5.0 (i.e. those appended to EAI 019 GEN)

PM Peak Matrix – the matrix attached to EAI 086 is to be used

### 1.1.2 LU Audit of Legion Model Files

The Legion model was the subject of an LU audit in November 2010. Audit results are contained in a letter from LU on 9<sup>th</sup> November 2010; with 15 issues being raised. A meeting between LU, C132 and Crossrail on 10<sup>th</sup> November 2010 was held to discuss the issues highlighted in the model audit. Following this meeting a list of actions was completed by LU for C132 to incorporate into the models. The detailed model audit from LU can be found in Appendix K along with the list of actions; however a summary list is detailed below:

- The train arrival profiles in the 2026 AM Peak Model are inaccurate
- Ealing Broadway CRL WB service in 2026+28% models not modelled accurately
- PRM speed profiles are not in accordance with Legion Best Practice Guide
- In 2026 and 2026+28% PM Peak models there is serious impediment to movements observed between 17:50-18:10 in front of carriage 10 on CRL EB platform
- Door widths on CRL trains are inconsistent
- WAG delay not in line with Legion Best Practice Guide
- Lift capacities / associated logic for the 2026+28% models particularly those passengers in the Intermediate Concourse on the Davies Street side of the station.

C132 met with LU on 16<sup>th</sup> November 2010 to go through the changes made as a response to the audit and ensure that LU were content with the coding changes made. At this meeting it was agreed the alterations made to the model since the audit had improved issues. Version 2.0 of the Impact Study was issued on 24<sup>th</sup> November 2010 and this addressed the audit issues outlined above.

Further changes were introduced between November 2010 and July 2011. LU were aware of the changes made within the model over this period and the topic of further audit requirements were discussed in the meetings. LU have decided that a further full audit of the whole model is not required, but spot checks on the changes made were carried out.

C132 issued the Legion model files to LU via CRL during June 2011. On 20<sup>th</sup> July 2011 LU confirmed that:

- Spot checks made on the model by LU demonstrate that it remains technically correct and is acceptable.

- LU will only formally approve the Legion model once the final report for the whole station has been produced and reviewed by LU staff.
- A summary report on the issues raised in the LU audit can be found in Appendix K, although LU also accepts that these have been addressed within the model.

Since July 2011 no further material changes were made to the model. C132 therefore have a Legion model that is technically correct and acceptable to assess the passenger flows at BOS.

### 1.1.3 Purpose of Report

This report forms the supporting evidence that will be referred to in the DOORS system by the C132 Requirements Manager. The purpose of this report is to demonstrate that the Stage E design of the Bond Street Crossrail Station is compliant with the following project standards and requirements.

- LU 1-371 Station Planning
- *“CPFR0804 CRL has developed a series of demand matrices for all stations using TfL’s London –wide demand model. These are indicated in Appendix B (of the CPFR). The matrices indicate the level of demand expected in 2026.*
- *CPFR0806 Crossrail stations shall be designed to provide the relevant Fruin levels of service in accordance with London Underground’s **SPSG** (Ref R.15) modified for Crossrail by the **New Works Standard Baseline** (Ref R.22).*
- *CPFR4291 Station complexes shall be modelled to demonstrate the ability to meet 2026 demand based on a peak 200m x 24tph Crossrail service.*
- *CPFR5545 Crossrail station complexes shall be designed to cope with a 28% uplift in demand from the 2026 forecast (not Canary wharf, which shall be designed to cope with a 10% uplift). This is based on a 200m x 30 tph peak Crossrail service. As a general principle, areas which are dedicated to Crossrail (Platforms, new ticket halls and associated vertical circulation) shall – subject to affirmation – either be sized to reflect 2026 demand + 28% or shall have passive provision which would enable this demand to be met without the station having to be closed (or operating with severely degraded capacity for a protracted period).*

*If the modelling indicates that elements of the station cannot meet this level of demand, work shall be done:*

- a) To identify which elements become unacceptably overcrowded and the approximate date when this occurs;*
- b) Whether there are any reasonable station control measures which could mitigate the impact of this overcrowding which should be reflected in CRL’s Resilience Plan [Ref R2.1];*

- c) To identify what infrastructure based mitigation may be possible having regard for the value for money offered by such mitigation.

*CRL shall seek affirmation from Sponsors of proposals which cannot meet 28% uplift from 2026 demand but for which other constraints (e.g. limited ability of LU to handle growth) justify a lower capability.*

- CPFR4294 *The stations shall be modelled using the Legion Studio passenger modelling software.”*

Commentary on the individual compliance issues is as follows.

Fruin levels are demonstrated throughout the report by means of Cumulative Mean Density maps which are cross referenced to the relevant year, peak hour, percentage growth and time.

Matrices used by C132 are those nominated by CPFR0806 (EAI 019 GEN) for the AM peak three hours and revised matrices issued in conjunction with EAI 086 – Adoption of Revised PM peak passenger matrices, issued 18 July 2011, for the PM peak three hours.

Train frequency specified in CPFR4291 is inherent in the Legion model and stated in the cover sheets contained in Appendices A-D.

The requirement for the station to fully comply with the 2026+28%. This has not been achievable. C132 have therefore followed the process detailed in CPFR5545 to establish which elements cannot achieve the +28% requirement and in what year they exceed the nominated Fruin Level. Details of how this has been achieved are explained in Chapter 5 of this report.

C132 confirm that Legion Studio passenger modelling software has been used throughout the contract.

This report has been produced in accordance with “Note on Modelling Outputs”, which provides guidance to Crossrail FDCs on the outputs required.

#### 1.1.4 Model Scenarios

Two scenarios were developed for both the AM and PM peak models. These are summarised below:

- AM and PM Stage E Design (2026 with perturbed timetable (one cancelled train in the peak 15 minutes))
  - These models use the latest Bond Street Station design that C132 has developed using Stage E design drawings with the 2026 pedestrian demand for Bond Street Station.
- AM and PM Stage E Design (2026+28% with perturbed timetable (one cancelled train in the peak 15 minutes))
  - These models use the latest Bond Street Station design that C132 has developed using Stage E design drawings with the 2026 pedestrian demand and an uplift of 28% for Bond Street Station.

#### 1.1.5 Model Specification

The Stage E Design models incorporate a 10 car, 200 metre train. The dwell times are specified to be 45 seconds of which 35 seconds is effective door open time for 2026 and 30 seconds with 22 seconds effective door open time for 2026+28%, as per CPFR1107. Appendices A to D contain the cover sheets for the model scenarios and these comprise the full model specifications.

#### 1.1.6 Modelling Standards

The modelling analysis adheres to the following standards:

- Railway Safety Principles and Guidance, Part 2, Section B, Guidance on stations
- LU 1-371, Issue A3
- The Crossrail Programme Functional Requirements (CPFR).
- Crossrail Modelling Procedures
- Legion modelling guidance for headroom in CRL circular passages received 8<sup>th</sup> September 2010
- Guidance on Legion model outputs required received 20<sup>th</sup> September 2010
- LU Best Practice Guide
- Crossrail guidance on the walking width on headroom in circular tunnels
- Crossrail Peaking Factors Central Station, CRL1-XRL-T1-RGN-CRG02-00001.

## 2 Data Input

### 2.1.1 Introduction

This chapter presents the 2026 and 2026+28% pedestrian demand used in the Stage E design models. Only passengers passing through the Crossrail ticket halls and platforms are shown in the matrices.

### 2.1.2 Stage E design models: 2026 pedestrian demand

The 2026 pedestrian demand used in the Stage E design models are shown in Table 2.1 and Table 2.2. This data was supplied by Cross London Rail Links (CLRL). It is important to note that the C132 scope does not extend to the production or interpretation of matrices. The AM matrix is as instructed in EAI GEN019 and the PM peak matrix provided to C132 on 21<sup>st</sup> April 2011 and in EAI GEN086.

**Table 2.1 – AM Peak 2026 Passenger Demand (07:00-10:00 hrs)**

	BOND ST DAVIES SE	BOND ST HANOVER SQ SE	BOND STREET CENTRAL (EB)	BOND STREET CENTRAL (WB)	BOND STREET JUBILEE (NB)	BOND STREET JUBILEE (SB)	BOND ST CROSSRAIL (EB)	BOND ST CROSSRAIL (WB)	TOTAL
BOND ST DAVIES ST SE							350	150	500
BOND ST HANOVER SQ SE							850	750	1600
BOND STREET CENTRAL (EB)							500	50	550
BOND STREET CENTRAL (WB)							0	200	200
BOND STREET JUBILEE (NB)							0	800	800
BOND STREET JUBILEE (SB)							1150	900	2050
BOND ST CROSSRAIL (EB)	800	3850	150	0	100	900	-	-	5800
BOND ST CROSSRAIL (WB)	5050	4650	0	1300	700	0	-	-	11700
<b>TOTAL</b>	<b>5850</b>	<b>8500</b>	<b>150</b>	<b>1300</b>	<b>800</b>	<b>900</b>	<b>2850</b>	<b>2850</b>	<b>23200</b>



**Table 2.2 – PM Peak 2026 Passenger Demand (16:00-19:00 hrs)**

	BOND ST DAVIES SE	BOND ST HANOVER SQ SE	BOND STREET CENTRAL (EB)	BOND STREET CENTRAL (WB)	BOND STREET JUBILEE (NB)	BOND STREET JUBILEE (SB)	BOND ST CROSSRAIL (EB)	BOND ST CROSSRAIL (WB)	TOTAL
BOND ST DAVIES ST SE							6550	1300	7850
BOND ST HANOVER SQ SE							5650	4600	10250
BOND STREET CENTRAL (EB)							1200	0	1200
BOND STREET CENTRAL (WB)							0	150	150
BOND STREET JUBILEE (NB)							0	800	800
BOND STREET JUBILEE (SB)							600	100	700
BOND ST CROSSRAIL (EB)	1100	4150	150	50	850	750	0	0	7050
BOND ST CROSSRAIL (WB)	3550	3550	0	450	1050	0	0	0	8600
<b>TOTAL</b>	<b>4650</b>	<b>7700</b>	<b>150</b>	<b>500</b>	<b>1900</b>	<b>750</b>	<b>14000</b>	<b>6950</b>	<b>36600</b>

### 2.1.3 Stage E design models: 2026+28% pedestrian demand

The 2026+28% pedestrian demand used in the Stage E design models are shown in Table 2.3 and Table 2.4. This is a direct uplift of 28% from the 2026 matrices as shown in Table 2.1 and Table 2.2.

**Table 2.3 – AM Peak 2026+28% Passenger Demand (07:00-10:00 hrs)**

	BOND ST DAVIES SE	BOND ST HANOVER SQ SE	BOND STREET CENTRAL (EB)	BOND STREET CENTRAL (WB)	BOND STREET JUBILEE (NB)	BOND STREET JUBILEE (SB)	BOND ST CROSSRAIL (EB)	BOND ST CROSSRAIL (WB)	TOTAL
BOND ST DAVIES ST SE							448	192	640
BOND ST HANOVER SQ SE							1088	960	2048
BOND STREET CENTRAL (EB)							640	64	704
BOND STREET CENTRAL (WB)							0	256	256
BOND STREET JUBILEE (NB)							0	1024	1024
BOND STREET JUBILEE (SB)							1472	1152	2624
BOND ST CROSSRAIL (EB)	1024	4928	192	0	128	1152			7424
BOND ST CROSSRAIL (WB)	6464	5952	0	1664	896	0			14976
<b>TOTAL</b>	<b>7488</b>	<b>10880</b>	<b>192</b>	<b>1664</b>	<b>1024</b>	<b>1152</b>	<b>3648</b>	<b>3648</b>	<b>29696</b>

**Table 2.4 – PM Peak 2026+28% Passenger Demand (16:00-19:00 hrs)**

	BOND ST DAVIES SE	BOND ST HANOVER SQ SE	BOND STREET CENTRAL (EB)	BOND STREET CENTRAL (WB)	BOND STREET JUBILEE (NB)	BOND STREET JUBILEE (SB)	BOND ST CROSSRAIL (EB)	BOND ST CROSSRAIL (WB)	TOTAL
BOND ST DAVIES ST SE	0	0	0	0	0	0	8384	1664	10048
BOND ST HANOVER SQ SE	0	0	0	0	0	0	7232	5888	13120
BOND STREET CENTRAL (EB)	0	0	0	0	0	0	1536	0	1536
BOND STREET CENTRAL (WB)	0	0	0	0	0	0	0	192	192
BOND STREET JUBILEE (NB)	0	0	0	0	0	0	0	1024	1024
BOND STREET JUBILEE (SB)	0	0	0	0	0	0	768	128	896
BOND ST CROSSRAIL (EB)	1408	5312	192	64	1088	960	0	0	9024
BOND ST CROSSRAIL (WB)	4544	4544	0	576	1344	0	0	0	11008
<b>TOTAL</b>	<b>5952</b>	<b>9856</b>	<b>192</b>	<b>640</b>	<b>2432</b>	<b>960</b>	<b>17920</b>	<b>8896</b>	<b>46848</b>

#### 2.1.4 Peak Time Periods

During the AM and PM peak 3 hour time periods the peak 15 minute time period occurs at the time of the cancelled train, which is between 8:45-9:00 in the AM peak and 17:45-18:00 in the PM peak provided to us by Crossrail. The modelling results contained within the report are focussed on these time periods, with all peak hour 15 minute maps presented in Appendices E to H. Peaking conversion factors from CRL report were used throughout the C132 work.

### 3 Station Layout

#### 3.1.1 Introduction

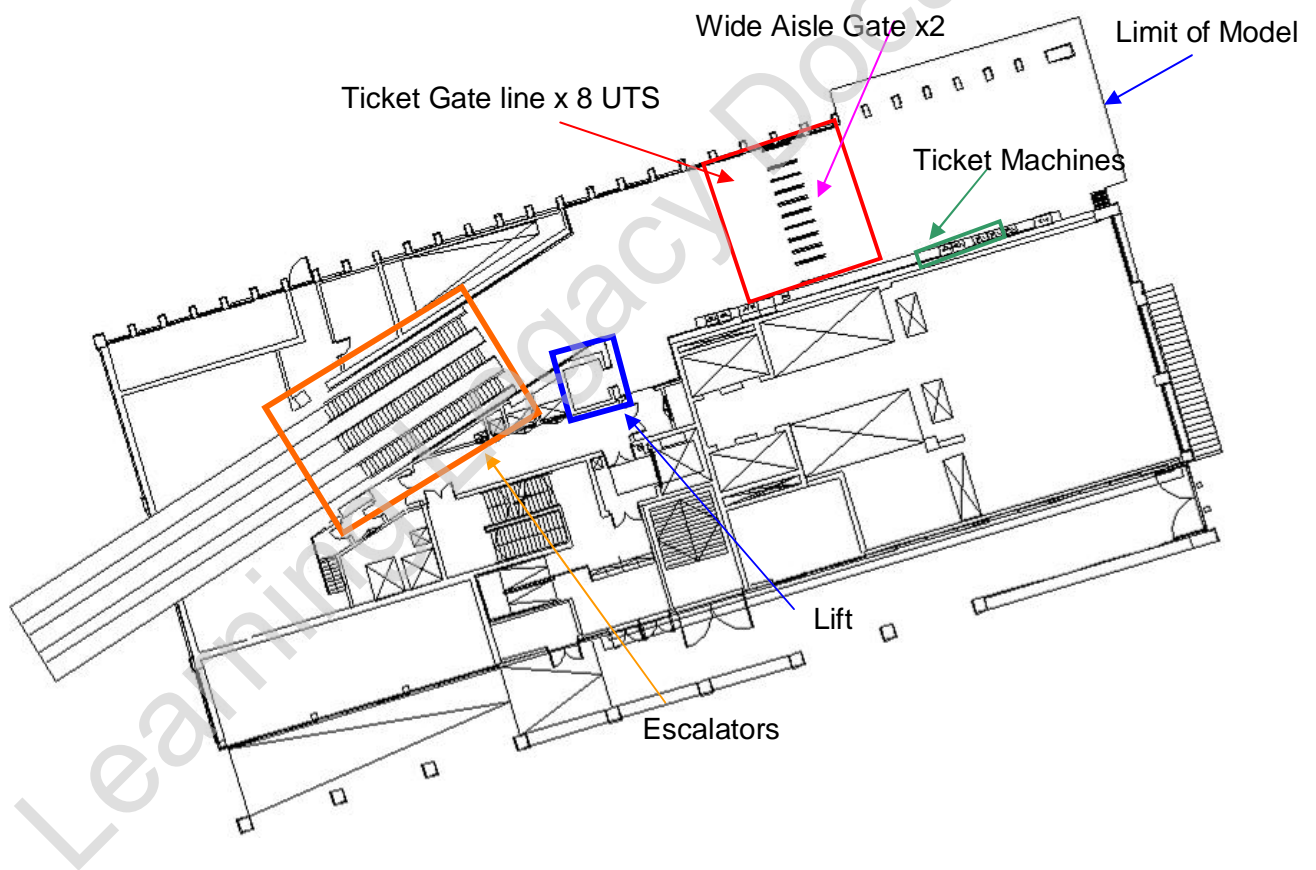
This chapter of the report presents the Stage E station layout. All layout drawings used within the Legion model are presented in this chapter. This chapter also outlines the circular passageway widths adopted within the model. Appendices I and J also contain the layout drawings.

#### Hanover Square Ticket Hall

The Stage E design layout for Hanover Square ticket hall is shown in

Figure 3.1, illustrates the location of the escalators, lifts, ticket machines and the ticket gate line. The ticket barrier configuration is 2 Wide Aisle Gates (WAG) and 8 Underground Ticketing System (UTS) gates.

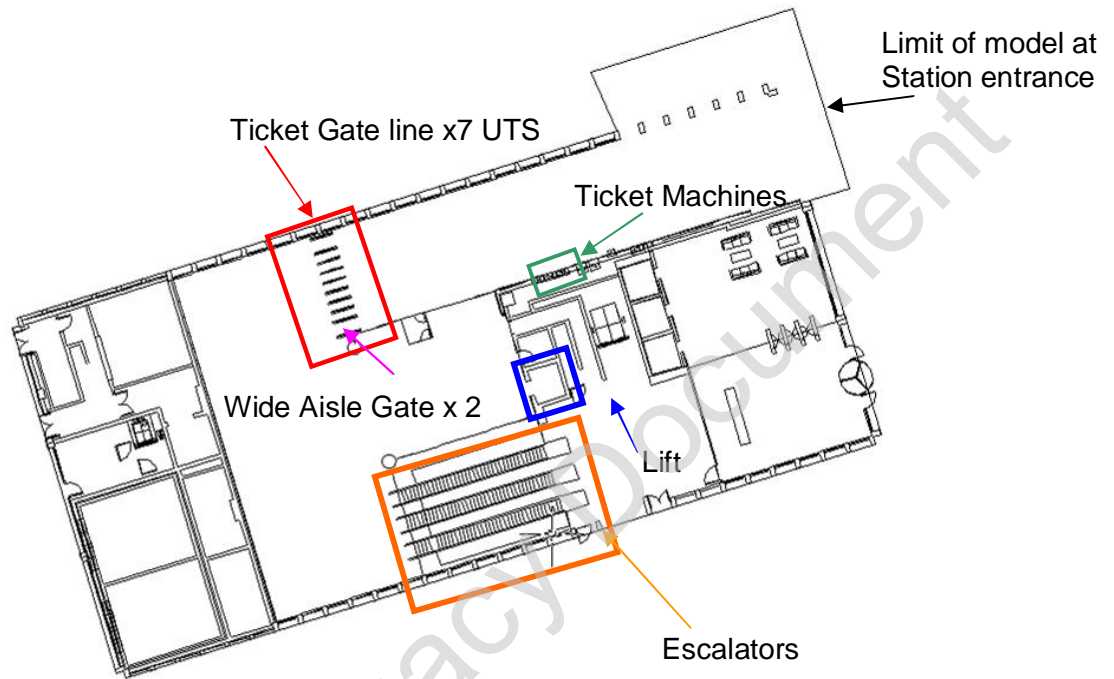
Figure 3.1 – Hanover Square Ticket Hall Stage E Design Layout



### Davies Street Ticket Hall

The Stage E design layout for the WTH is shown in Figure 3.2 which illustrates the location of the escalators, lifts, ticket machines and the ticket gate line. The ticket barrier configuration is 2 Wide Aisle Gates (WAG) and 7 Underground Ticketing System (UTS) gates.

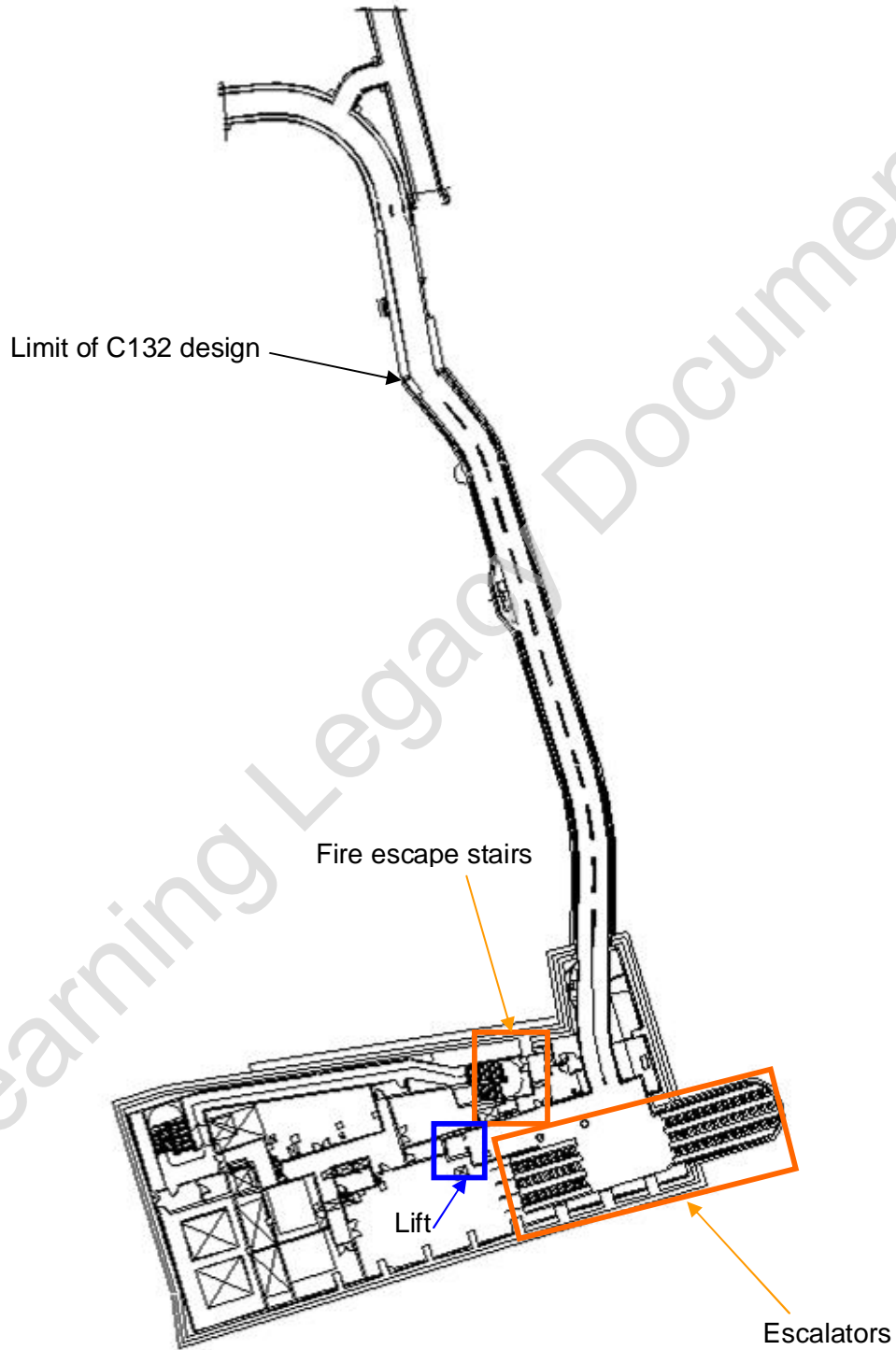
Figure 3.2 – Davies Street Ticket Hall Stage E Design Layout



### Intermediate Level

The escalator and lift alignment at the WTH Intermediate Level is shown in Figure 3.3. The full length of the LU passageway is incorporated into the Stage E model.

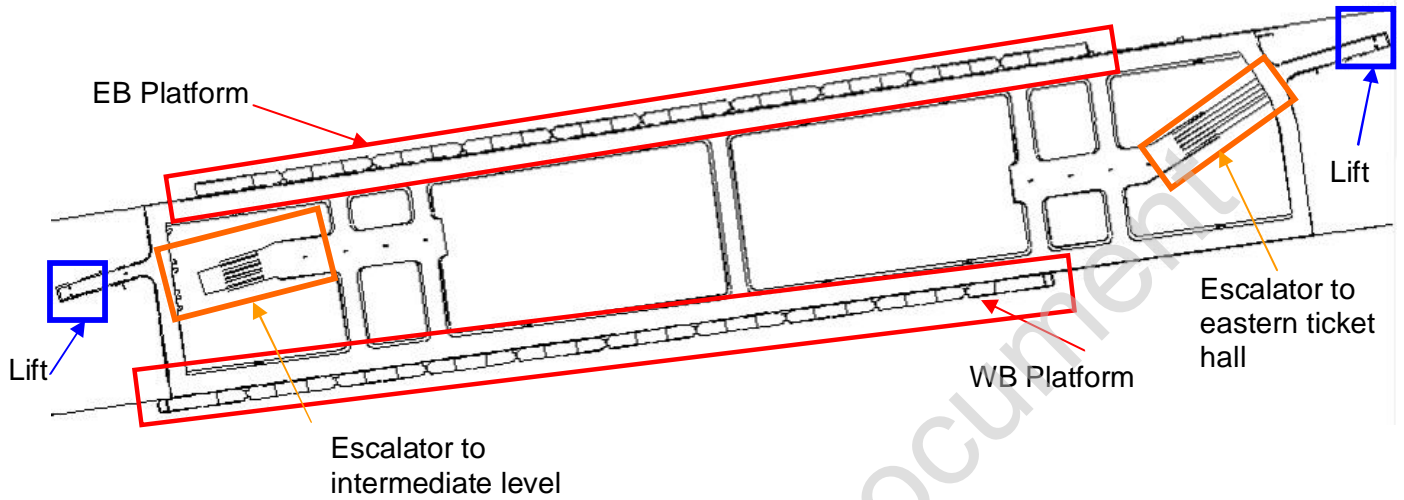
**Figure 3.3 – Intermediate Level Stage E Design Layout**



### Platform Level

The Stage E Design models incorporate a 10 car, 200 metre train as illustrated in Figure 3.4.

**Figure 3.4 – Platform Level Stage E Design Layout**



It is important to note that the escalators in both the AM and PM peak models are configured with 2 going up and 1 down in both the western and eastern ticket hall.

### 3.1.2 Corridor Widths

Following an email communication from Crossrail's pedestrian modelling team on 8<sup>th</sup> September 2010 the passageway widths for circular passages used within the Legion model are now outlined in this section of the report.

The widths of the passageways within the Bond Street Legion model is shown in Figure 3.5, the width is based on a 2.4m height. Figure 3.6 to Figure 3.10 illustrate the circular passageways within Bond Street Station.

Figure 3.5 – Cross Passageway

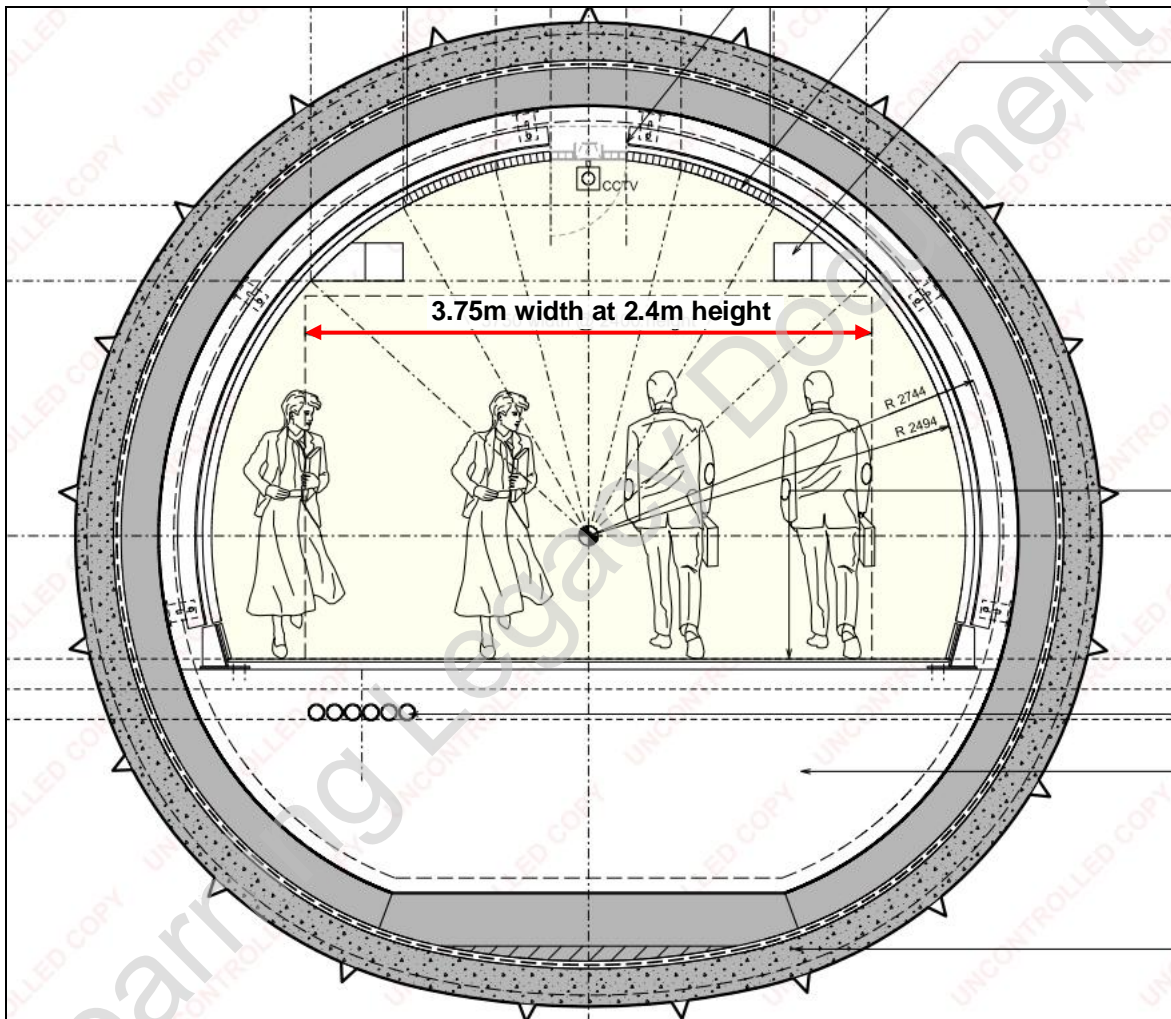


Figure 3.6 – LU Passageway Effective Width

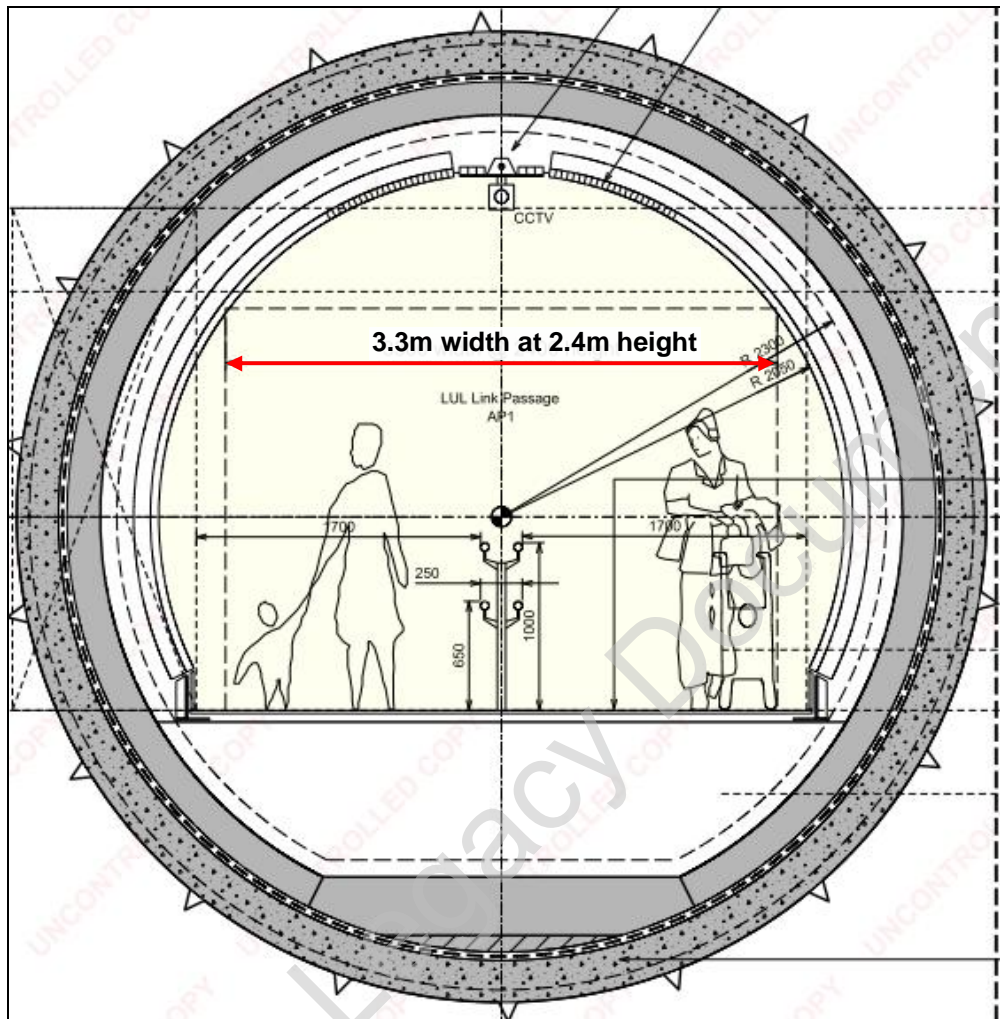




Figure 3.7 – Western Passageway to Lifts

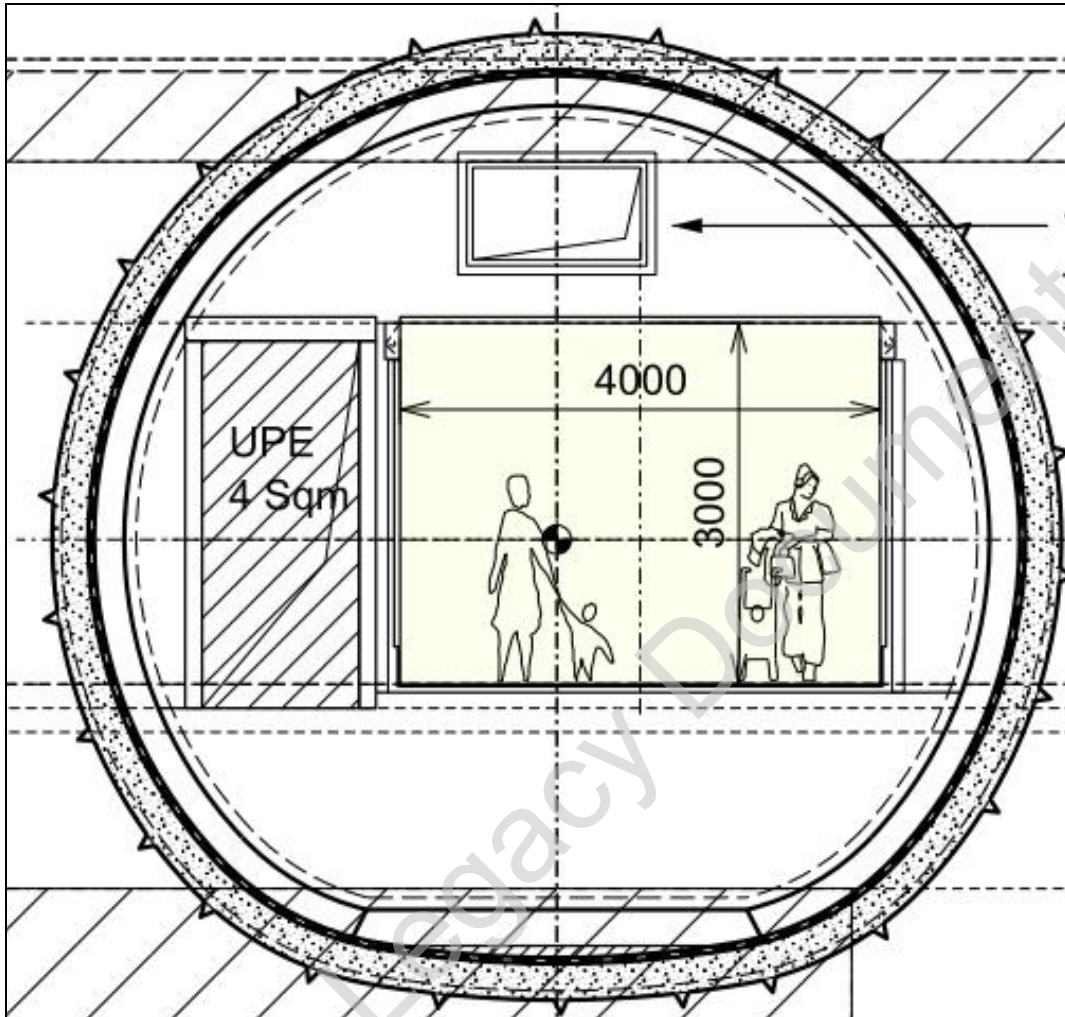


Figure 3.8 – Eastern Passageway to Lifts

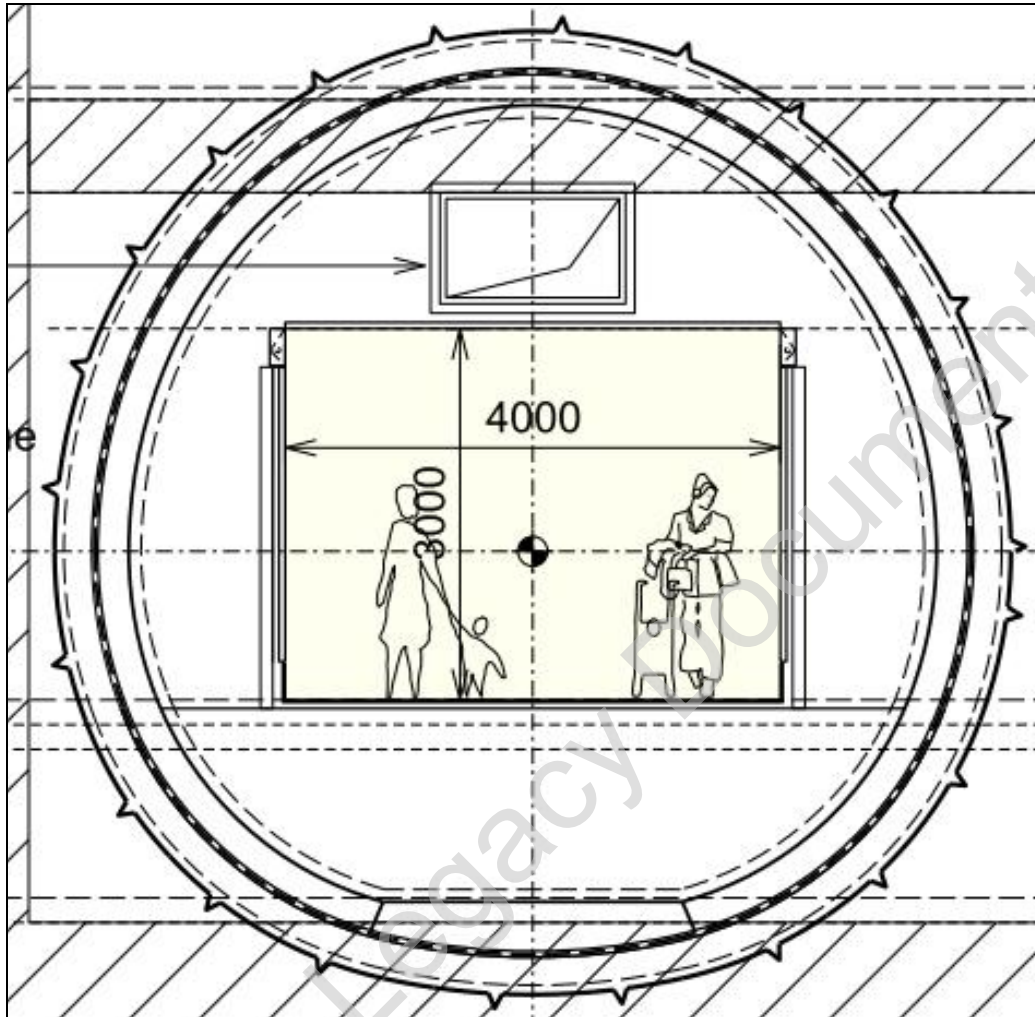


Figure 3.9 – Lower Concourse Passageway

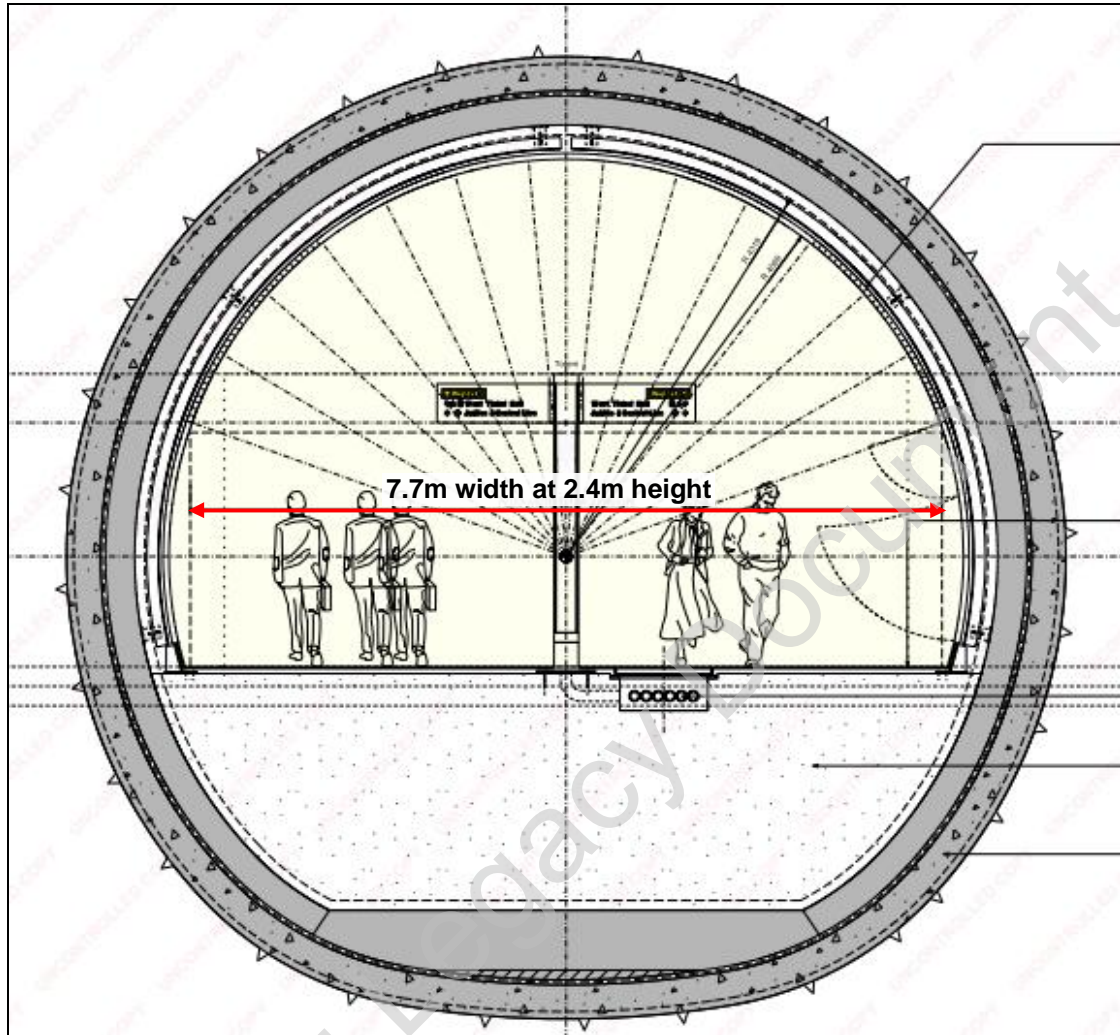
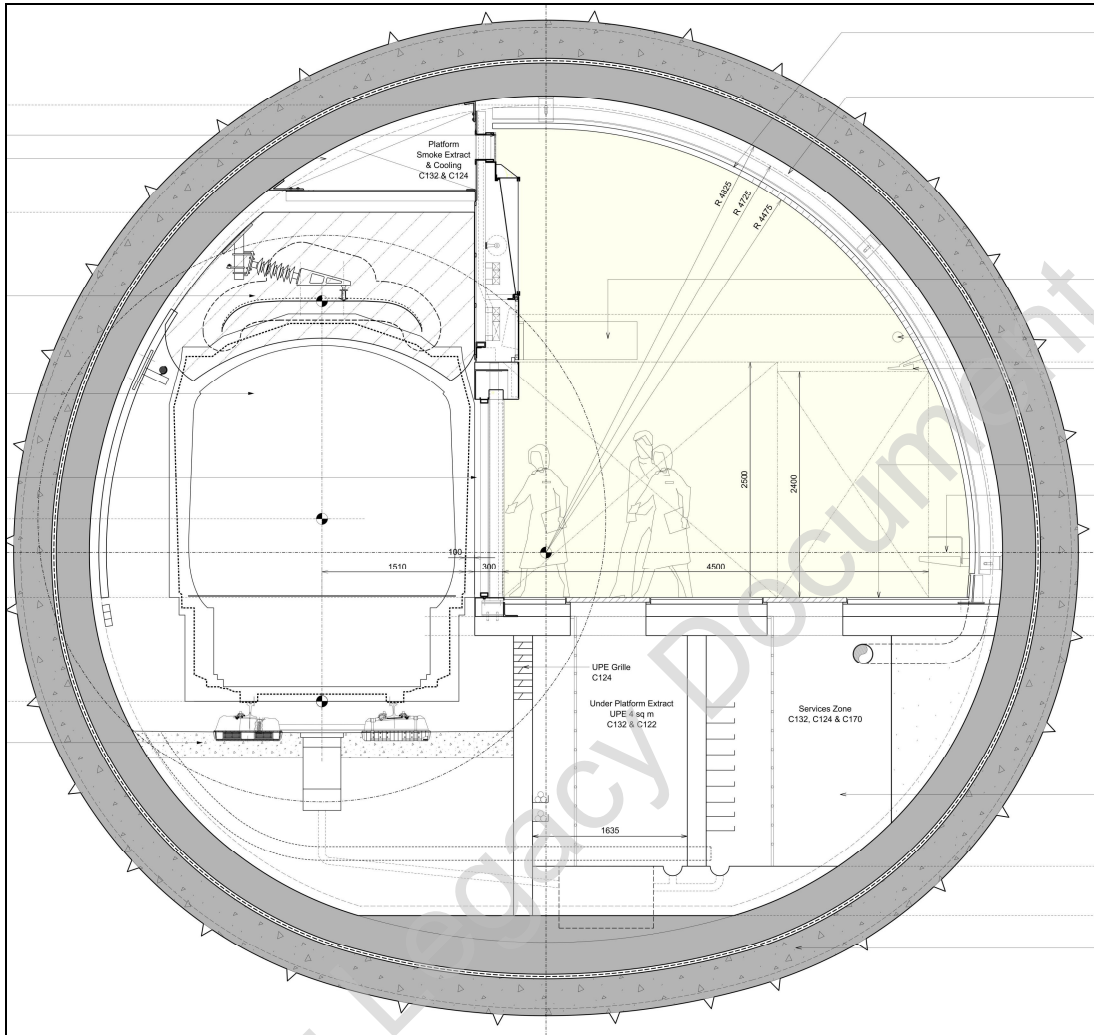


Figure 3.10 – Platform



## 4 Legion Modelling

### 4.1.1 Introduction

This chapter summarises the model results of the 2026 and 2026+28% Stage E Design for the Bond Street Station. The station comprises:

- The Western Ticket Hall including the station entrance at Davies Street as well as the intermediate level which provides a connection with the London Underground;
- The Eastern Ticket Hall i.e. station entrance at Hanover Square; and
- The eastbound and westbound platforms including cross-passages and lower concourses.

### 4.1.2 Level of Service

Professor John Fruin in his book John J Fruin – Pedestrian Planning & Design (1971) defined a series of Levels of Service (LoS) bands from Level A (free space) through to Level F (extreme crowding) based upon densities for walkways, such as ticket halls and corridors, and also for queues such as ticket gates, escalators and ticket queues.

It is important to note that separate Fruin levels are applied for walking and for queuing. This is to reflect the different crowding densities pedestrians are prepared to tolerate under different circumstances. When queuing, pedestrians' tolerance of reduced space tends to be higher than that for walking. Therefore, areas such as ticket barriers and the platform edge are measured using the Fruin LoS for Queuing, whilst all other areas are measured using the Fruin LoS for Walking.

#### 4.1.3 Definition of Fruin LoS for Walking

The definitions for each Fruin LoS for Walking is shown below.

##### Fruin LoS A - up to 0.31 people/m<sup>2</sup>

Sufficient area is available for pedestrians to freely choose their walk speed, pass by slower pedestrians and avoid all conflict with others. Areas designed to this standard would include public open spaces.

##### Fruin LoS B - up to 0.43 people/m<sup>2</sup>

Sufficient area is available for pedestrians to choose their normal walking speed and pass by slower pedestrians in a primarily one directional flow. Where reverse direction exists minor conflicts will occur. Designs consistent with this LoS would include buildings in which recurrent, but not severe, peaks are likely to occur.

##### Fruin LoS C - up to 0.72 people/m<sup>2</sup>

Freedom to select walk speed and freely pass other pedestrians becomes restricted. There is a high probability of conflicts where reverse flows exist. Designs consistent with this LoS would represent reasonably fluid flow, but considerable friction and interaction between pedestrians is likely to occur. Examples of this type of design would be heavily used transport terminals and public buildings.

##### Fruin LoS D - up to 1.08 people/m<sup>2</sup>

The majority of pedestrians would have their normal walking speed restricted and reduced, due to difficulties in passing by slow moving pedestrians and avoiding conflicts. In reverse flow scenarios pedestrians would experience multiple conflicts. Designs of this nature would represent the most crowded public areas, where it is necessary to always alter walking stride and direction to maintain reasonable progress forward. There is a probability of intermittently reaching critical density causing momentary stoppages of flow.

##### Fruin LoS E - up to 2.17 people/m<sup>2</sup>

Virtually all pedestrians would have their normal walking speeds restricted requiring frequent adjustments of gait. At the lower end of the range forward progress would only be made by shuffling. Reverse flow would be very difficult. This design range should only be employed for short peaks in the most crowded areas. Examples of where this could occur are at sports stadiums and rail facilities where there maybe a large but short term exiting of passengers from a train.

##### Fruin LoS F - greater than 2.37 people/m<sup>2</sup>

All pedestrian walking speeds are extremely restricted and forward progress can only be made by shuffling. Reverse flow is almost impossible. There would be frequent unavoidable contact with other pedestrians. This LoS is representative of a complete breakdown in pedestrian flow.

#### 4.1.4 Definition of Fruin LoS for Queuing

The definitions for each Fruin LoS for Queuing is shown below.

##### Fruin LoS A – Free Circulation Zone - up to 0.83 people/m<sup>2</sup>

Space is provided for standing and free circulation through the queuing area without disturbing others. Applications would include high quality designed passenger concourse areas such as shopping/retail centre and airport lounges.

##### Fruin LoS B – Restricted Circulation Zone - up to 1.08 people/m<sup>2</sup>

Similar to LoS A, space is provided for standing and restricted circulation through the queue without disturbing others. Applications would include rail station platforms and passenger concourse areas such as shopping/retail centre and airport lounges.

##### Fruin LoS C – Personal Comfort Zone - up to 1.54 people/m<sup>2</sup>

Space is provided for standing and restricted circulation through the queuing area by disturbing others. It is within the range of personal comfort. Applications would include ordered-queue ticket selling areas.

##### Fruin LoS D – No-Touch Zone - up to 3.59 people/m<sup>2</sup>

Space is provided for standing without personal contact with others, but circulation through the queuing area is severely restricted. Applications would include lifts and holding areas at crosswalks. This level of occupancy is not recommended for long term periods of waiting.

##### Fruin LoS E – Touch Zone - up to 5.38 people/m<sup>2</sup>

Space is provided for standing but personal contact with others is unavoidable. Circulation within the queuing area is not possible. This level of occupancy can only be sustained for short periods of time without physical and psychological discomfort. The only recommended application would be for lifts.

##### Fruin LoS F – The Body Ellipse - greater than 10 people/m<sup>2</sup>

Space is approximately equivalent to the standing area of the human body. Standing is possible, but close unavoidable contact with the surrounding standees causes physical and psychological discomfort. No movement is possible and in large crowds the potential for panic exists.

#### 4.1.5 Ticket Gateline

To calculate the ticket gateline configuration used within the Legion model, static calculations were completed using LU 1-371. This prescribes the ticket gate configuration to be coded into the Legion model. LU 1-371 provides guidance on how to calculate the required number of ticket gates at a station. The formulae taken from LU 1-371, in Figure 4.1 was used to calculate the number of ticket gates required and therefore the number of ticket gates assumed in each direction within the Legion model. This was completed for 2026 and 2026+28% pedestrian demand scenarios. It is important to note that according to the guidance the first and last part of this equation has been used for boarding and alighting passengers, this is because the total alighting load is contained within the matrices provided.

**Figure 4.1 – Formula for Calculating the Number of Ticket Gates (LU 1-371)**

Thus, the total number of gates =

$$\text{round up } \left\{ \frac{5 \text{ min. entry flow}}{25 \times 5} \right\} + \text{round up } \left\{ \frac{\text{total alighting load}}{25 \times 2} \right\} + X$$

Where X = 1

It is important to note that calculations within this section consider the number of UTS ticket gates for use by all persons. The two Wide Aisle Gates (WAGs) at each ticket gateline are for use for persons with reduced mobility (PRM's) only and therefore excluded from the calculations.

#### Hanover Square

Table 4.1 presents the calculations of the number of ticket gates (excluding WAGs) required according to the formulae in LU 1-371 shown in Figure 4.1. It shows the required and proposed direction of ticket gates for Stage E design in the AM and PM peak period for the 2026 and 2026+28% scenarios.

**Table 4.1 – Hanover Square Gate Line Pedestrian Flows per Gate**

Hanover Square	2026				2026+28%			
	AM		PM		AM		PM	
	IN	OUT	IN	OUT	IN	OUT	IN	OUT
Peak period (3 hrs)	1600	8500	10250	7700	2048	10880	13120	9856
Peak 15 minutes	203	1079	1093	821	260	1381	1399	1051
Peak 5 minutes	81	431	437	328	104	552	559	420
Gates Required (25 passengers per gate per minute)	0.6	3.5	3.5	2.6	0.8	4.4	4.5	3.4
Number of UTS Ticket Gates Required (LUL 1-371)	6.0		8.0		7.0		10.0	
Ticket Gates coded in Legion Model	1	7	3	5	1	7	3	5

It is important to note that using the LU 1-371 formulae, in the 2026+28% scenario during the PM peak at Hanover Square, 10 ticket gates (excluding WAG's) are required. Following modelling work in document number C132-WSP-T3-RGN-C125-50004 it was agreed with CRL and LU that at Hanover Square Non-PRM's use the WAGs to increase the number of ticket gates available to Non-PRM's to 10.



## Davies Street

Similarly for the Davies Street ticket hall, the pedestrian flows were examined to determine the suitable gate line configuration.

Table 4.2 presents the calculations of the number of ticket gates (excluding WAG's) required according to the formulae in LU SPG shown in Figure 4.1. It shows the required and proposed direction of ticket gates for Stage E design in the AM and PM peak period for both 2026 and 2026+28% scenarios. The LU SPG guidance was used to calculate the number of ticket gates required which was used to set the direction of the ticket gates within the Legion model.

**Table 4.2 – Davies Street Gate Line Pedestrian Flows per Gate**

Davies Street	2026				2026+28%			
	AM		PM		AM		PM	
	IN	OUT	IN	OUT	IN	OUT	IN	OUT
Peak period (3 hrs)	500	5850	7850	4650	640	7488	10048	5952
Peak 15 minutes	63	742	837	496	81	950	1071	634
Peak 5 minutes	25	297	335	198	32	380	428	254
Gates Required (25 passengers per gate per minute)	0.2	2.4	2.7	1.6	0.3	3.0	3.4	2.0
Number of UTS Ticket Gates Required (LUL 1-371)	5.0		6.0		6.0		8.0	
Ticket Gates coded in Legion Model	1	6	4	3	1	6	4	3

The Stage E design provides seven ticket gates plus 2 WAGs which is adequate according to LU 1-371 for the pedestrian demand in the 2026 and 2026+28% scenarios.

#### 4.1.6 Acceptance Criteria for Legion Modelling

CRL and LU guidelines were adopted for the presentation of results.

Acceptance criteria from LU 1-371 were applied; these are shown in Table 4.3.

**Table 4.3 – LU's SPSG Level of Service Criteria**

Station Area	Normal Operation LoS	Quantitative Measure
Ticket Hall/ Open Concourses	Queuing LoS B	1.0m <sup>2</sup> per person
Queuing for Ticket Hall facilities	Queuing LoS C	0.8m <sup>2</sup> per person
Passageways:		
One way	Walkway LoS D	50 passengers / minute/ metre width
Two way	Walkway LoS C	40 passengers / minute/ metre width
Stairs		
One way	Stairway LoS D	35 passengers / minute/ metre width
Two way	Stairway LoS C	28 passengers / minute/ metre width
Escalators*		100 passengers/ minute/ metre width
Platforms	Queuing LoS C Walkway LoS C	1.54 person per sq m 0.72 person per sq m

\*It should be noted that a Fruin scale to assess LoS on escalators does not exist. Instead, escalator performance is assessed using numerical flow rates. The LU guideline for Normal Operation conditions for escalators is 100 passengers per minute per metre width.

As Table 4.3 indicates the density on escalators is measured using the quantitative measure of passengers per minute per metre width. To calculate this, the formula below was used.

$$\text{Pedestrians/Minute/Metre} = \frac{\text{Pedestrians per minute}}{\text{Effective width of escalators in metres}}$$

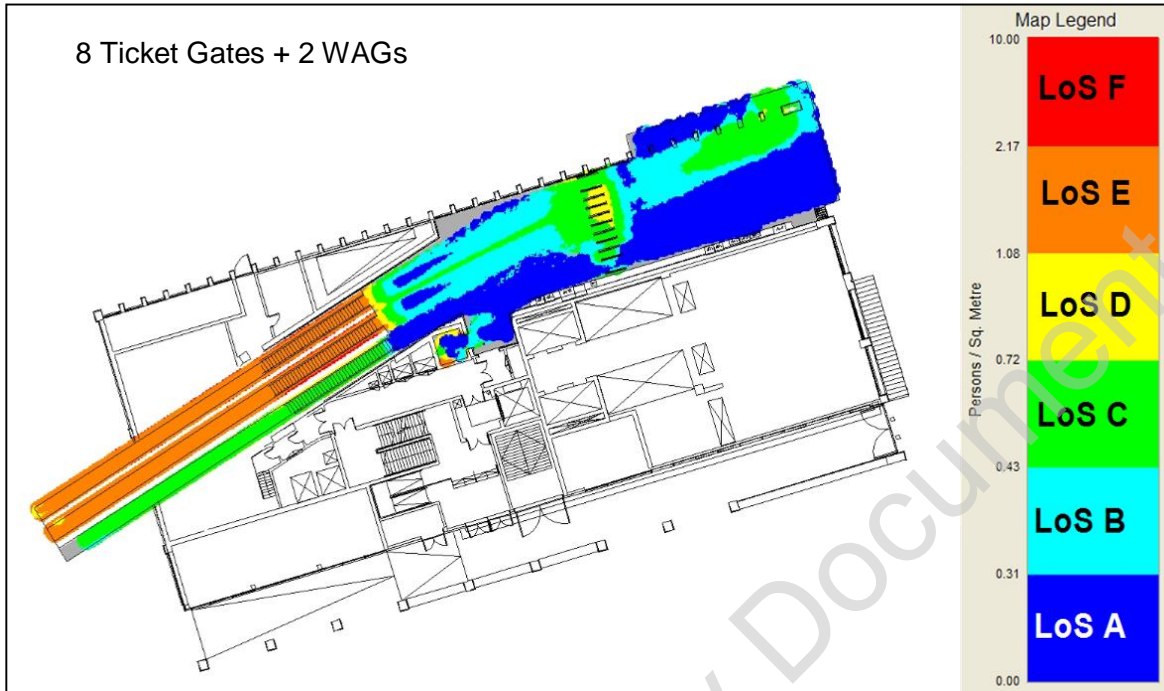
#### 4.1.7 AM Peak 2026 Mean Density Maps

The AM peak 2026 Stage E Design Cumulative Mean Density (CMD) plots for the peak 15 minutes (08:45-9:00) are presented in this chapter. The Cumulative High Density (CHD) and CMD maps for the 2026 AM peak hours in 15 minute segments can be found in Appendix E.

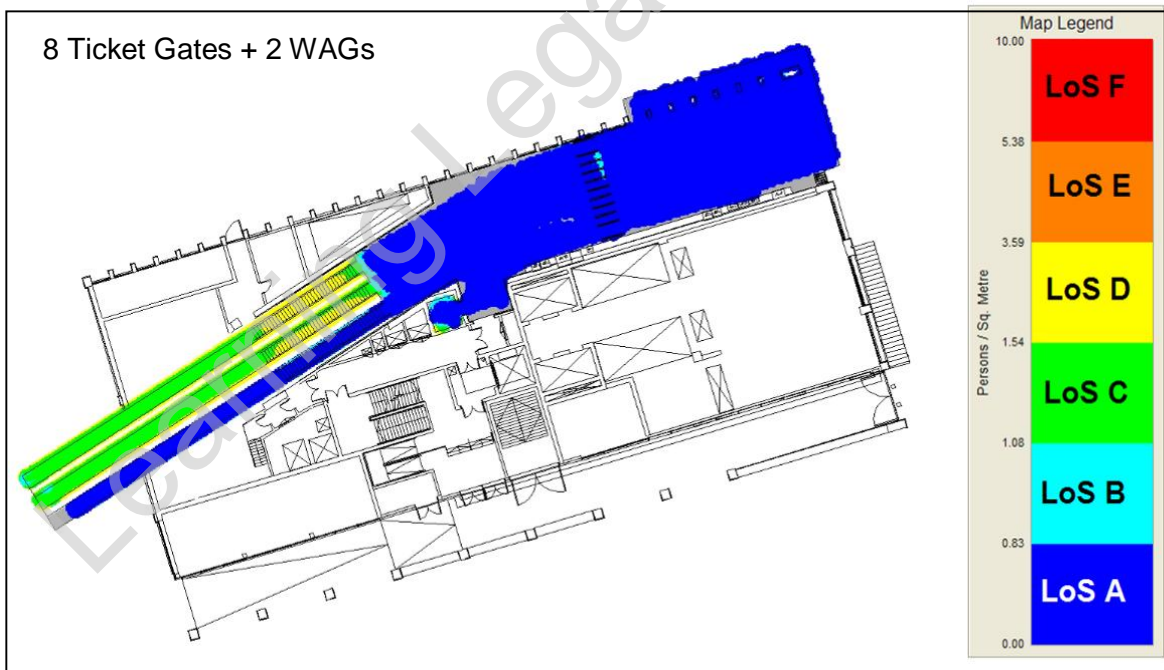
##### Hanover Square Ticket Hall

Figure 4.2 shows the cumulative mean density walking maps of the Hanover Square ticket hall for the 2026 scenario during the AM peak hour. Similarly, Figure 4.3 shows the cumulative mean density maps for queuing during the AM peak hour.

**Figure 4.2 - AM Peak 2026 Stage E Design Hanover Square Ticket Hall  
 Cumulative Mean Density Walking**



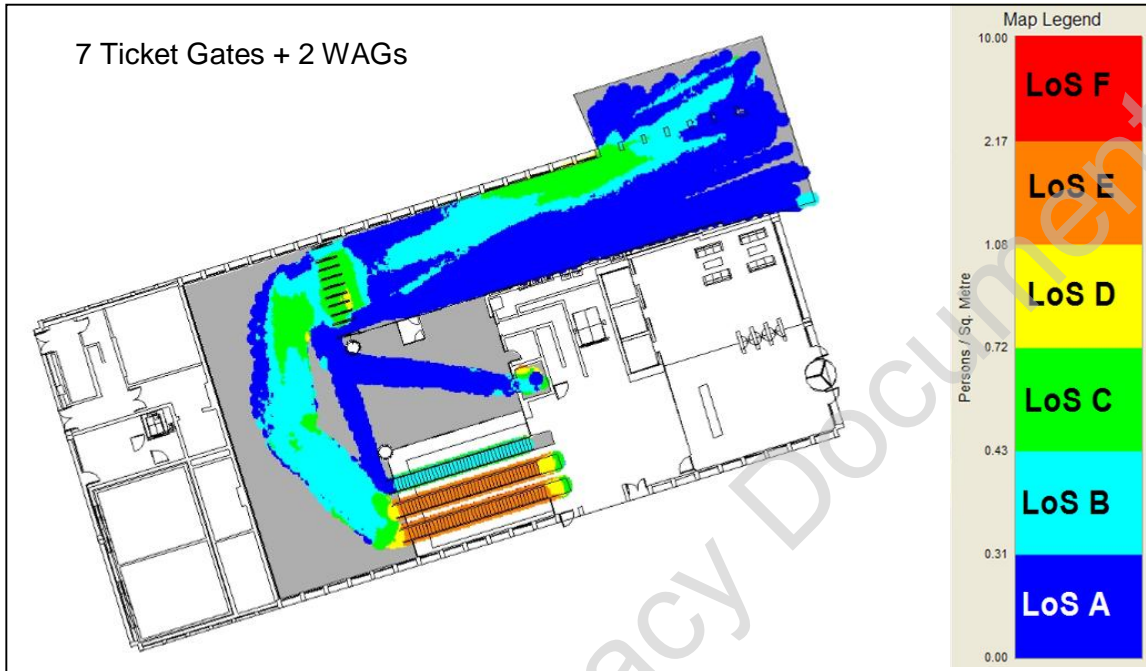
**Figure 4.3 - AM Peak 2026 Stage E Hanover Square Ticket Hall  
 Cumulative Mean Density Queuing**



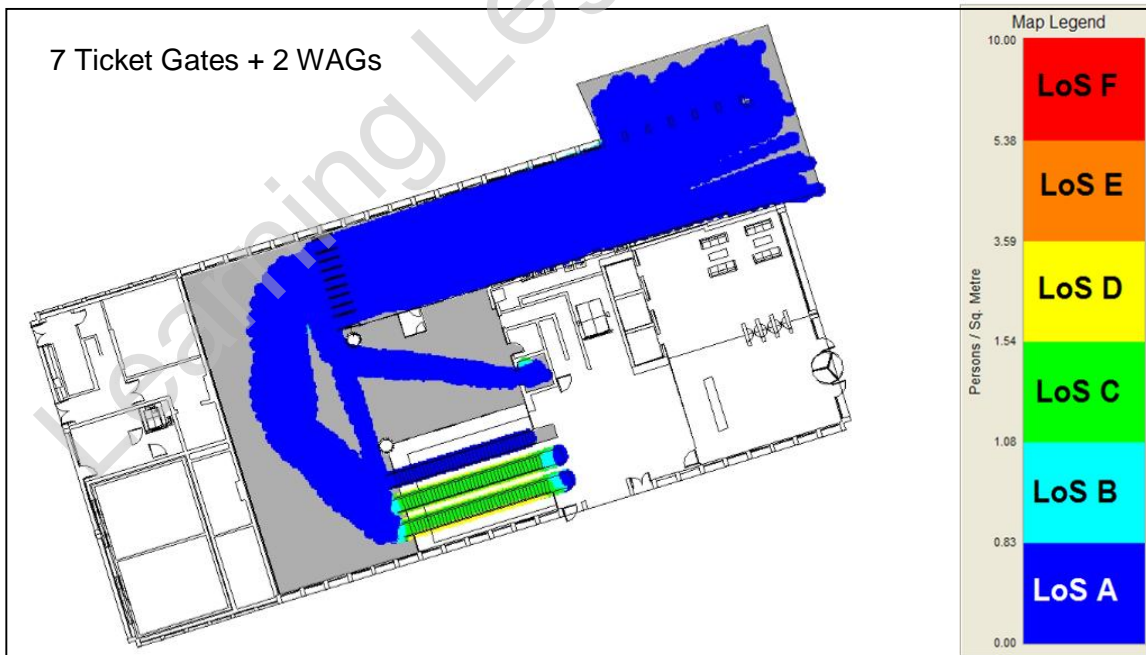
### Davies Street Ticket Hall

Figure 4.4 and Figure 4.5 show the cumulative mean density walking and queuing maps of the Davies Street ticket hall for the 2026 scenario during the AM peak hour respectively.

**Figure 4.4 - AM Peak 2026 Stage E Design Davies Street Ticket Hall Cumulative Mean Density Walking**



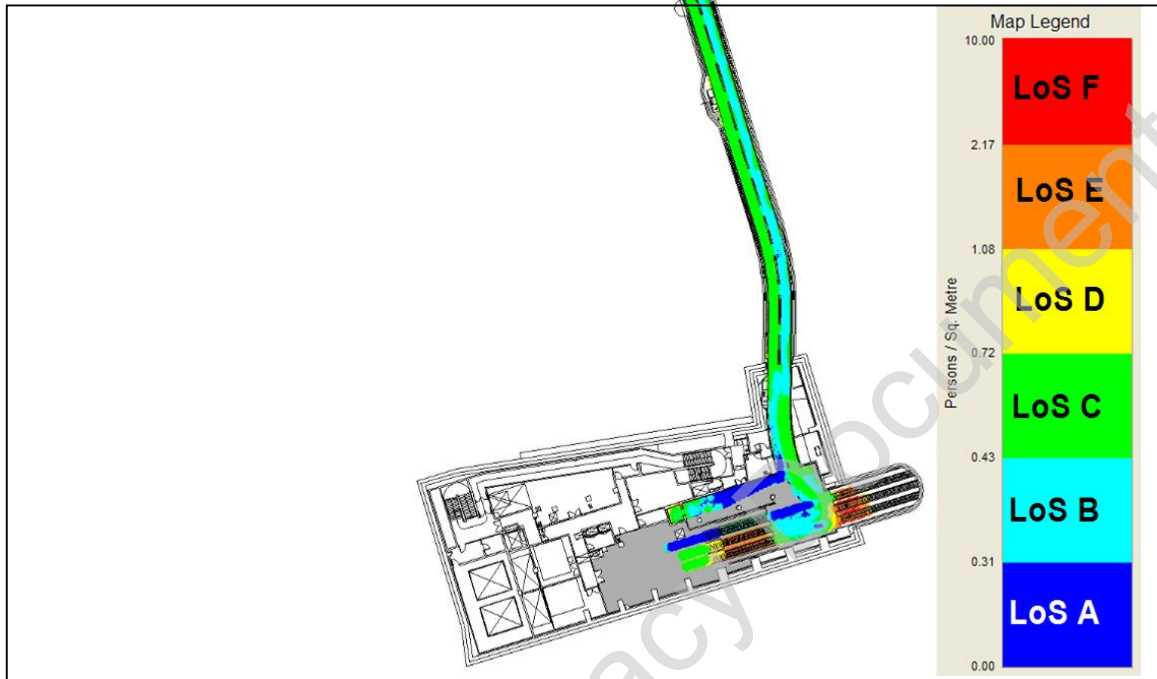
**Figure 4.5 - AM Peak 2026 Stage E Design Davies Street Ticket Hall Cumulative Mean Density Queuing**



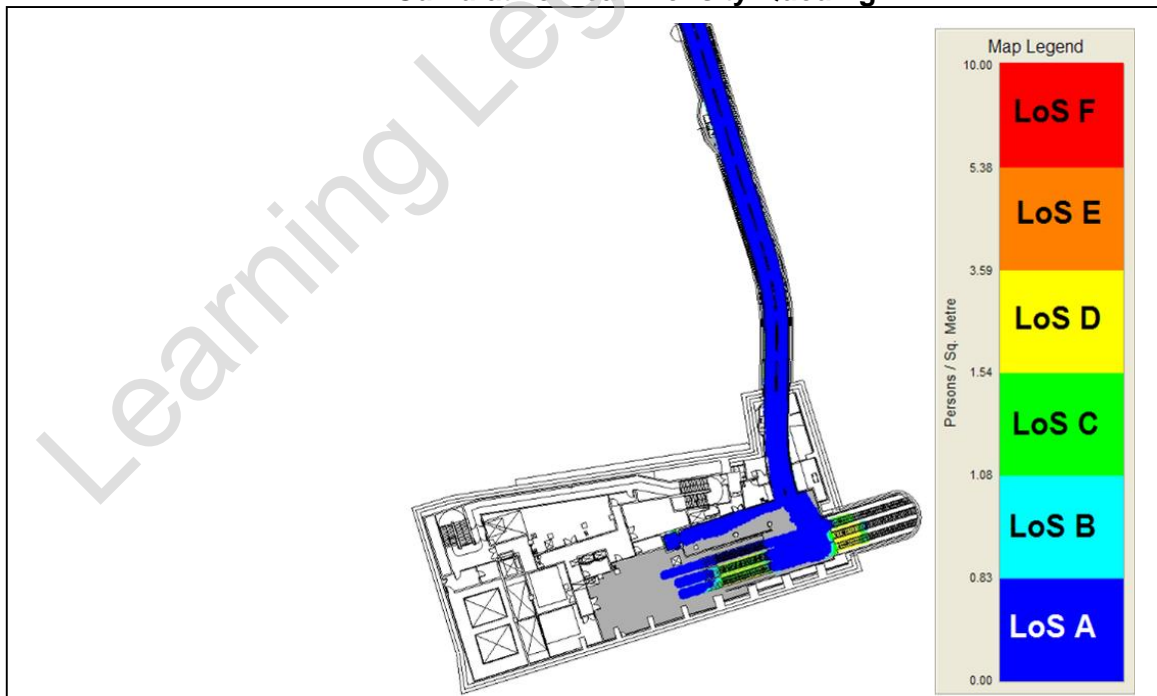
**Intermediate Level**

Figure 4.6 and Figure 4.7 show the cumulative mean density walking and queuing maps from the Stage E Design at the intermediate level for the 2026 scenarios respectively.

**Figure 4.6 - AM Peak 2026 Stage E Design Intermediate Level  
 Cumulative Mean Density Walking**



**Figure 4.7 - AM Peak 2026 Stage E Design Intermediate Level  
 Cumulative Mean Density Queuing**



### Platform Level

Figure 4.8 and Figure 4.9 show the cumulative mean density walking and queuing maps from the Stage E Design at the platform level for the AM 2026 scenarios respectively.

**Figure 4.8 - AM Peak 2026 Stage E Design Platform Level  
Cumulative Mean Density Walking**

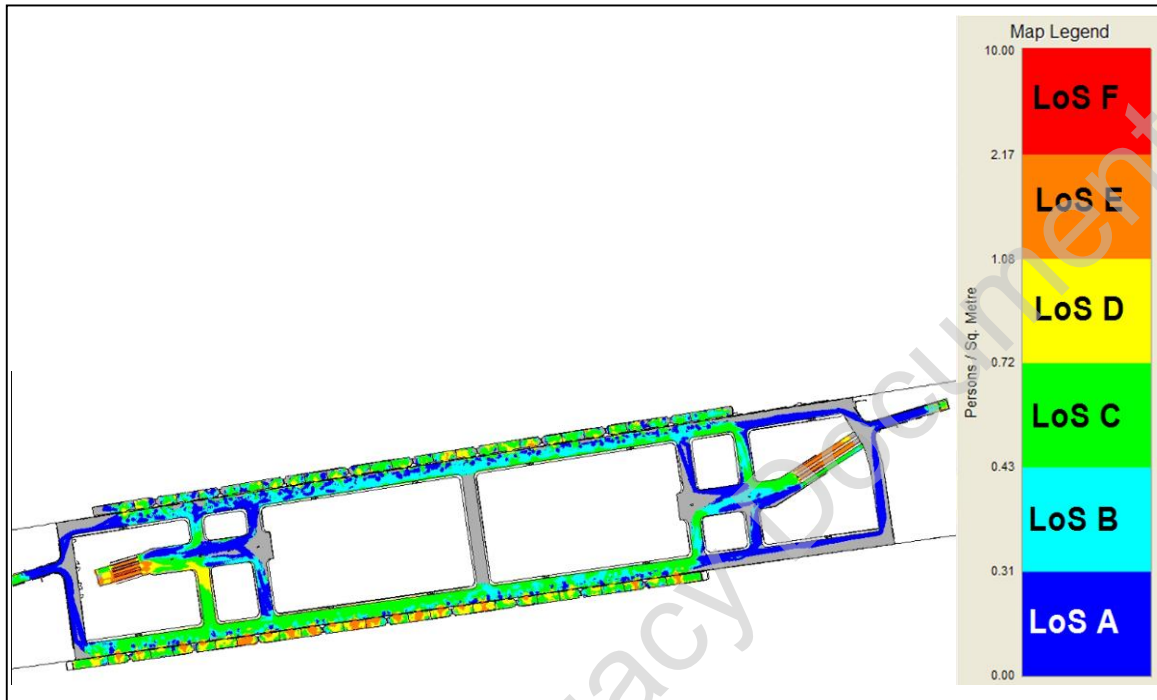
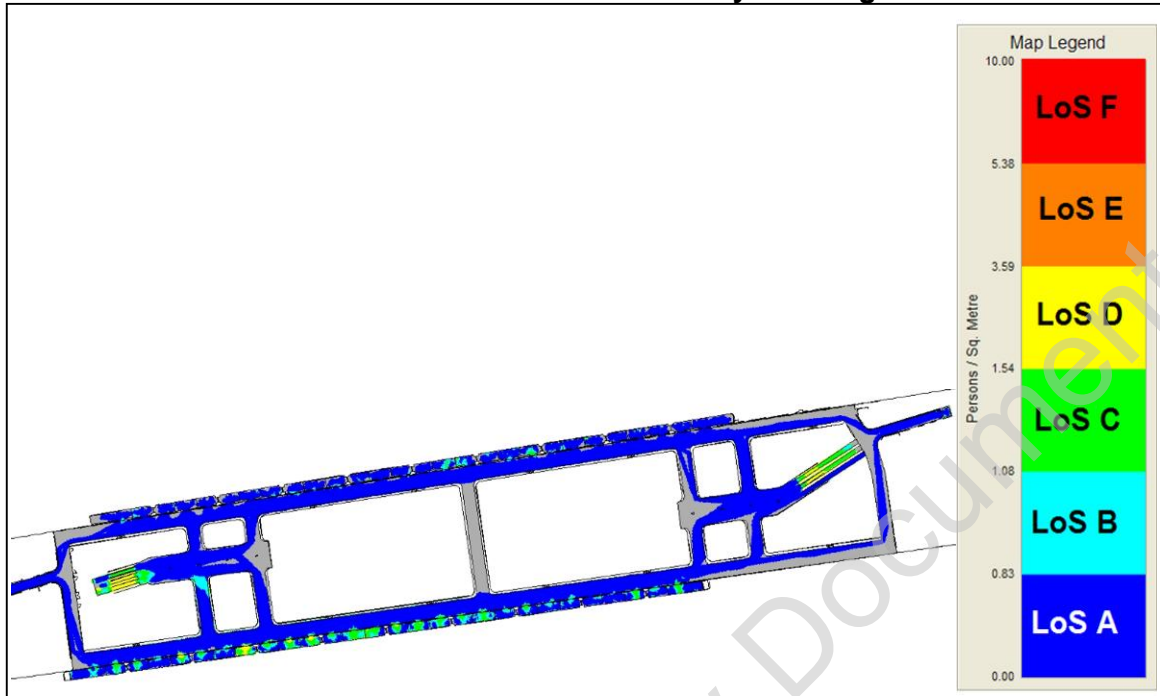


Figure 4.8 above shows that an area of walking LoS D occurs in the peak 15 minutes in the cross passageway corridor from the westbound platform to the escalators to Intermediate level (cross passageway 1). This level of service lasts for 1 minute throughout the peak 15 minutes and occurs due to the over utilisation of the cross passageway closest to the escalators and the underutilisation of the cross passageway further away from the escalators (cross passageway 2). Within the model pedestrians walking from carriages east of cross passageway 2 walk past cross passageway 2 and use cross passageway 1 to get to the escalators. In reality would not occur. It is recommended that signage directs pedestrians travelling from the carriages east of cross passageway 2 to use this cross passage.

**Figure 4.9 - AM Peak 2026 Stage E Design Platform Level  
 Cumulative Mean Density Queuing**



Learning Legacy Document

Table 4.4 summarises the 2026 AM peak densities for Bond Street Station as shown in Figure 4.2 to Figure 4.9. The table shows that almost all the LoS densities experienced for walking and queuing are all acceptable levels.

**Table 4.4 – AM Peak 2026 Pedestrian Density**

Location	Area	Walking LoS	Queuing LoS
<b>Hanover Square Ticket Hall</b>	Ticket Gates Station side		A
	Ticket Gates Entrance side		A
	At the top of escalators		A
	<b>Hanover Square Escalators</b>	<b>Max: 88ppm</b>	<b>Max: 88ppm</b>
	Walkway between escalators and ticket gates	C	
	Walkway between entrance and ticket gates	C	
<b>Davies Street Ticket Hall</b>	Ticket Gates Station side		A
	Ticket Gates Entrance side		A
	At the top of Escalators		A
	<b>Davies Street Escalators</b>	<b>Max: 72ppm</b>	<b>Max: 72ppm</b>
	Walkway between escalators and ticket gates	C	
	Walkway between entrance and ticket gates	C	
<b>Intermediate Level</b>	<b>Escalators to Davies Street</b>	<b>Max: 72ppm</b>	<b>Max: 72ppm</b>
	<b>Escalators to Platform</b>	<b>Max: 60ppm</b>	<b>Max: 60ppm</b>
	Waiting for Lift		A
	Area in front of escalator to Platform level		A
	Walkway between platform escalators and escalators to Davies Street/ LU	C	
	LU Passageway	C	
<b>Platform Level</b>	Eastbound Platform	C	A
	Westbound Platform	C	A
	Area in front of Escalators to Davies Street		C
	Corridors to escalators to Davies Street	D	
	<b>Davies Street Escalators (To intermediate level)</b>	<b>Max: 101ppm</b>	<b>Max: 101ppm</b>
	Corridor to lifts to Davies Street	A	
	Corridors to escalators to Hanover Square	C	
	Area in front of Escalators to Hanover Square		A
	Corridor to lifts to Hanover Square	A	
	<b>Hanover Square Escalators</b>	<b>Max: 88ppm</b>	<b>Max: 88ppm</b>



Whilst escalators are not assessed using Fruin LoS, they are included in Table 4.4 as a flow rate. The AM peak escalator flow rates are within acceptable levels with the exception of the escalator from platform level to the intermediate level with the highest escalator flow being 101 people per minute per metre. It is important to note that a second escalator also operates in an upward direction from platform level to the intermediate level; the maximum flow rate on the second escalator is 95 people per minute per metre. The pedestrian flow rate in AM 2026 only exceeds 100ppm for 1 second during the AM peak three hour time period. LU 1-371 states that for special events up to 3 days an escalator flow rate of up to 120 passengers a minute is acceptable.

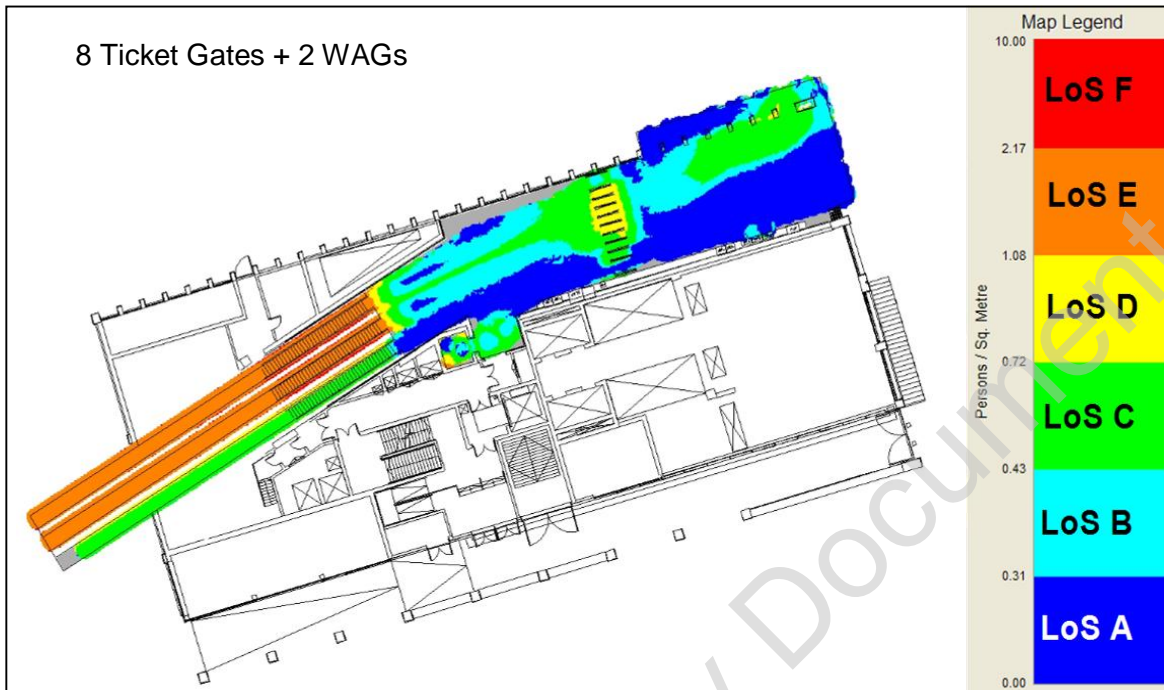
#### **4.1.8 AM Peak 2026+28% Density Maps**

The AM peak 2026+28% Stage E Design Cumulative Mean Density (CMD) plots for the peak 15 minutes (08:45-9:00) are presented in this chapter. The Cumulative High Density (CHD) and CMD maps for the 2026+28% AM peak hours in 15 minute segments can be found in Appendix F.

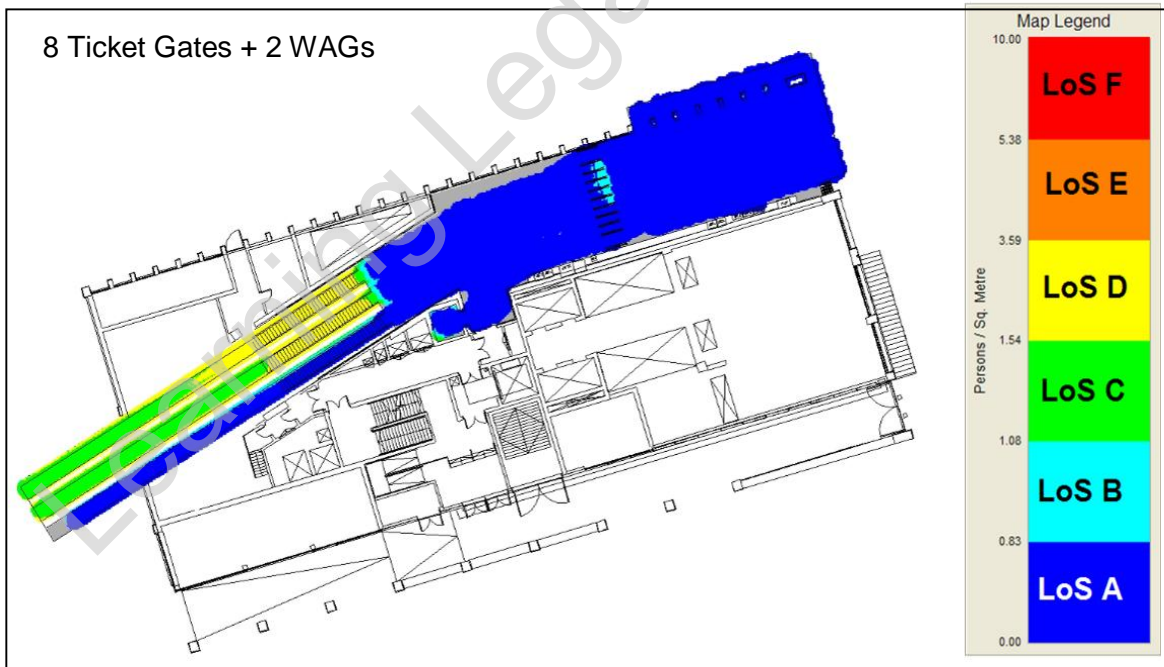
#### **Hanover Square Ticket Hall**

Figure 4.10 shows the cumulative mean density walking maps of the Hanover Square ticket hall for the 2026+28% scenario during the AM peak hour. Similarly, Figure 4.11 shows the cumulative mean density maps for queuing during the AM peak hour.

**Figure 4.10 - AM Peak 2026+28% Stage E Design Hanover Square Ticket Hall Cumulative Mean Density Walking**



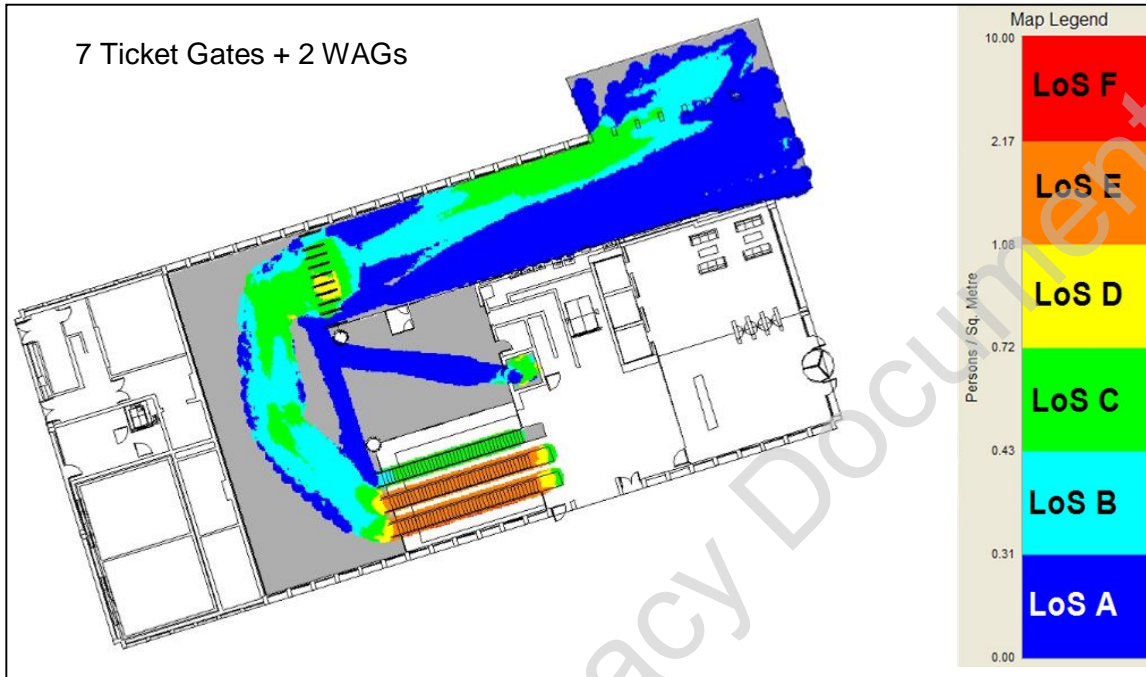
**Figure 4.11 - AM Peak 2026+28% Stage E Hanover Square Ticket Hall Cumulative Mean Density Queuing**



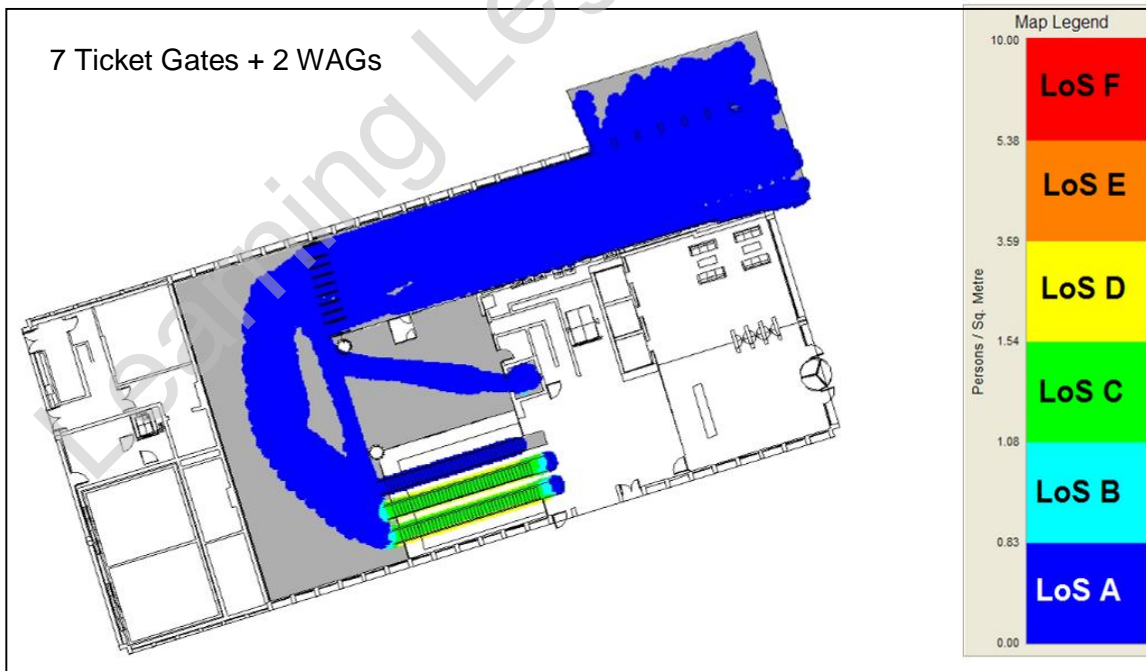
### Davies Street Ticket Hall

Figure 4.12 and Figure 4.13 shows the cumulative mean density walking and queuing maps of the Davies Street ticket hall for the 2026+28% scenario during the AM peak hour respectively.

**Figure 4.12 - AM Peak 2026+28% Stage E Design Davies Street Ticket Hall Cumulative Mean Density Walking**



**Figure 4.13 - AM Peak 2026+28% Stage E Design Davies Street Ticket Hall Cumulative Mean Density Queuing**



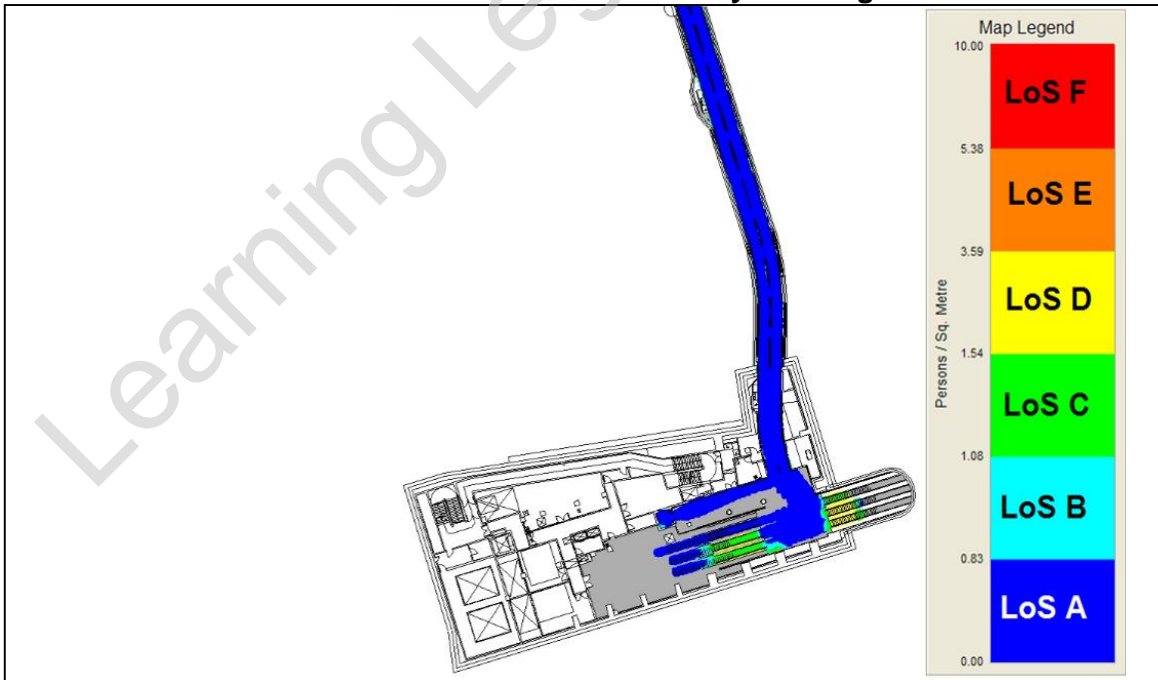
### Intermediate Level

Figure 4.14 and Figure 4.15 shows the cumulative mean density walking and queuing maps from the Stage E Design at the intermediate level for the AM peak 2026+28% scenarios respectively.

**Figure 4.14 - AM Peak 2026+28% Stage E Design Intermediate Level  
Cumulative Mean Density Walking**



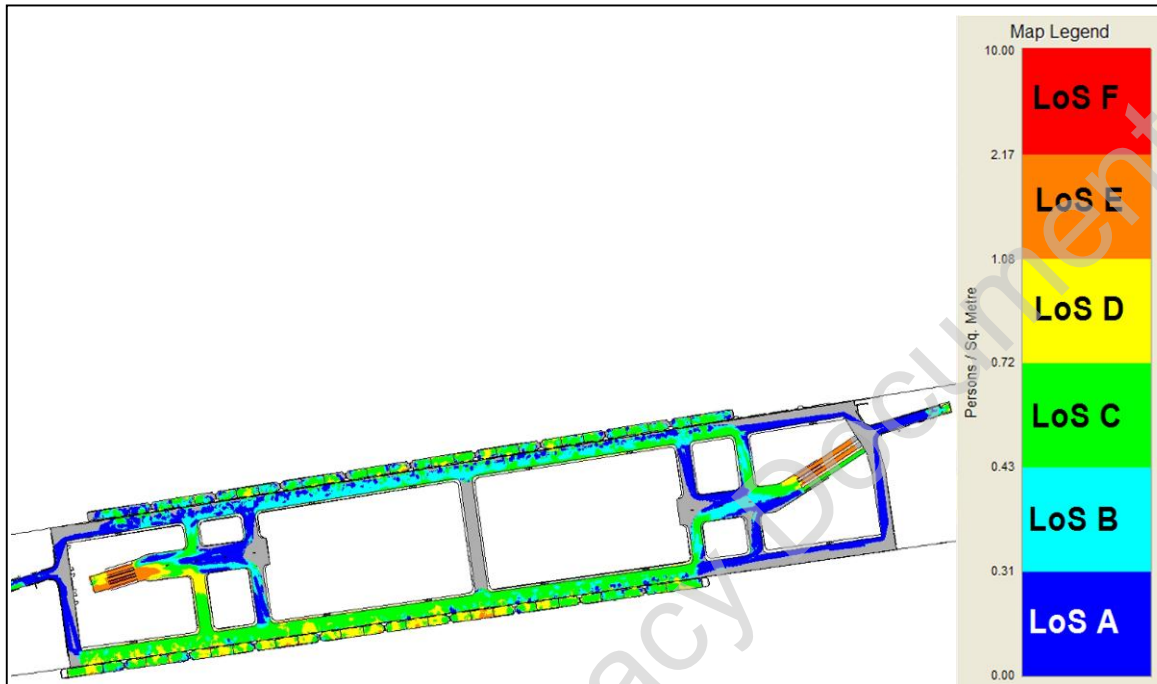
**Figure 4.15 - AM Peak 2026+28% Stage E Design Intermediate Level  
Cumulative Mean Density Queuing**



### Platform Level

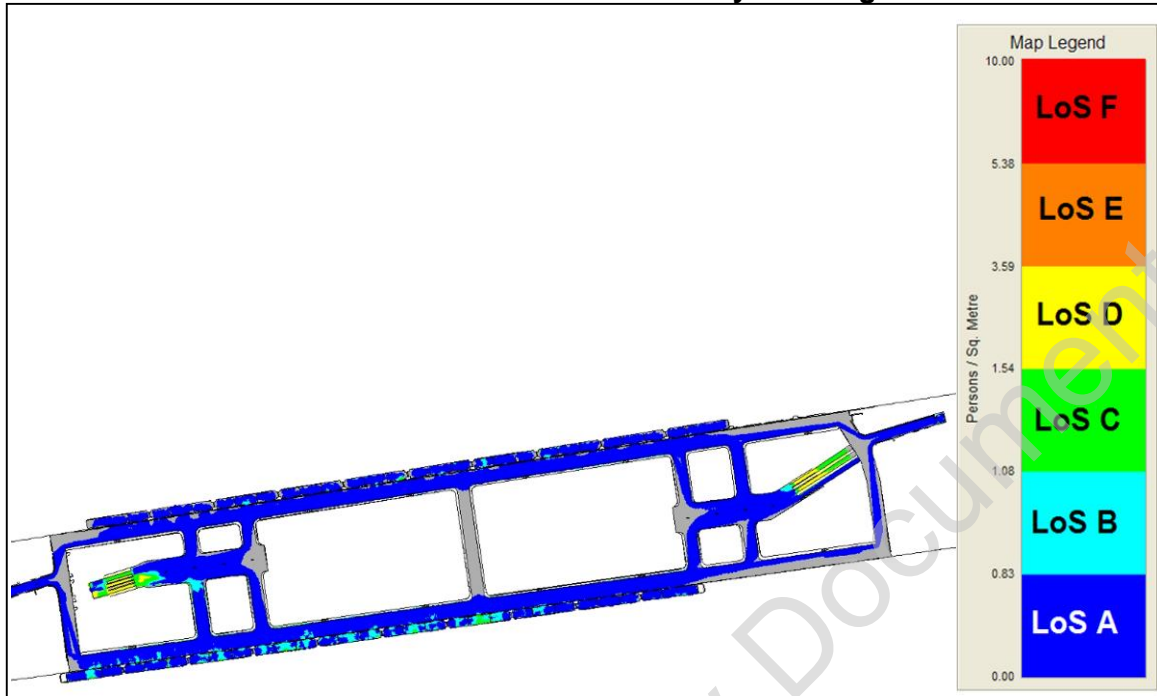
Figure 4.16 and Figure 4.17 show the cumulative mean density walking and queuing maps from the Stage E Design at the platform level for the AM peak 2026+28% scenarios respectively.

**Figure 4.16 - AM Peak 2026+28% Stage E Design Platform Level  
Cumulative Mean Density Walking**



As seen in the AM peak 2026 scenario walking level of service D occurs in the cross passageway closest to the escalators to the Intermediate level (cross passageway 1). This level of service is experienced for 1 minute during the peak 15 minutes and occurs due to the over utilisation of the cross passageway closest to the escalators and the underutilisation of the cross passageway further away from the escalators (cross passageway 2). Within the model pedestrians walking from carriages east of cross passageway 2 walk past cross passageway 2 and use cross passageway 1 to get to the escalators. In reality would not occur. It is recommended that signage directs pedestrians travelling from the carriages east of cross passageway 2 to this cross passage.

**Figure 4.17 - AM Peak 2026+28% Stage E Design Platform Level  
 Cumulative Mean Density Queuing**



Learning Legacy Document

Table 4.5 below summarises the AM peak 2026+28% densities for Bond Street Station as shown in Figure 4.10 to Figure 4.17. The table shows that all of the LoS densities experienced for walking and queuing are within acceptable levels.

**Table 4.5 – AM Peak 2026+28% Pedestrian Density**

Location	Area	Walking LoS	Queuing LoS
<b>Hanover Square Ticket Hall</b>	Ticket Gates Station side		A
	Ticket Gates Entrance side		A
	At the top of escalators		A
	<b>Hanover Square Escalators</b>	<b>Max: 98ppm</b>	<b>Max: 98ppm</b>
	Walkway between escalators and ticket gates	C	
	Walkway between entrance and ticket gates	C	
<b>Davies Street Ticket Hall</b>	Ticket Gates Station side		A
	Ticket Gates Entrance side		A
	At the top of Escalators		A
	<b>Davies Street Escalators</b>	<b>Max: 78ppm</b>	<b>Max: 78ppm</b>
	Walkway between escalators and ticket gates	C	
	Walkway between entrance and ticket gates	C	
<b>Intermediate Level</b>	<b>Escalators to Davies Street</b>	<b>Max: 78ppm</b>	<b>Max: 78ppm</b>
	<b>Escalators to Platform</b>	<b>Max: 84ppm</b>	<b>Max: 84ppm</b>
	Waiting for Lift		A
	Area in front of escalator to Platform level		A
	Walkway between platform escalators and escalators to Davies Street/ LU	C	
	LU Passageway	C	
<b>Platform Level</b>	Eastbound Platform	C	A
	Westbound Platform	C	B
	Corridors to escalators to Davies Street	D	
	Area in front of Escalators to Davies Street		C
	<b>Davies Street Escalators (To intermediate level)</b>	<b>Max: 101ppm</b>	<b>Max: 101ppm</b>
	Corridor to lifts to Davies Street	A	
	Corridors to escalators to Hanover Square	C	
	Area in front of Escalators to Hanover Square		B
	Corridor to lifts to Hanover Square	A	
	<b>Hanover Square Escalators</b>	<b>Max: 98ppm</b>	<b>Max: 98ppm</b>

Whilst escalators are not assessed using Fruin LoS, they are included Table 4.5 as a flow rates. The AM peak 2026+28% escalator flow rates are within acceptable levels with the exception of the escalator from platform level to the intermediate level with the highest escalator flow being 101 people per minute per metre. Note that a second escalator also operate in an upward direction from platform level to the intermediate level, the maximum flow rate on the second escalator is 99 people per minute per metre. The pedestrian flow rate in AM 2026+28% only exceeds 100ppm for 3 seconds during the AM peak three hour time period. LU 1-371 states that for special events up to 3 days an escalator flow rate of up to 120 passengers a minute is acceptable.

#### **4.1.9 PM Peak 2026 Density Maps**

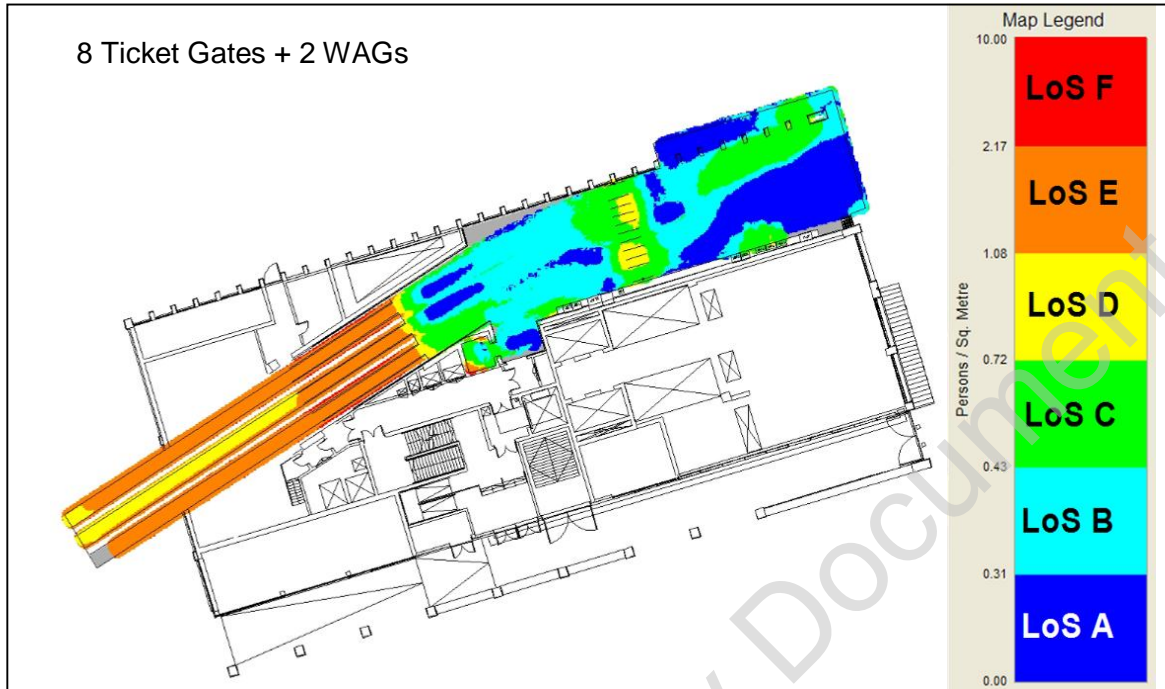
The PM peak 2026 Stage E Design Cumulative Mean Density (CMD) plots for the peak 15 minutes (17:45-18:00) are presented in this chapter. The Cumulative High Density (CHD) and CMD maps for the 2026 PM peak hours in 15 minute segments can be found in Appendix G.

##### **Hanover Square Ticket Hall**

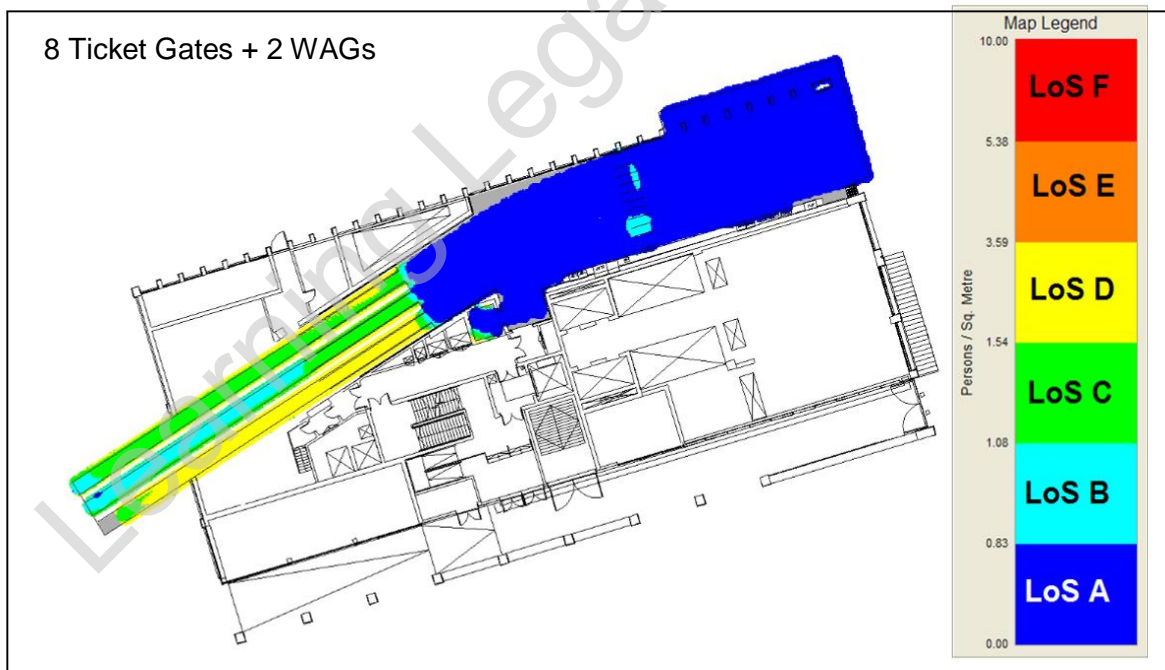
Figure 4.18 shows the cumulative mean density walking maps of the Hanover Square ticket Hall for the 2026 scenario during the PM peak hour. Similarly, Figure 4.19 shows the cumulative mean density maps for queuing during the PM peak hour.



**Figure 4.18 - PM Peak 2026 Stage E Design Hanover Square Ticket Hall  
 Cumulative Mean Density Walking**



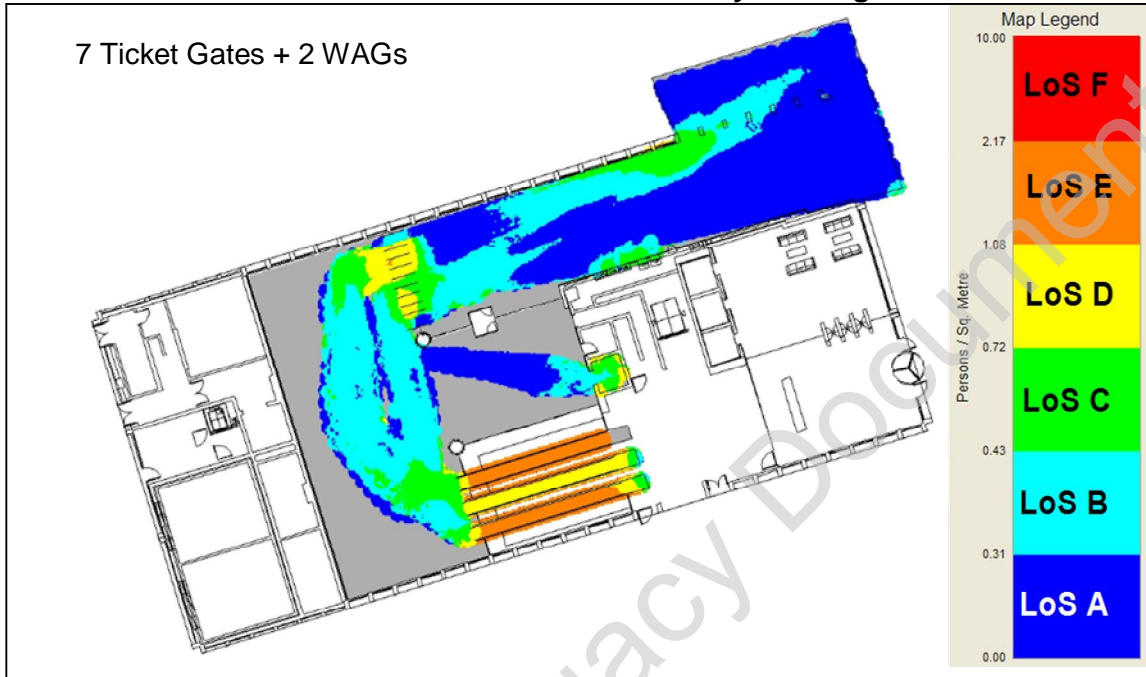
**Figure 4.19 - PM Peak 2026 Stage E Hanover Square Ticket Hall  
 Cumulative Mean Density Queuing**



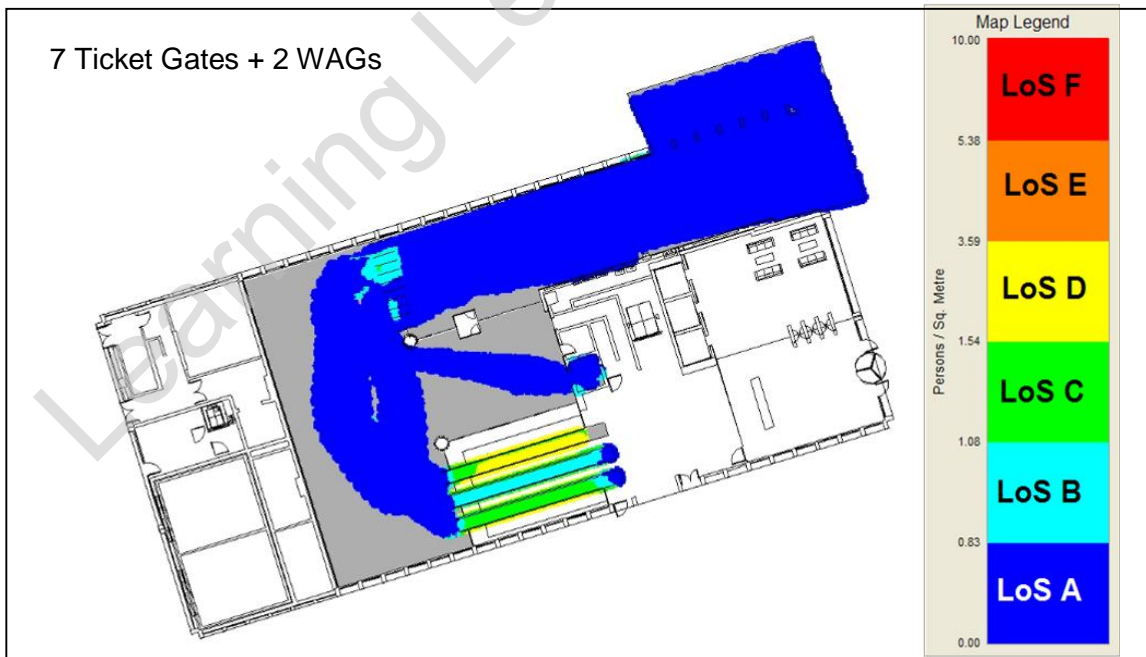
### Davies Street Ticket Hall

Figure 4.20 and Figure 4.21 show the cumulative mean density walking and queuing maps of the Davies Street ticket hall for the PM Peak 2026 scenario during the PM peak hour respectively.

**Figure 4.20 - PM Peak 2026 Stage E Design Davies Street Ticket Hall Cumulative Mean Density Walking**



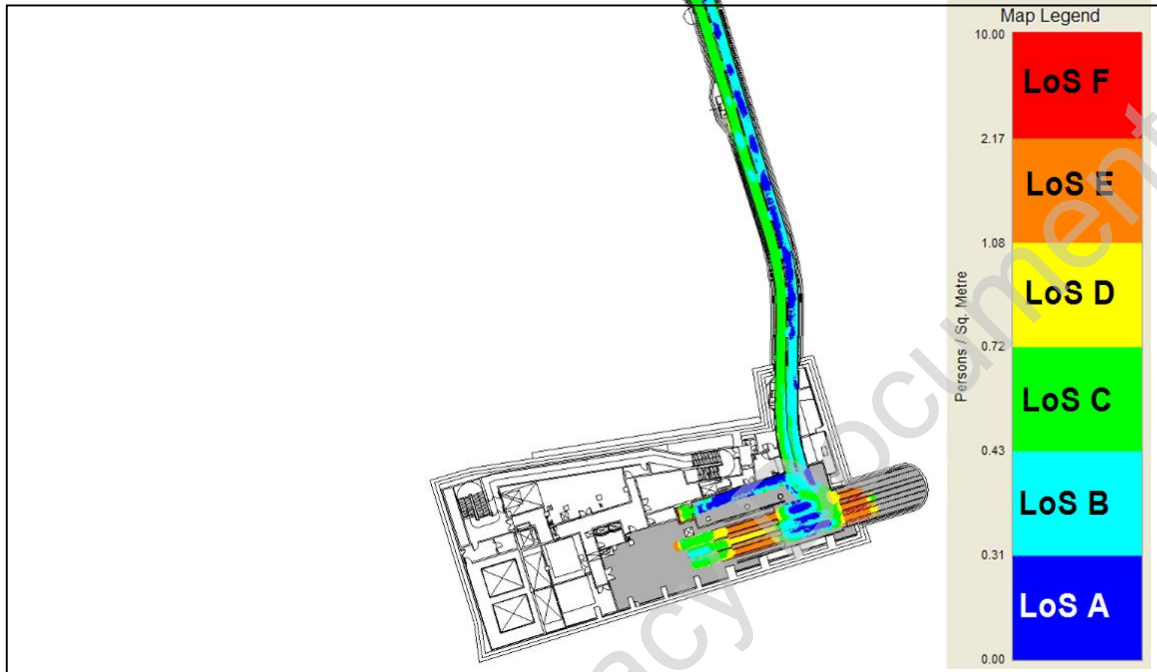
**Figure 4.21 - PM Peak 2026 Stage E Design Davies Street Ticket Hall Cumulative Mean Density Queuing**



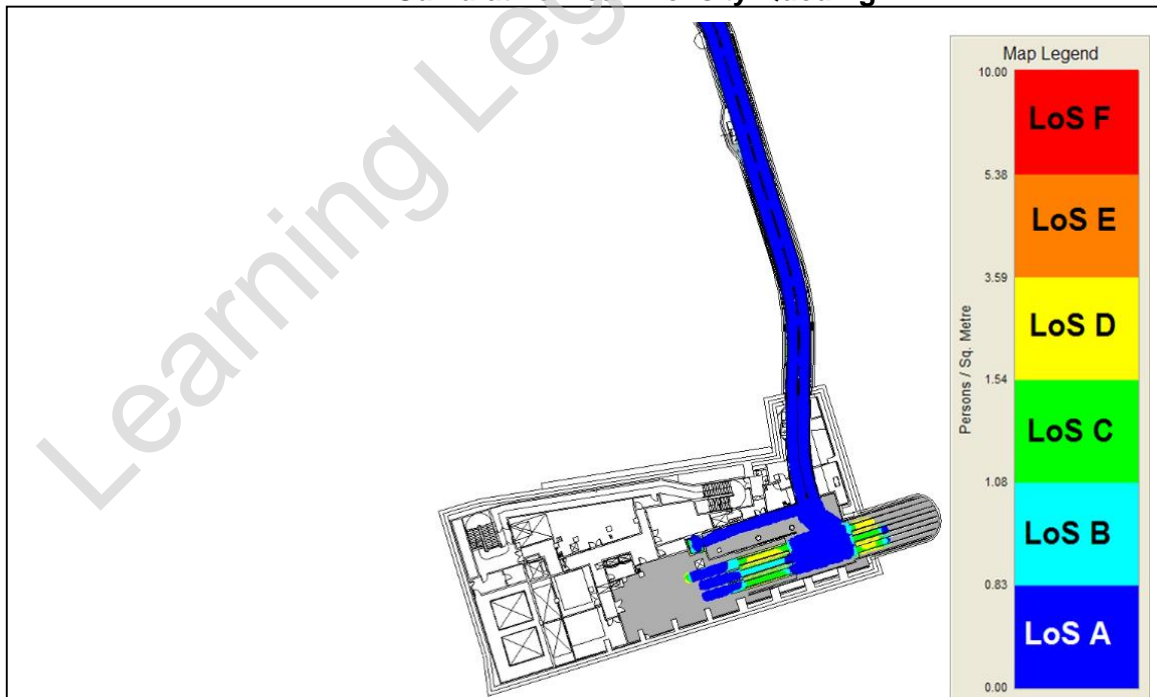
**Intermediate Level**

Figure 4.22 and Figure 4.23 show the cumulative mean density walking and queuing maps from the Stage E Design at the intermediate level for the PM Peak 2026 scenarios respectively.

**Figure 4.22 - PM Peak 2026 Stage E Design Intermediate Level  
Cumulative Mean Density Walking**



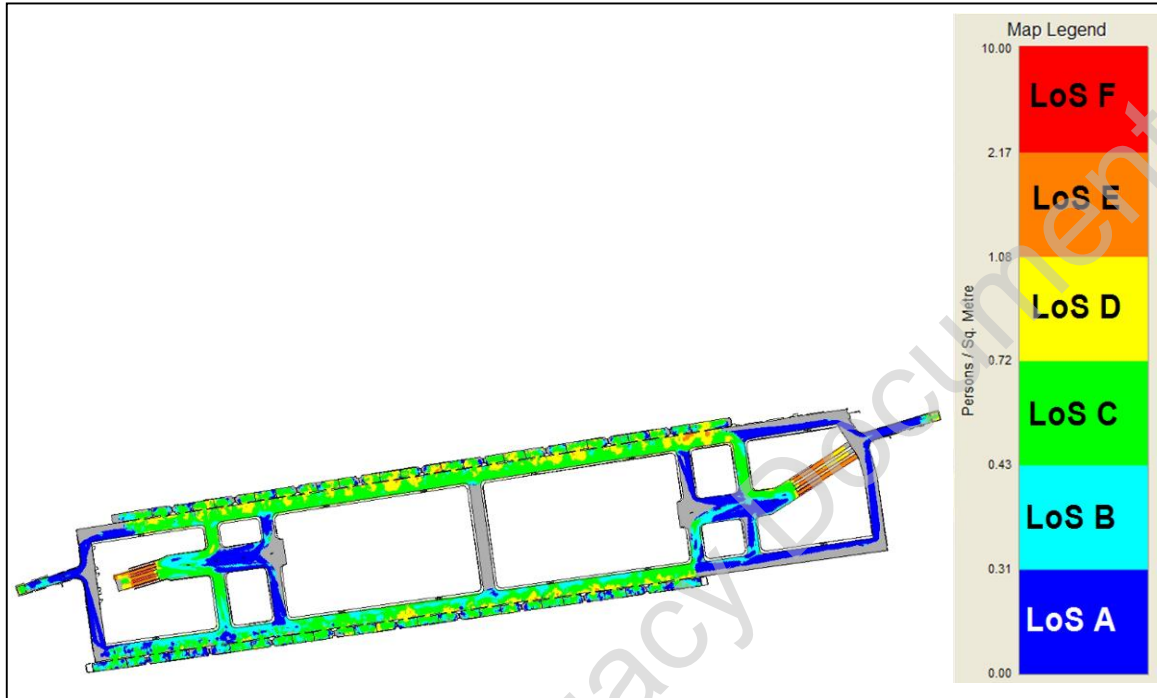
**Figure 4.23 - PM Peak 2026 Stage E Design Intermediate Level  
Cumulative Mean Density Queuing**



**Platform Level**

Figure 4.24 and Figure 4.25 show the cumulative mean density walking and queuing maps from the Stage E Design at the platform level for the PM Peak 2026 scenarios respectively.

**Figure 4.24 - PM Peak 2026 Stage E Design Platform Level  
 Cumulative Mean Density Walking**



**Figure 4.25 - PM Peak 2026 Stage E Design Platform Level  
 Cumulative Mean Density Queuing**

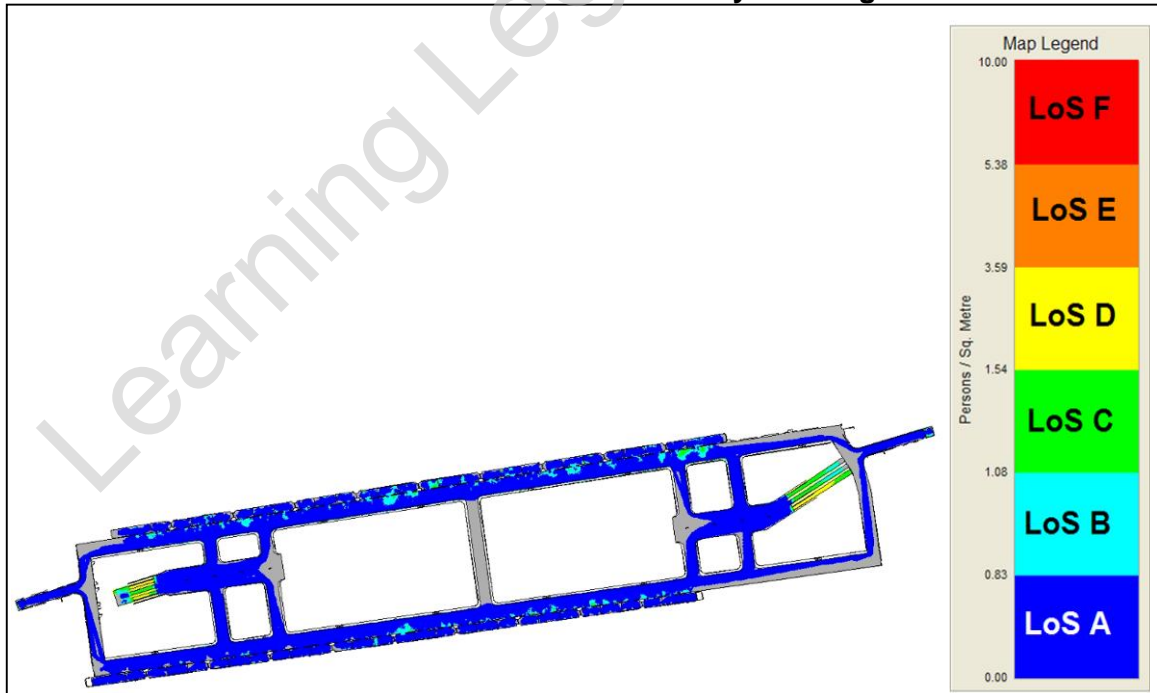


Table 4.6 below summarises the 2026 PM peak densities for the Hanover Square ticket hall, the Davies Street ticket hall, the intermediate level and the platform level as shown in Figure 4.18 to Figure 4.25. The table shows that all LoS densities experienced for walking and queuing are within acceptable levels.

**Table 4.6 – PM Peak 2026 Pedestrian Density**

Location	Area	Walking LoS	Queuing LoS
<b>Hanover Square Ticket Hall</b>	Ticket Gates Station side		B
	Ticket Gates Ticket Hall side		A
	At the top of escalators		B
	<b>Hanover Square Escalators</b>	<b>Max: 81ppm</b>	<b>Max: 81ppm</b>
	Walkway between escalators and ticket gates	C	
	Walkway between entrance and ticket gates	C	
<b>Davies Street Ticket Hall</b>	Ticket Gates Station side		B
	Ticket Gates Entrance side		A
	At the top of Escalators		A
	<b>Davies Street Escalators</b>	<b>Max: 81ppm</b>	<b>Max: 81ppm</b>
	Walkway between escalators and ticket gates	C	
	Walkway between entrance and ticket gates	C	
<b>Intermediate Level</b>	<b>Escalators to Davies Street</b>	<b>Max: 65ppm</b>	<b>Max: 65ppm</b>
	<b>Escalators to Platform</b>	<b>Max: 98ppm</b>	<b>Max: 98ppm</b>
	Waiting for Lift		A
	Area in front of escalator to Platform level		B
	Walkway between platform escalators and escalators to Davies Street/ LU	C	
	LU Passageway	C	
<b>Platform Level</b>	Eastbound Platform	C	B
	Westbound Platform	C	B
	Corridors to escalators to Davies Street	C	
	Area in front of Escalators to Davies Street		A
	<b>Davies Street Escalators (To intermediate level)</b>	<b>Max: 106ppm</b>	<b>Max: 106ppm</b>
	Corridor to lifts to Davies Street	A	
	Corridors to escalators to Hanover Square	C	
	Area in front of Escalators to Hanover Square		A
	Corridor to lifts to Hanover Square	A	
	<b>Hanover Square Escalators</b>	<b>Max: 81ppm</b>	<b>Max: 81ppm</b>

Whilst escalators are not assessed using Fruin LoS, they are included Table 4.6 as a flow rates. The escalator flow rates exceed 100ppm for approximately 20 seconds on the upward escalator between platform and Intermediate level. The highest escalator flow rate is 106 people per minute per metre. However, a second escalator also operate in an upward direction from platform level to the intermediate level, the maximum flow rate on the second escalator is 96 people per minute per metre. Furthermore LU 1-371 states that for special events up to 3 days an escalator flow rate of up to 120 passengers a minute is acceptable.

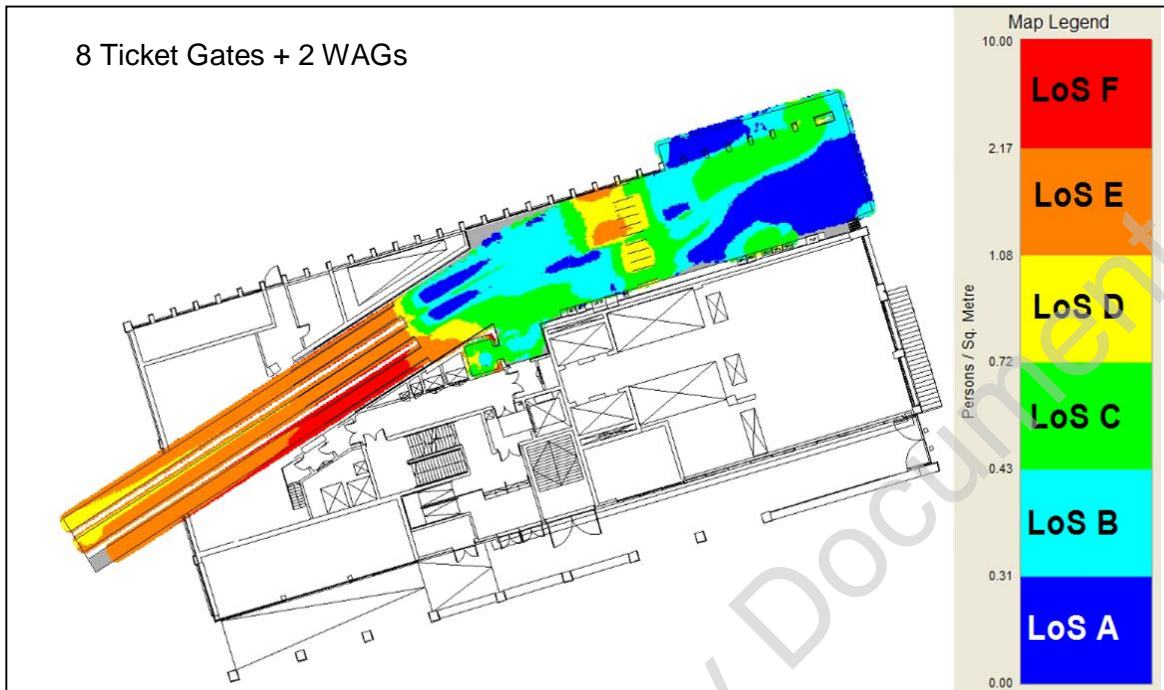
#### 4.1.10 PM Peak 2026+28% Density Maps

The PM peak 2026+28% Stage E Design Cumulative Mean Density (CMD) plots for the peak 15 minutes (17:45-18:00) are presented in this chapter. The Cumulative High Density (CHD) and CMD maps for the 2026 AM peak hours in 15 minute segments can be found in Appendix H.

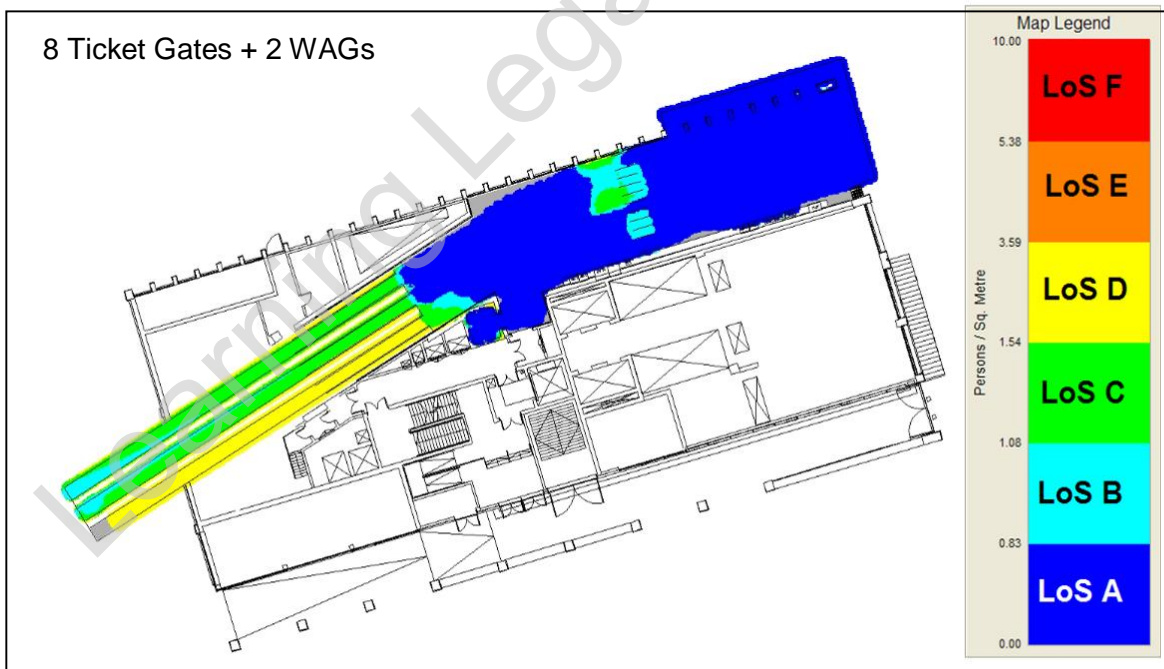
##### Hanover Square Ticket Hall

Figure 4.26 show the cumulative mean density walking maps of the Hanover Square ticket hall for the 2026+28% scenario during the PM peak hour. Similarly, Figure 4.27 show the cumulative mean density maps for queuing during the PM peak hour.

**Figure 4.26 - PM Peak 2026+28% Stage E Design Hanover Square Ticket Hall Cumulative Mean Density Walking**



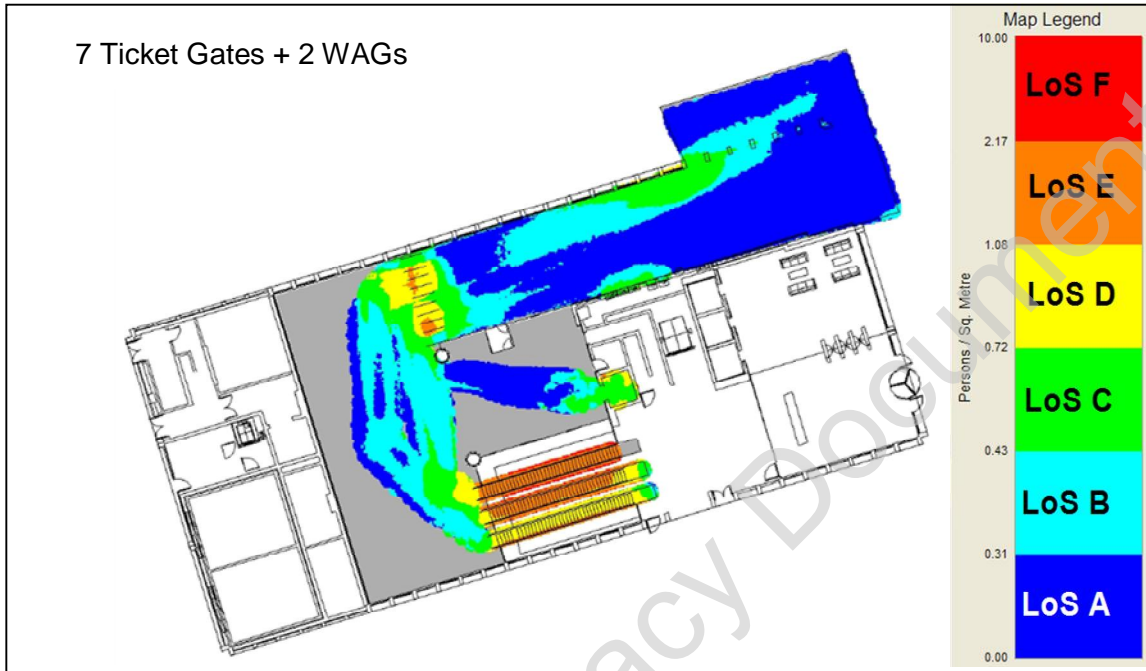
**Figure 4.27 - PM Peak 2026+28% Stage E Hanover Square Ticket Hall Cumulative Mean Density Queuing**



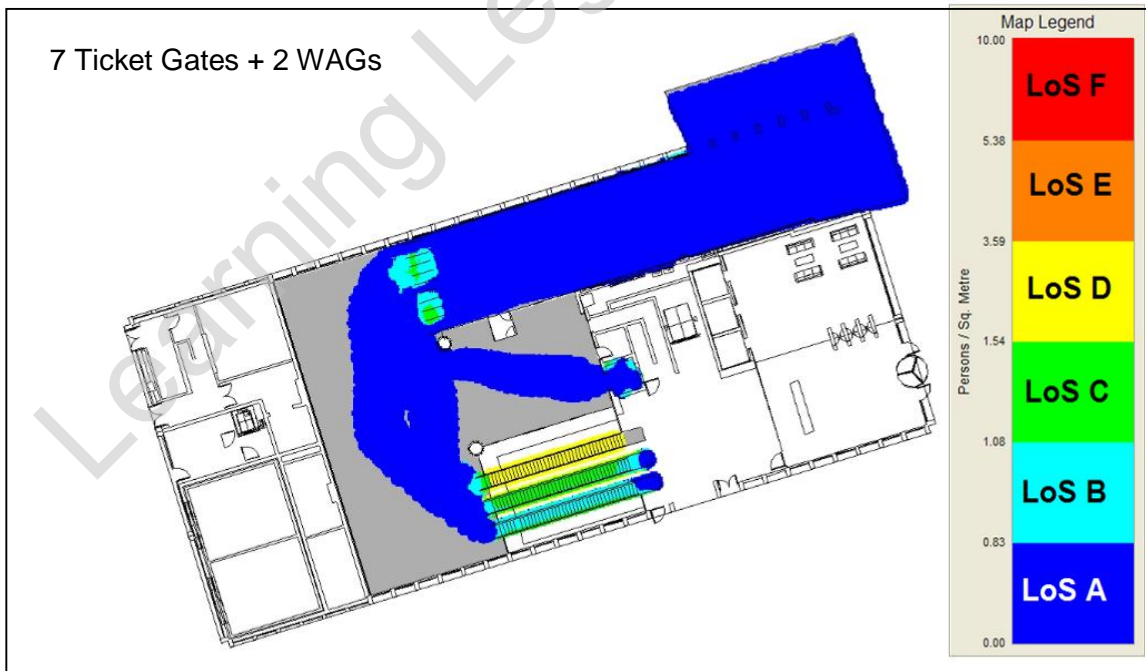
**Davies Street Ticket Hall**

Figure 4.28 and Figure 4.29 show the cumulative mean density walking and queuing maps of the Davies Street ticket hall for the 2026+28% scenario during the PM peak hour respectively.

**Figure 4.28 - PM Peak 2026+28% Stage E Design Davies Street Ticket Hall Cumulative Mean Density Walking**



**Figure 4.29 - PM Peak 2026+28% Stage E Design Davies Street Ticket Hall Cumulative Mean Density Queuing**

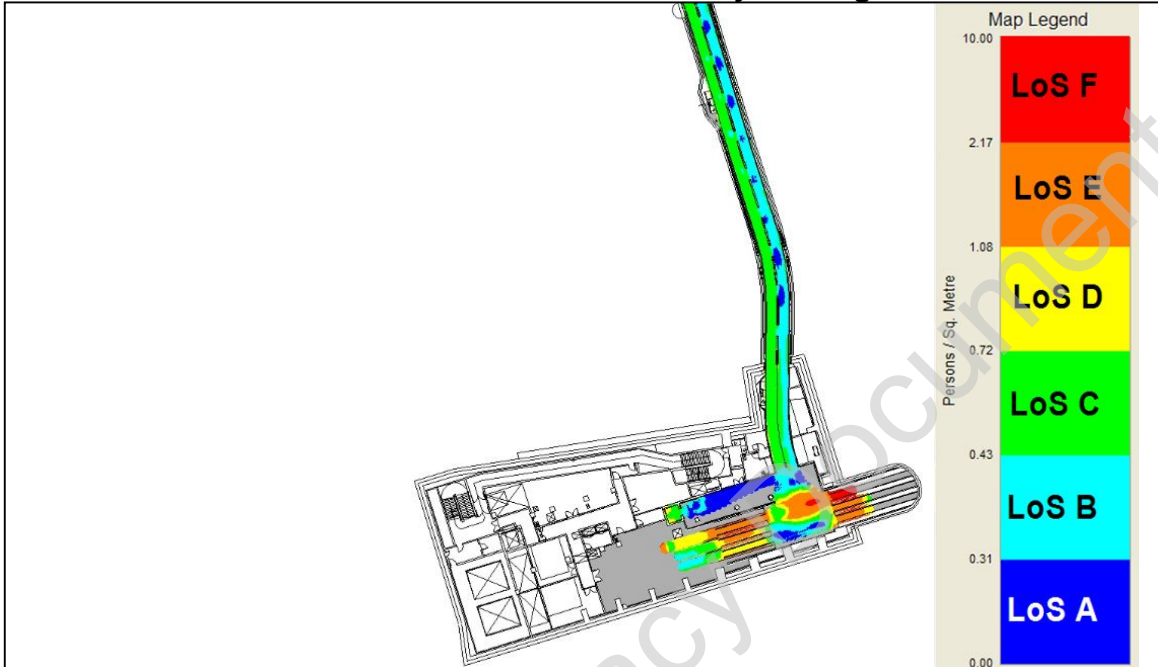




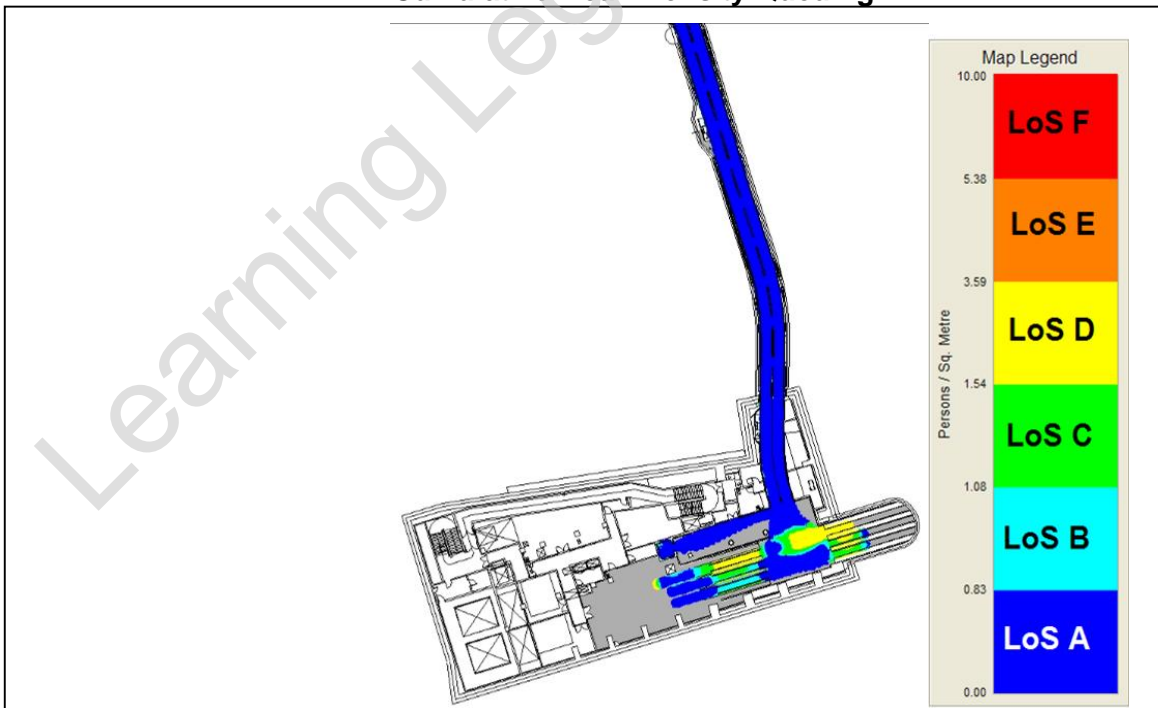
**Intermediate Level**

Figure 4.30 and Figure 4.31 show the cumulative mean density walking and queuing maps from the Stage E Design at the intermediate level for the PM peak 2026+28% scenarios respectively.

**Figure 4.30 - PM Peak 2026+28% Stage E Design Intermediate Level  
Cumulative Mean Density Walking**

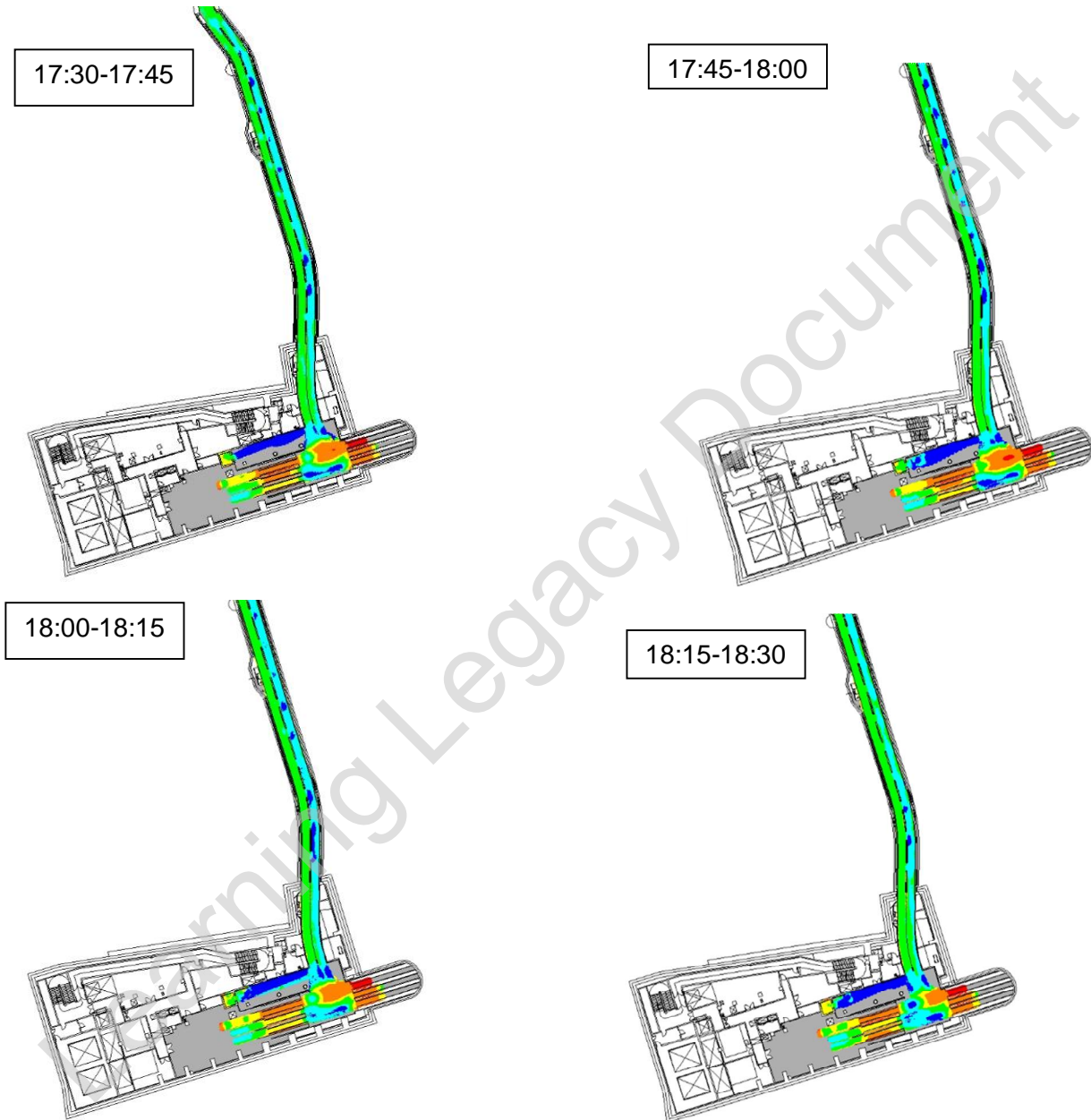


**Figure 4.31 - PM Peak 2026+28% Stage E Design Intermediate Level  
Cumulative Mean Density Queuing**



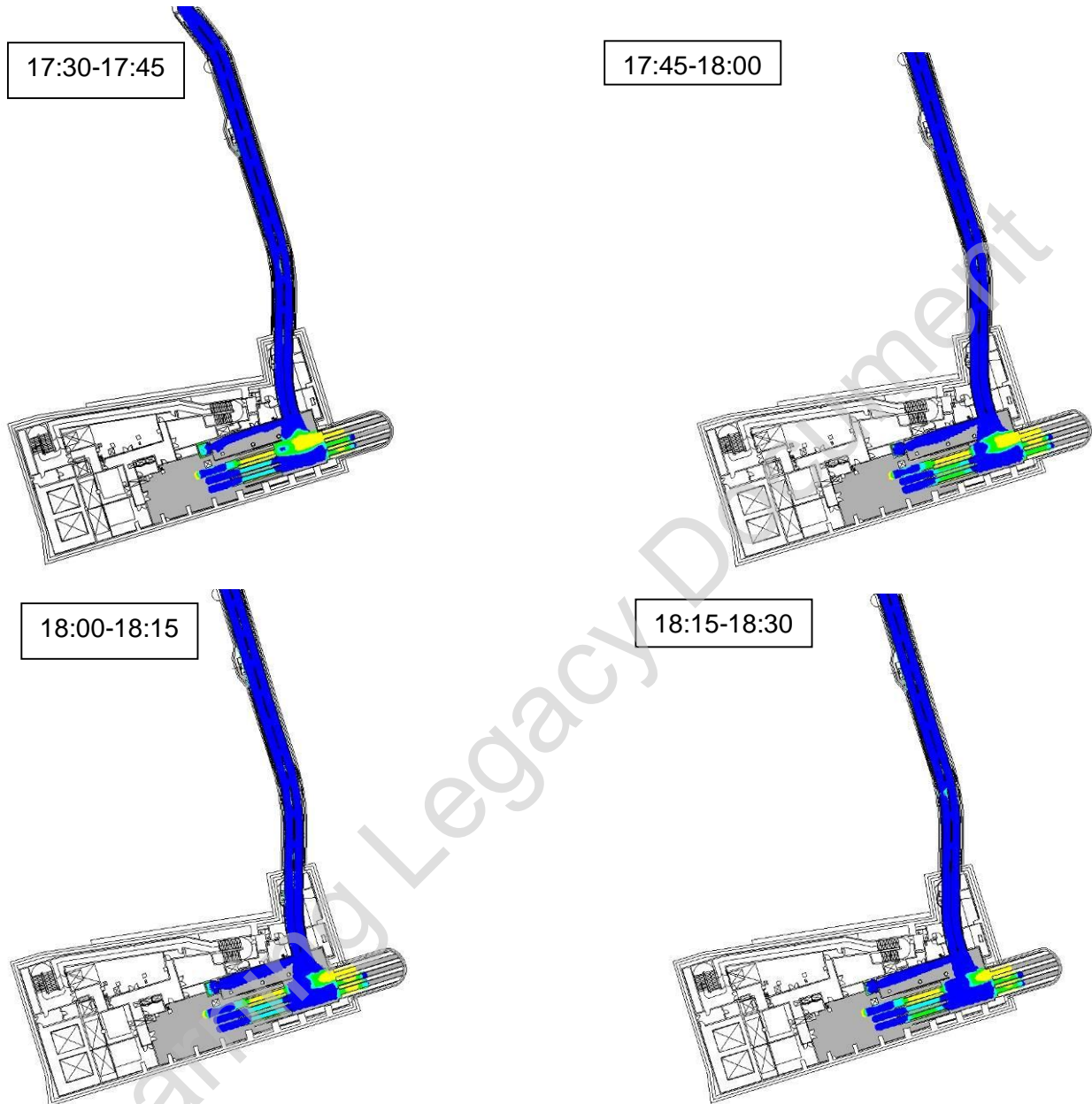
The PM peak CMD maps above indicate that at the Intermediate level both walking and queuing level of service exceeds compliant levels of service. Figure 4.32 and Figure 4.33 show all the peak 15 minute CMD maps. Chapter 5 of this report explores when between 2026 and 2026+28% the Fruin levels are exceeded (the breakpoint) and possible mitigation.

**Figure 4.32 - PM Peak 2026+28% Stage E Design Intermediate Level Cumulative Mean Density Walking**



The above maps show that walking level of service E is experienced in all 15 minute peak time periods between 17:30-18:30.

Figure 4.33 - PM Peak 2026+28% Stage E Design Intermediate Level  
Cumulative Mean Density Queuing

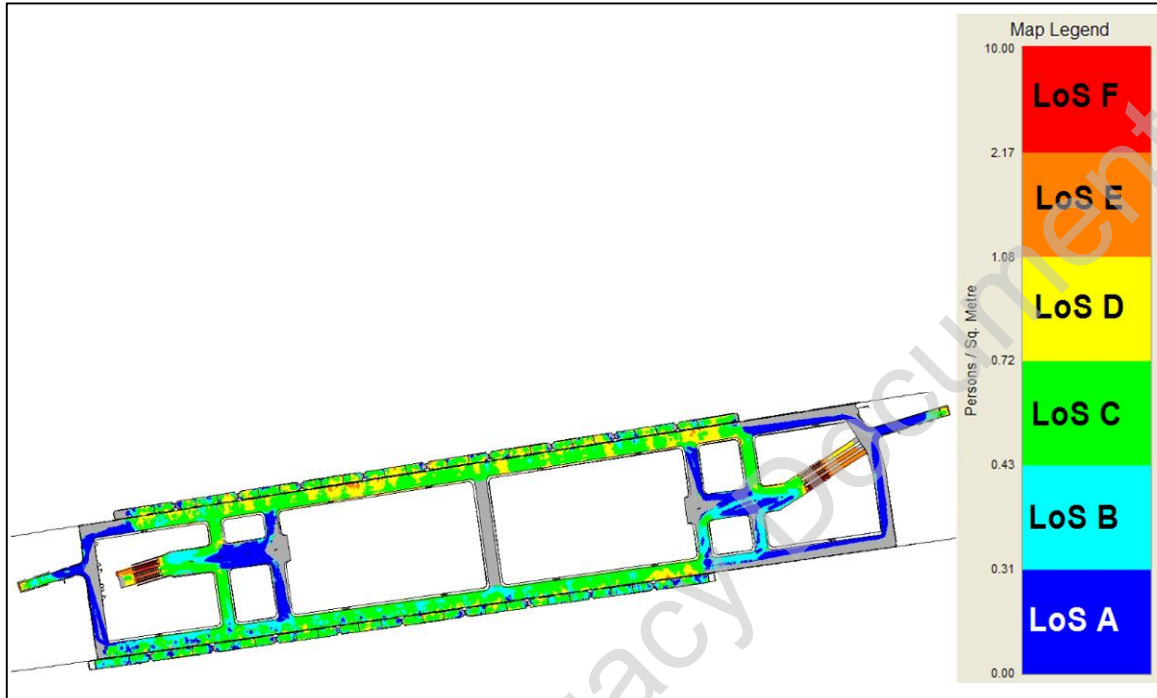


The above maps show that walking level of service D is experienced in all 15 minute peak time periods between 17:30-18:30.

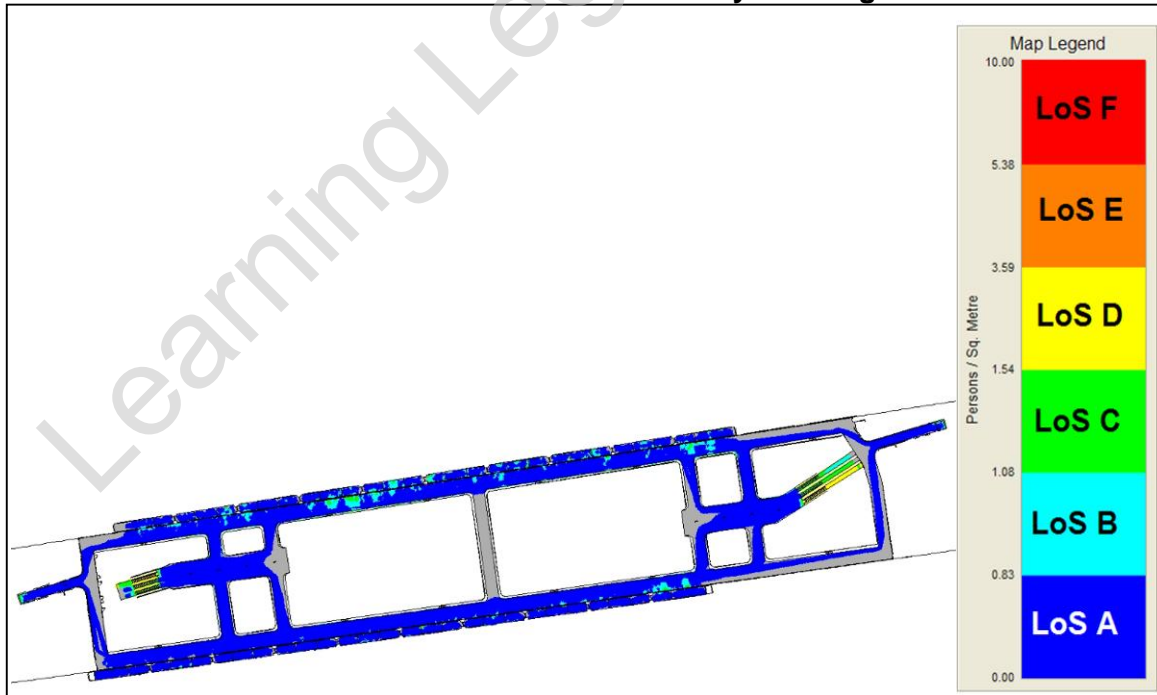
**Platform Level**

Figure 4.34 and Figure 4.35 show the cumulative mean density walking and queuing maps from the Stage E Design at the platform level for the PM peak 2026+28% scenarios respectively.

**Figure 4.34 – PM Peak 2026+28% Stage E Design Platform Level  
 Cumulative Mean Density Walking**

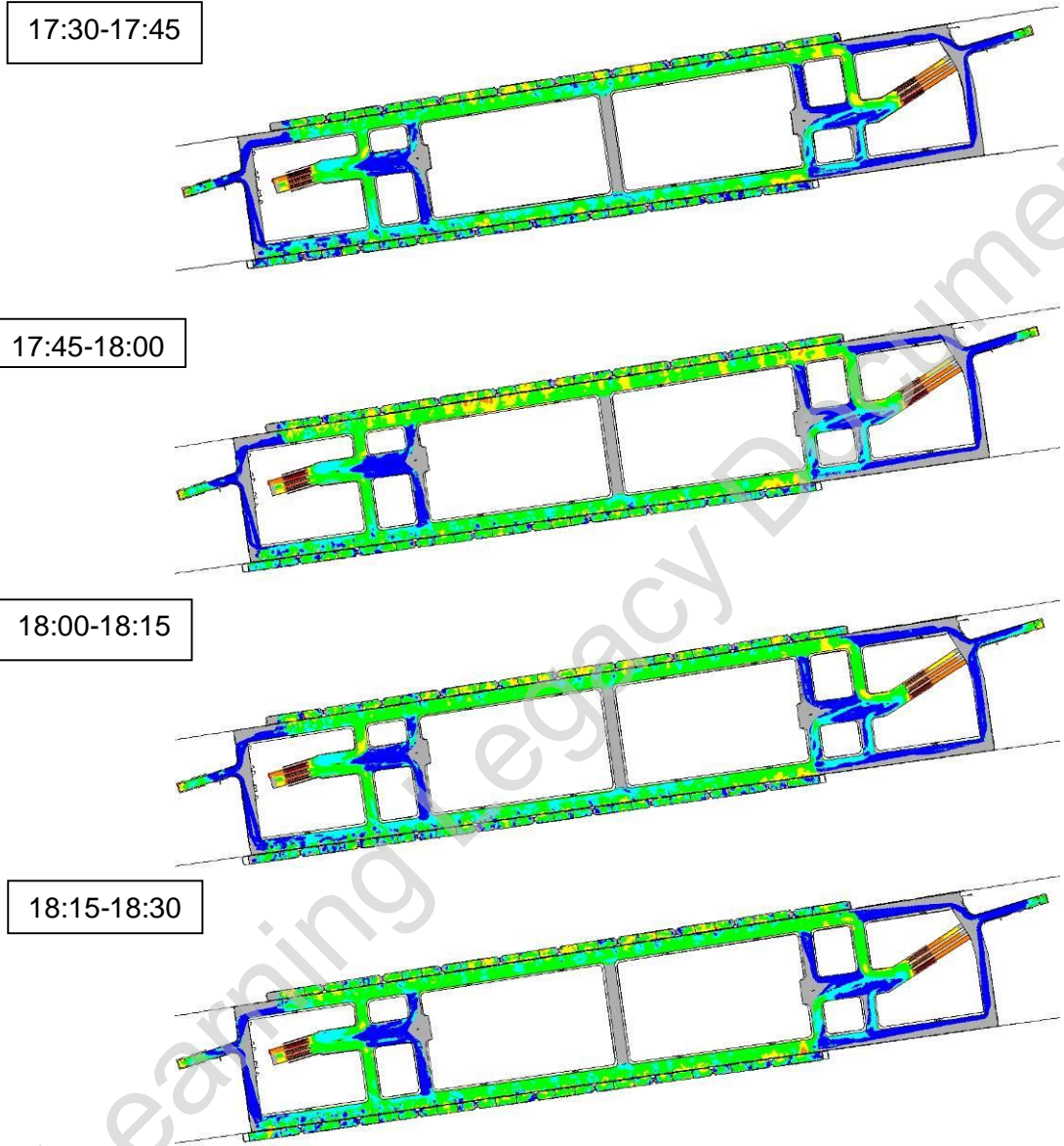


**Figure 4.35 - PM Peak 2026+28% Stage E Design Platform Level  
 Cumulative Mean Density Queuing**



The PM peak CMD maps above indicate that at the platform level walking level of service exceeds compliant levels of service. Figure 4.36 show all the peak 15 minute CMD maps.

**Figure 4.36 - PM Peak 2026+28% Stage E Design Intermediate Level Cumulative Mean Density Walking**



The above maps show that walking level of service D at the back of the platform is only experienced in the peak 15 minute between 17:45-18:00. This is the time when the cancelled train occurs within the model.

**Table 4.7 – PM Peak 2026+28% Pedestrian Density**

Location	Area	Walking LoS	Queuing LoS
<b>Hanover Square Ticket Hall</b>	Ticket Gates Station side		C
	Ticket Gates Entrance side		B
	At the top of escalators		C
	<b>Hanover Square Escalators</b>	<b>Max: 106ppm</b>	<b>Max: 106ppm</b>
	Walkway between escalators and ticket gates	C	
	Walkway between entrance and ticket gates	C	
<b>Davies Street Ticket Hall</b>	Ticket Gates Station side		B
	Ticket Gates Entrance side		A
	At the top of Escalators		B
	<b>Davies Street Escalators</b>	<b>Max: 90ppm</b>	<b>Max: 90ppm</b>
	Walkway between escalators and ticket gates	C	
	Walkway between entrance and ticket gates	C	
<b>Intermediate Level</b>	<b>Escalators to Davies Street</b>	<b>Max: 53ppm</b>	<b>Max: 53ppm</b>
	<b>Escalators to Platform</b>	<b>Max: 102ppm</b>	<b>Max: 102ppm</b>
	Waiting for Lift		A
	Area in front of escalator to Platform level		D
	Walkway between platform escalators and escalators to Davies Street/ LU	F	
	LU Passageway	C	
<b>Platform Level</b>	Eastbound Platform	D	C
	Westbound Platform	C	B
	Corridors to escalators to Davies Street	C	
	Area in front of Escalators to Davies Street		A
	<b>Davies Street Escalators (To intermediate level)</b>	<b>Max: 92ppm</b>	<b>Max: 92ppm</b>
	Corridor to lifts to Davies Street	A	
	Corridors to escalators to Hanover Square	C	
	Area in front of Escalators to Hanover Square		A
	Corridor to lifts to Hanover Square	A	
	<b>Hanover Square Escalators</b>	<b>Max: 87ppm</b>	<b>Max: 87ppm</b>

Whilst escalators are not assessed using Fruin LoS, they are included Table 4.7 as a flow rates. The escalator flow rates exceed 100ppm on the downward escalator between the Intermediate level and the platform level, with the highest escalator flow rate of 102 people per minute per metre. The downward escalator between the Hanover Square ticket hall and the platform level also exceed the escalator flow rate of 100ppm with a maximum escalator flow rate of 106ppm. A flow rate of over 100 is experienced for 4min and 10 seconds throughout the 3 hour period. However LU 1-371 states that for special events up to 3 days an escalator flow rate of up to 120 passengers a minute is acceptable.

#### 4.1.11 Summary

##### AM Peak 2026

Overall the AM peak 2026 scenario meets Crossrail pedestrian level of service criteria. The only area where level of service is non-compliant is in the westbound platform cross passageway to Davies Street escalators which has occurred as a result of the coding within the pedestrian model. This is unlikely to occur in reality with signage in place to direct people to the underutilised cross passageway. The maximum escalator flow rates on the escalators between platform and Intermediate level do exceed the recommended 100ppm in this scenario, however the pedestrian flow rate in AM 2026 only exceeds 100ppm for 1 second during the peak three hour time period which is considered to be very minor.

##### PM Peak 2026

Overall the PM peak 2026 scenarios meet Crossrail pedestrian level of service criteria. The maximum escalator flow rates on the escalators between platform and Intermediate level do exceed the recommended 100ppm for approximately 20 seconds during the peak three hour period which is considered to be a very small amount of time.

##### AM Peak 2026+28%

The AM peak 2026+28% scenario meets Crossrail pedestrian level of service criteria. The only area where level of service is non-compliant is in the westbound platform cross passageway to Davies Street escalators which has occurred as a result of the coding within the pedestrian model. This is unlikely to occur in reality with signage in place to direct people to the underutilised cross passageway. The maximum escalator flow rates on the escalators between platform and Intermediate level do exceed the recommended 100ppm for this scenario, however the pedestrian flow rate only exceeds 100ppm for 3 seconds during the peak three hour time period which is considered to be very minor.

##### PM Peak 2026+28%

At both the Hanover Square and Davies Street ticket halls, the PM 2026+28% scenario meets Crossrail pedestrian level of service criteria. However high levels of service are experienced at the Intermediate and platform level that exceed Crossrail criteria. Escalator flow rates for two of the escalators also exceed the maximum escalator flow rates of 100ppm. However, it is important to note that no escalator exceed a flow rate of over 120 ppm which is consider acceptable according to LU 1-371 for special events lasting up to 3 days. Chapter 5 discusses the breakpoint modelling and identifies when the platform and Intermediate area become non-compliant.

## 5 Breakpoint Modelling Results

### 5.1.1 Introduction

This chapter of the report identifies the year when the non-compliance at the Intermediate and platform Level in the PM peak occurs. A series of model runs were completed to find the breakpoint are as follows:

- PM 2026+7%
- PM 2026+14%
- PM 2026+21%

To generate the above model runs the PM 2026 model was used as a basis for these runs and percentage uplift applied to the pedestrian demand. The above scenarios were agreed with LU and CRL.

The breakpoint modelling was completed with close communication with LU and Crossrail. Appendix M contains the breakpoint presentation completed for LU and Crossrail along with an e-mail from LU confirming the breakpoints scenarios.

### 5.1.2 Intermediate Level Results

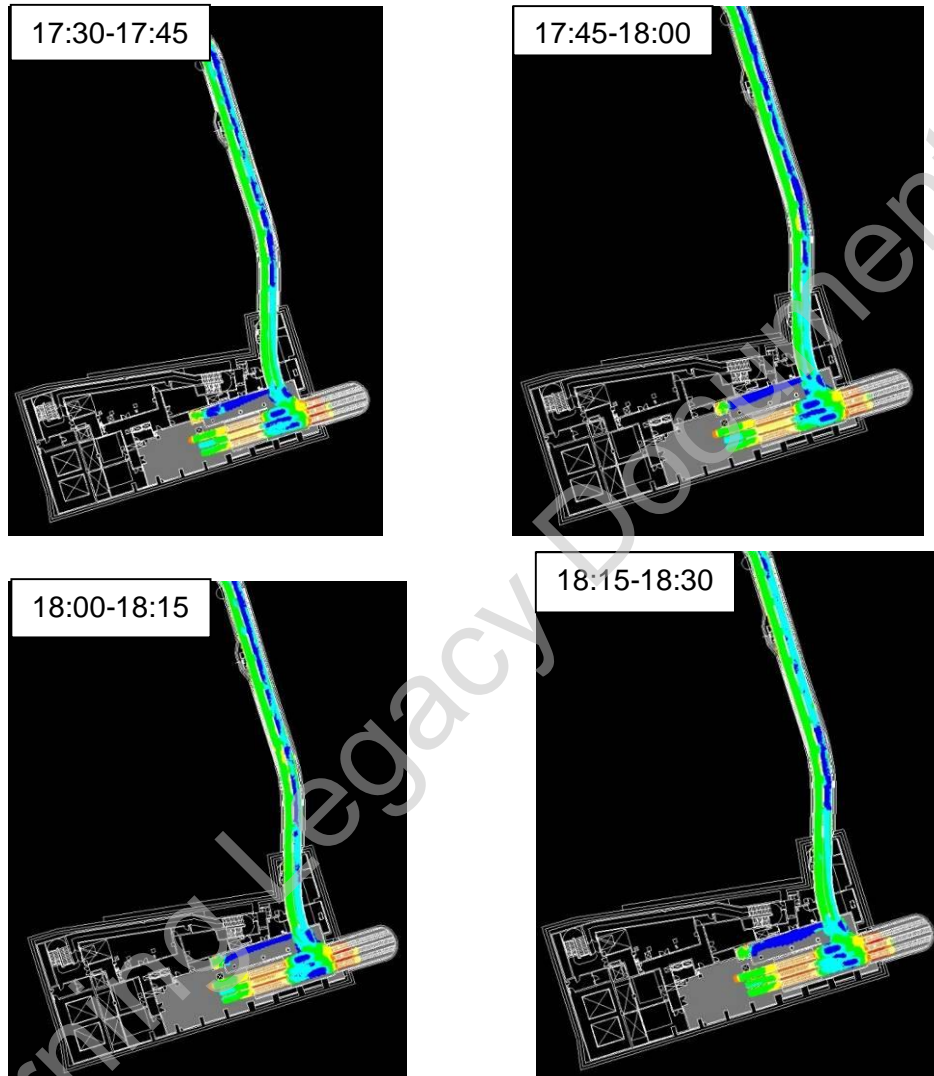
This section of the report displays the PM 2026 results for +7%, +14% and +21% for the Intermediate level, for queuing and walking level of service.



**PM 2026+7%**

Figure 5.1 illustrates the PM peak 2026+7% walking level of service results on the Intermediate level.

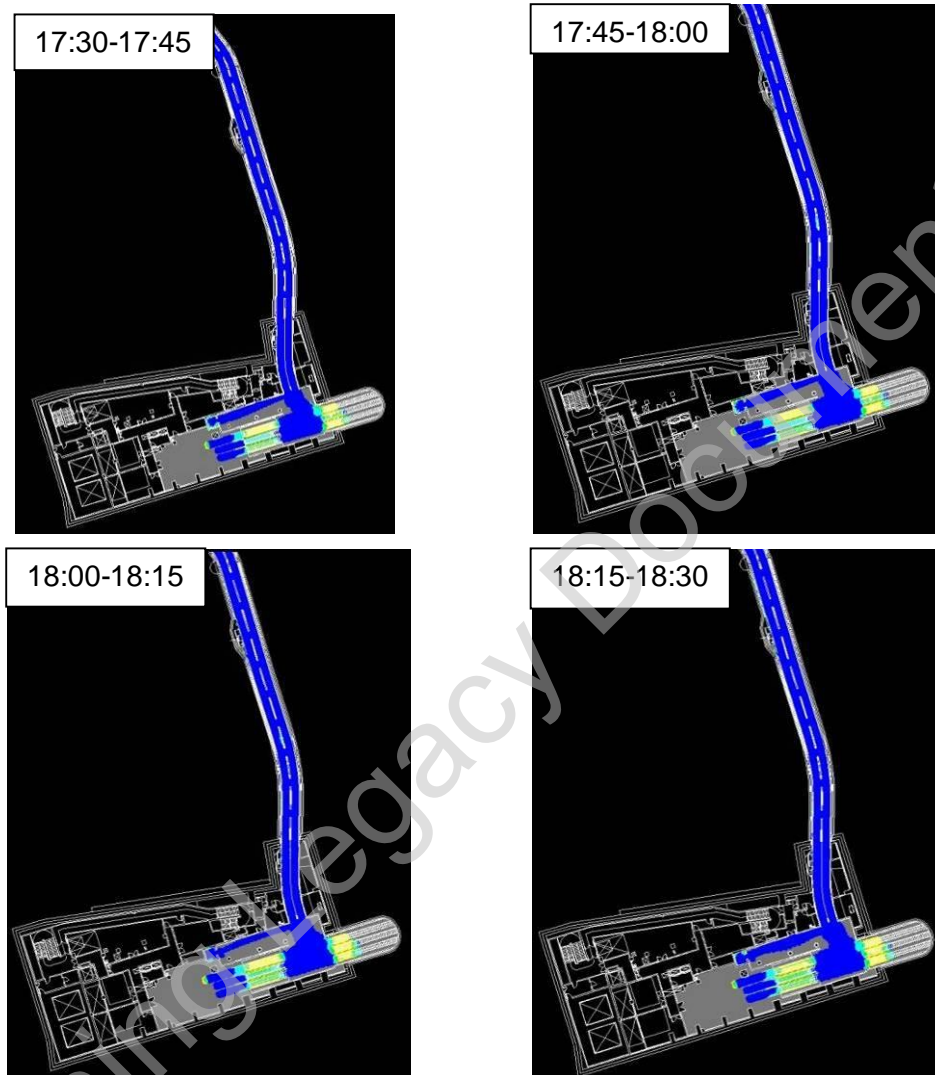
**Figure 5.1 – PM Peak 2026+7% Intermediate Level Walking Level of Service**



The figures above show that the Intermediate level is compliant in a 2026+7% scenario.

Figure 5.2 illustrates the PM peak 2026+7% queuing level of service results for the Intermediate level.

**Figure 5.2 – PM Peak 2026+7% Intermediate Level Queuing Level of Service**

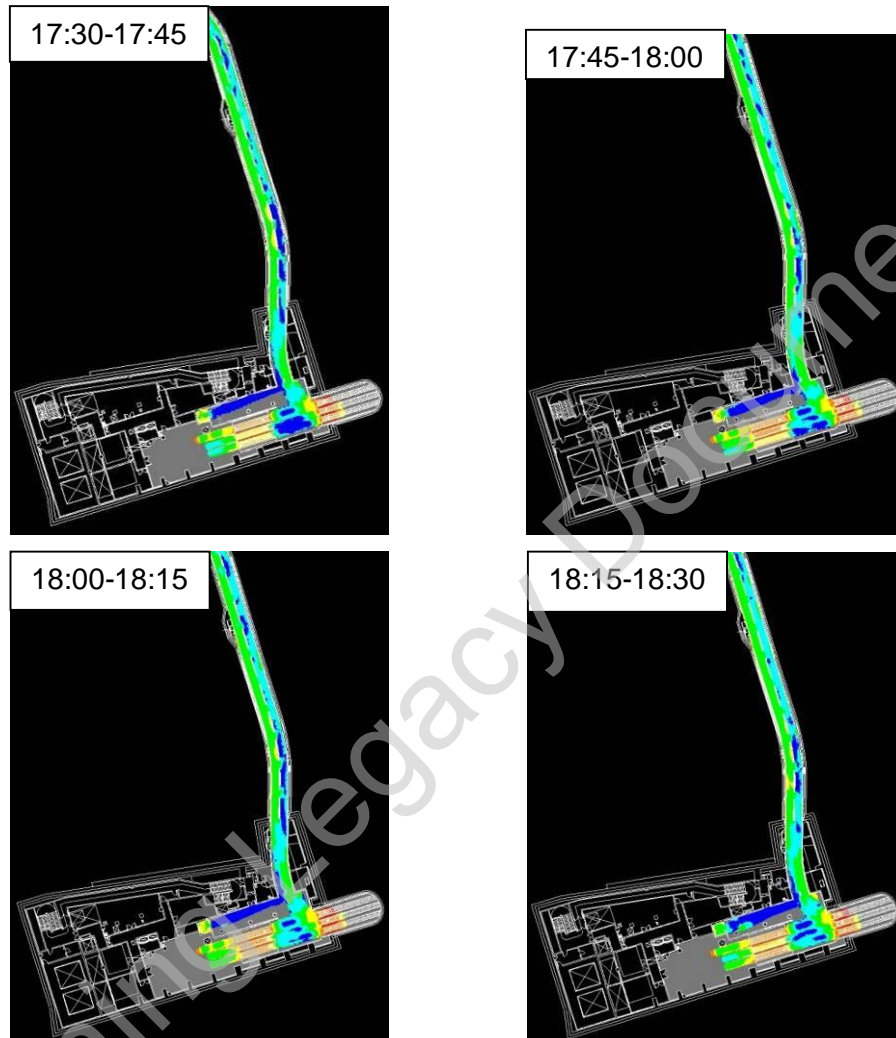


The figures above show that the Intermediate level is compliant in a 2026+7% scenario.

**PM 2026+14%**

Figure 5.6 illustrates the PM peak 2026+14% walking level of service results for the Intermediate level.

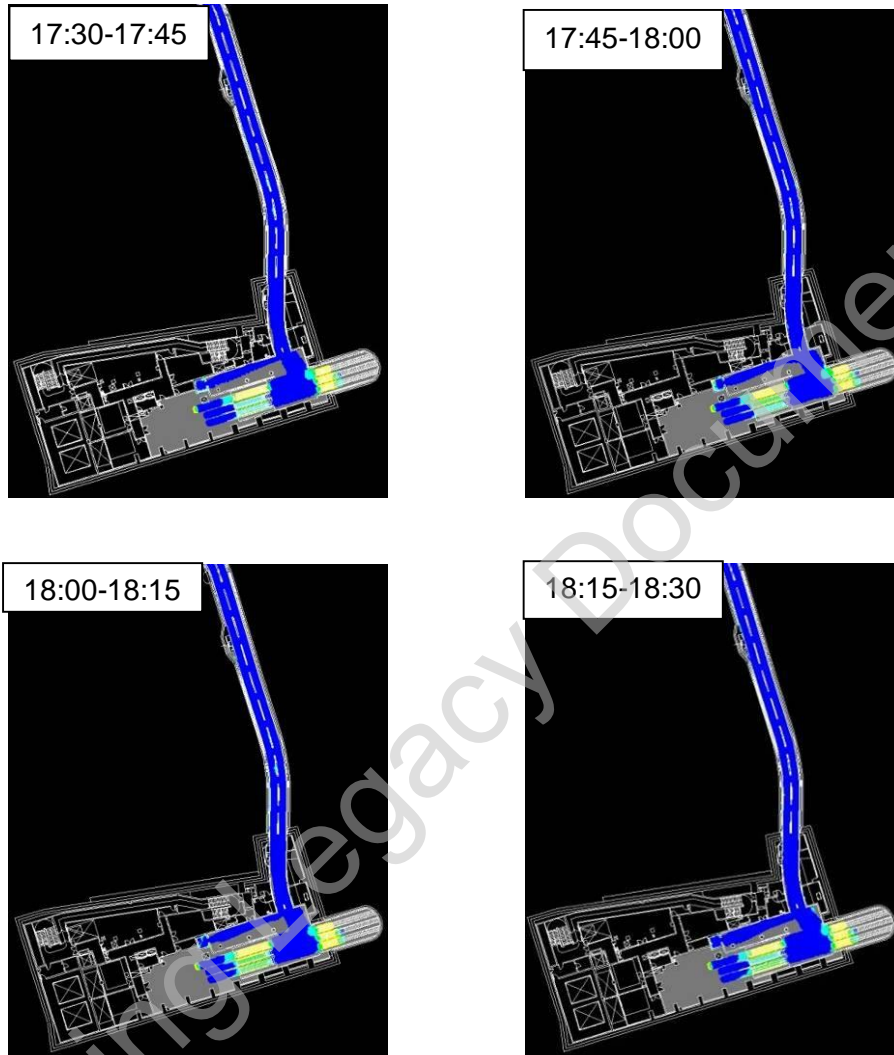
**Figure 5.3 – PM Peak 2026+14% Intermediate Level Walking Level of Service**



The figure above shows that the Intermediate level is compliant in a 2026+14% scenario.

Figure 5.4 illustrates the PM peak 2026+14% queuing level of service results for the Intermediate level.

**Figure 5.4 – PM Peak 2026+14% Intermediate Level Queuing Level of Service**

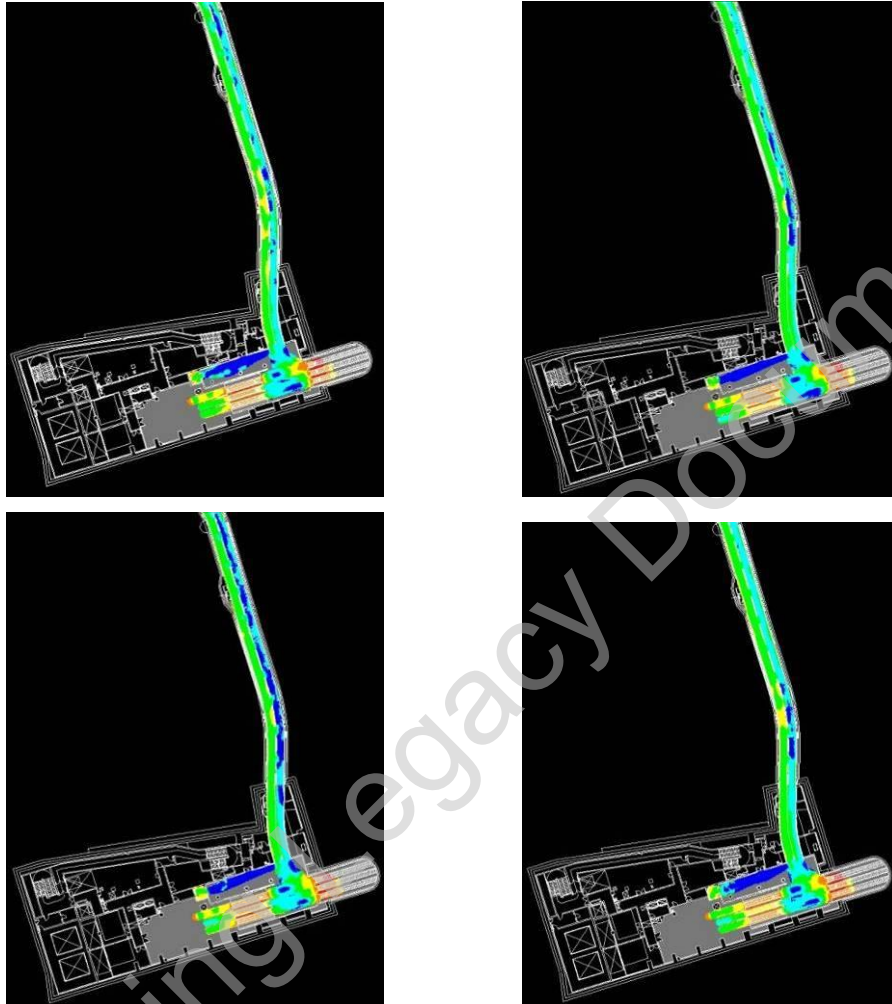


The figure above shows that the Intermediate level is compliant in a 2026+14% scenario.

**PM 2026+21%**

Figure 5.5 illustrates the PM peak 2026+21% walking level of service results for the Intermediate level.

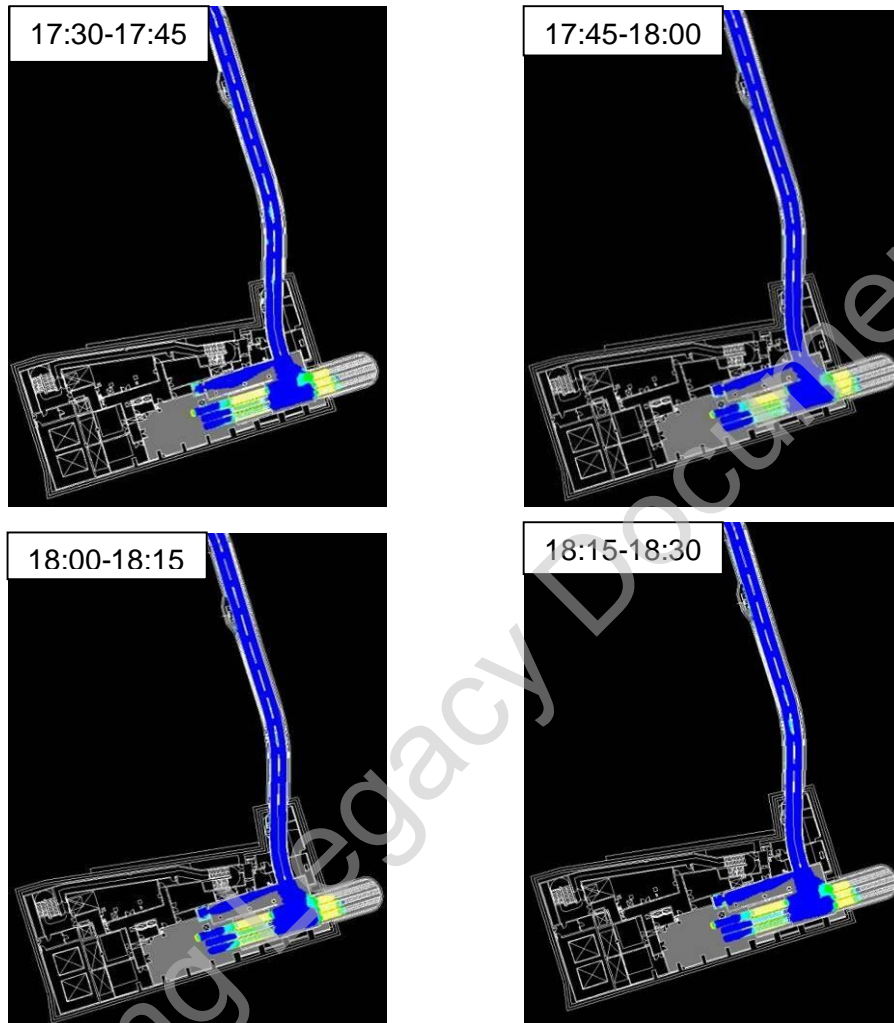
**Figure 5.5 – PM Peak 2026+21% Intermediate Level Walking Level of Service**



The figure above shows that the Intermediate level is compliant in a 2026+21% scenario

Figure 5.6 illustrates the PM peak 2026+21% queuing level of service results for the Intermediate level.

**Figure 5.6 – PM Peak 2026+21% Intermediate Level Queuing Level of Service**



The figure above shows that the Intermediate level is compliant in a 2026+21% scenario. This indicates that the breakpoint occurs at the Intermediate level between 2026+21% and 2026+28%. It was agreed with LU and CRL that further analysis to find out where the breakpoint is between +21% and +28% was not required.

### PM 2026+28% Intermediate Level Mitigation

It is proposed that in a 2026+28% scenario the use of the fire stairs for pedestrians travelling from the LU tunnel to platform level will be used to relieve the pedestrian density at the Intermediate level. The pedestrians completing this movement in 2026+28% are:

- LU to CR Eastbound Platform 2304 pedestrians
- LU to CR Westbound Platform 1344 pedestrians
- Total demand 3648 pedestrians

In the Stage E CAD drawing the stairs are 2m wide and the peak 5 minute demand is 157 pedestrians. With this demand, assuming all pedestrian demand from LU to CR use the stairs, there would be 29ppm which falls within LoS C (stairway Level of service).

Therefore the stairs can accommodate Non PRM pedestrians travelling from LU to Crossrail which, if required, would alleviate the Intermediate level non-compliance. This would allow the pedestrians travelling down the escalator from Davies Street, which has a maximum flow rate of 90ppm in the PM peak 2026+28% scenario, to walk directly to the escalators to platform level without any queuing occurring. Appendix N presents the pedestrian modelling results when the fire escape stairs are used.

The escape stairs provide the passive mitigation required by CPFR. Upgrade of the stairs for regular passenger use would be provided when required (which is after 2026 +21%), not at the time of station opening.

To implement using the fire escape stairs as a form of mitigation the following would be required:

#### LEVEL -3

- Introduction of magnetic doors within corridor at Level -2 to control movement of people during access to platform concourse and release during emergency evacuation
- Revise specification of finishes to comply with LU standards requirement for public stairs
- Revise Lighting to comply with public spaces requirement
- Revise CCTV and PA VA coverage
- Additional Wayfinding and Signage required
- Potential Head Height non-compliance against SPSP requirement for public areas

#### LEVEL -4

- Introduction of magnetic doors to control movement of people and avoid access to back of house areas
- Revise specification of finishes to comply with LU standards requirement for public stairs
- Revise Lighting to comply with public spaces requirement
- Revise CCTV and PA VA coverage
- Additional Wayfinding and Signage required

- Potential Head Height non-compliance against SPSG requirement for public areas

#### **LEVEL -5**

- Introduction of magnetic doors to control movement of people and avoid access to back of house areas
- Revise specification of finishes to comply with LU standards requirement for public stairs
- Revise Lighting to comply with public spaces requirement
- Revise CCTV and PA VA coverage
- Additional Wayfinding and Signage required
- Potential Head Height non-compliance against SPSG requirement for public areas

All the above would need to be covered by a new scope of works for C132.

It is important to note that this mitigation measure does not affect the fire strategy.

#### **5.1.3 Platform Level Results**

This section of the report displays the PM 2026 results for +7%, +14% and +21% for the Platform level for queuing and walking level of service.



**PM 2026+7%**

Figure 5.1 illustrates the PM peak 2026+7% walking level of service results on the Platform level.

**Figure 5.7 – PM Peak 2026+7% Platform Level Walking Level of Service**

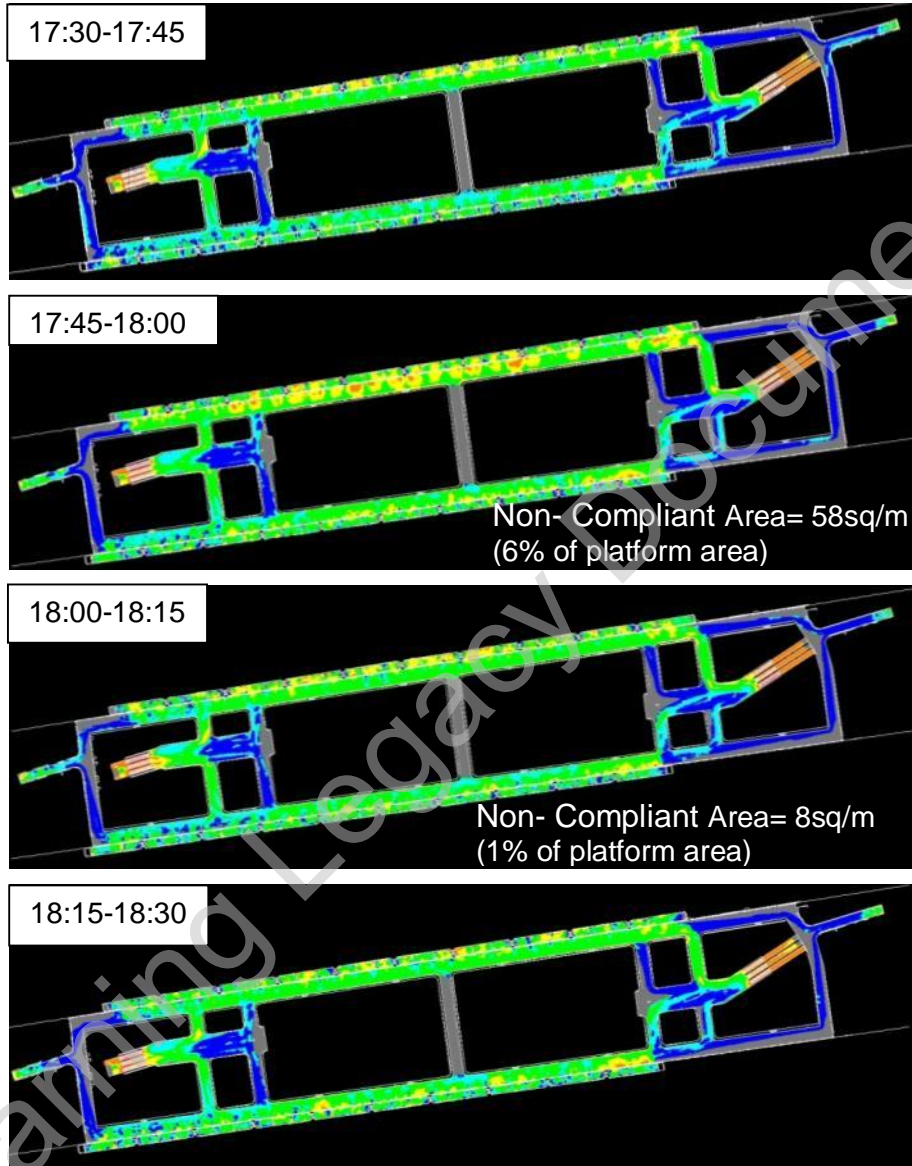


The figures above show that the Platform level is only non-compliant for a very small area of the platform in a 2026+7% scenario.

**PM 2026+14%**

Figure 5.6 illustrates the PM peak 2026+14% walking level of service results for the Platform level.

**Figure 5.8 – PM Peak 2026+14% Platform Level Walking Level of Service**



The figures above show that the Platform level is non-compliant for 6% of the platform area during the peak 15 minutes in the PM 2026 +14% scenario and has been identified in consultation with LU and CRL as the break point for the platform level.

**PM 2026+21%**

Figure 5.5 illustrates the PM peak 2026+21% walking level of service results for the Platform level.

**Figure 5.9 – PM Peak 2026+21% Platform Level Walking Level of Service**



The figures above show that the Platform level is non-compliant with a significant proportion, 11% of the platform area not meeting Crossrail guidance during the peak 15 minutes in the PM 2026+21% scenario.

**PM 2026+28% Platform Level Mitigation**

The proposed mitigation to improve the level of service on the platforms would be for a station member of staff to make announcements on the platform for passengers to move along the platform to spread people out along the platform length.

## 6 Summary

### 6.1.1 Conclusions

Overall the Stage E Design meets Crossrail criteria for AM and PM 2026 and 2026+28%, with the exception of the Intermediate and platform level during the PM peak 2026+28% scenario. In this scenario, walking LoS F and queuing LoS D is experienced at the intermediate level, this is caused by the queue at the top of the down escalator towards the platform. At platform level, walking LoS E and LoS D is experience at the edge and the back of the eastbound platform respectively; this is caused by queuing passenger for the eastbound trains. Walking level of service D also occurs in the cross passageway on the westbound platform to the Davies Street escalators in the AM 2026 and 2026+28% scenarios. This has occurred as a result of the coding within the pedestrian model. C132 are of the view that this issue would not occur in reality and that with signs on the westbound platform to direct pedestrians to use the cross passageway further away from the escalators this would not occur.

The results of the breakpoint modelling indicate that this deterioration in level of service occurs between 2026+21% and 2026+28% at the Intermediate level and between 2026+7% and 2026+14% at platform level. To mitigate against these level of services in the PM peak 2026+28% scenario it is recommended that the fire escape stairs from the Intermediate level to platform level are used by pedestrians travelling from LU services and that announcements are made at platform level to encourage passengers to move along the platform.



**Appendix A – AM Peak 2026 Cover Sheet**

Learning Legacy Document

<u>List of Input Assumptions</u>	<u>CRL</u>	<u>LU</u>
1. CAD (Extent of Model)	Y	Y
2. TPH	Y	Y
3. Escalator Config.		
4. Gateline Config.		
5. Ticketing		
6. PRM Routings and Rules		
7. Non-PRM Routings		
8. One-Way System Elements		
9. CRL Adit Usage	Y	Y
10. CRL Timetable	Y	Y
11. CRL Cancelled Train Logic		
12. LU Timetable		
13. NR / Other Timetable		
14. Constraining Alighters Logic	Y	Y
15. Constraining Boarders Logic		
16. Boarding Profiles (CRL)	Y	Y
17. Boarding Profiles (LU / Other)		
18. Alighting Profiles (CRL)	Y	Y
19. Alighting Profiles (LU / Other)		
20. Boarding Logic	Y	Y
21. Dwell Time Logic	Y	Y
22. 15 Minute Profiling	Y	Y
23. TPH broken up into 15 minute periods	Y	Y
24. 15 Minute Demand to Train Services	Y	Y
25. B & A Percentages	Y	Y
26. Accuracy of Seams		

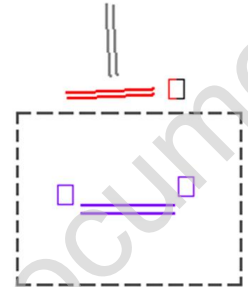
## Version Control for 'ACS Bond Street CRL Complex (2026AM)'

Version Number	Date	Comments/Changes	Submitted by	Model Builder File Name (if applicable)
v1.0	20/05/2010	<b>Sent from Robert Duff (LU) to Nick Gavrielides (CRL) to be passed on to each respective Framework Consultant.</b> Assumption 4: Ticketing is still outstanding (FDC's informed to proceed with whatever's in their current model), Assumption 11: Cancelled Train Logic is to be determined when the perfect timetable set-up spreadsheets are sent back to CRL by the FDC, Assumption 15: In line with the Cancelled Train timetable amendments due to be undertaken by CRL, a Step by Step Boarding Constraint Guide still needs to be completed by CRL. The Train Load Percentages in Assumption 25 will need to be filled in once the correct cancelled train has been determined.	Robert Duff (LU)	N/A
v1.1	12/07/2010	Correction to tab 24, cells CU14 and CU21.	Nick Gavrielides	N/A
v1.1	18/08/2010	Correction to tab 1, cell BX37, Train capacity changed from 1500 to 1700	Victoria Ng	N/A
v2	06/10/2010	Sent from C132 to Crossrail pedestrian modelling team	Christine Palmer (WSP)	Bond St AM Sept 2010 For Report.LGM
v3	22/11/2010	A meeting between LUL, C132 and Crossrail on 10th November 2010 was held to discuss the issues highlighted in the model audit. Following this meeting a list of actions was completed by LUL for C132 to incorporate into the models.	Christine Palmer (WSP)	Bond St AM 2026 Nov 2010 For Report.LGM
v4	26/07/2011	Following the November Audit the following changes have been made to the Cover sheet: CAD Updated to Stage E CAD for Davies Street and Intermediate Level ( <b>see sheet 1</b> ) Increased number of ticket gates at Davies Street and Hanover Square ( <b>see sheet 4</b> ) Non PRM's now can use WAG's at Hanover Square ( <b>see sheet 6</b> ) Eastbound train stopping position moved westwards and revised boarding profiles issued by Crossrail on 18/04/11 used ( <b>see sheet 16</b> ) Revised Bond Street PM Peak demand added into the <b>BDS 2026 Demand worksheet</b>	Christine Palmer (WSP)	Bond St AM 2026_Issued July 2011.LGM
v5	19/08/2011	Finalised for Issue with Final Report - updated train position diagram added to sheet 3. Revised reference to CPFR on sheet 2 from CPFR 4 to 5.	Christine Palmer (WSP)	Bond St AM 2026_Issued August 2011.LGM

List of Input Assumptions

CRL	LUL
Y	Y
Y	Y
Y	Y
Y	Y
Y	Y
Y	Y
Y	Y
Y	Y
Y	Y
Y	Y
Y	Y

INPUT 1: CAD (Extent of Model)



Ticket Halls:

	Existing?	New?
Davies Street CRL Ticket Hall		Y
Hanover Square CRL Ticket Hall		Y

Platforms:

	Existing?	New?
CRL WB		Y
CRL EB		Y

Outside Extent of Model but accurate flows captured?:

**Yes demand profile from LUL's Legion model to Bond Street Crossrail has been adopted.**

(Please see #26 for further details)

Source of CAD:

Drawing Number Davies Street Ticket Hall	C132-WSP-A-DDA-C125-01100.dwg
Drawing Number Hanover Square Ticket Hall	C132-WSP-A-DDA-C125-52101.dwg
Drawing Number Intermediate Level	C132-WSP-A-DDA-C125-01120.dwg
Drawing Number LUL Passageway Link	C132-WSP-A-DMA-C125-03130.dwg
Drawing Number Platform Level	C132-WSP-A-DMA-C125-03150.dwg
Drawing Number Passageway to Western lifts	C132-WSP-A-DMA-C125-01150.dwg
Drawing Number Passageway to Eastern lifts	C132-WSP-A-DMA-C125-02150.dwg

Rolling Stock CAD:

	Total Number of Carriages	Configuration	T: No. of Doors	DM: No. of Doors	UNDM: No. of Doors	Assumed Capacity
CRL	10	DM-T-T-T-T-T-T-T-T-DM	3D	2D	-	1700 <sup>a</sup>

References:

- (a) As stated in CPFR v4.0
- CRL Rolling Stock: D = 1600mm

Key CRL Platform Dimensions:

CRL WB Platform Width	4.5m
CRL EB Platform Width	4.5m

(N.B. Usable Width (from PED to when backwall height reaches 2.4m))

(N.B. Usable Width (from PED to when backwall height reaches 2.4m))



List of Input Assumptions

CRL LU

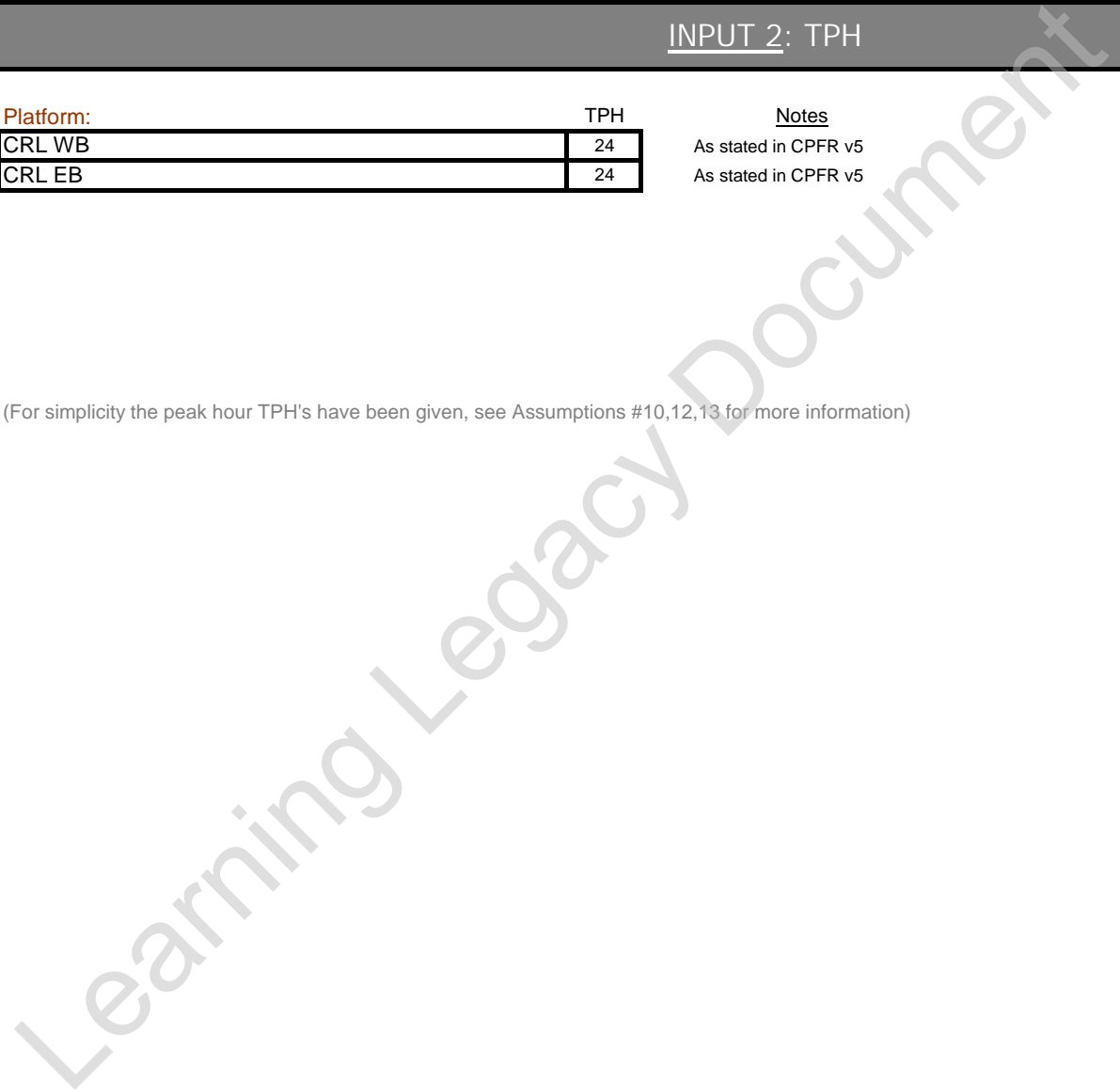
INPUT 2: TPH

1. CAD (Extent of Model)	Y	Y
2. TPH	Y	Y
3. Escalator Config.		
4. Gateline Config.		
5. Ticketing		
6. PRM Routings and Rules		
7. Non-PRM Routings		
8. One-Way System Elements		
9. CRL Adit Usage	Y	Y
10. CRL Timetable	Y	Y
11. CRL Cancelled Train Logic		
12. LU Timetable		
13. NR / Other Timetable		
14. Constraining Alighters Logic	Y	Y
15. Constraining Boarders Logic		
16. Boarding Profiles (CRL)	Y	Y
17. Boarding Profiles (LU / Other)		
18. Alighting Profiles (CRL)	Y	Y
19. Alighting Profiles (LU / Other)		
20. Boarding Logic	Y	Y
21. Dwell Time Logic	Y	Y
22. 15 Minute Profiling	Y	Y
23. TPH broken up into 15 minute periods	Y	Y
24. 15 Minute Demand to Train Services	Y	Y
25. B & A Percentages	Y	Y
26. Accuracy of Seams		

Platform:	TPH
CRL WB	24
CRL EB	24

Notes  
As stated in CPFR v5  
As stated in CPFR v5

(For simplicity the peak hour TPH's have been given, see Assumptions #10,12,13 for more information)



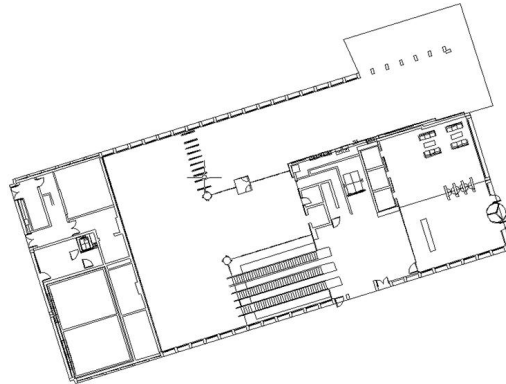


List of Input Assumptions	CRL	LU
---------------------------	-----	----

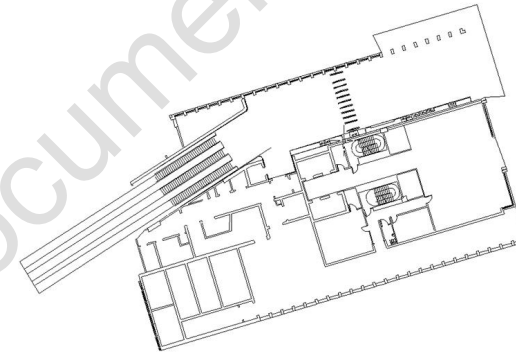
1. CAD (Extent of Model)	Y	Y
2. TPH	Y	Y
3. Escalator Config.	Y	
4. Gateline Config.	Y	
5. Ticketing		
6. PRM Routings and Rules	Y	
7. Non-PRM Routings	Y	
8. One-Way System Elements	Y	
9. CRL Adit Usage	Y	Y
10. CRL Timetable	Y	Y
11. CRL Cancelled Train Logic	Y	Y
12. LU Timetable		
13. NR / Other Timetable		
14. Constraining Alighters Logic	Y	Y
15. Constraining Boarders Logic	Y	Y
16. Boarding Profiles (CRL)	Y	Y
17. Boarding Profiles (LU / Other)		
18. Alighting Profiles (CRL)	Y	Y
19. Alighting Profiles (LU / Other)		
20. Boarding Logic	Y	Y
21. Dwell Time Logic	Y	Y
22. 15 Minute Profiling	Y	Y
23. TPH broken up into 15 minute periods	Y	Y
24. 15 Minute Demand to Train Services	Y	Y
25. B & A Percentages	Y	Y
26. Accuracy of Seams	Y	

INPUT 4: Gateline Configurations

Davies Street CRL Ticket Hall



Hanover Square CRL Ticket Hall



Davies Street

No. Inwards UTS Gates	1
No. Outwards UTS Gate	6
	<u>7</u>
No. Inwards WAGS	1
No. Outwards WAGS	1
No. Bi-Directional WAGS	0
	<u>2</u>

Hanover Square

No. Inwards UTS Gates	1
No. Outwards UTS Gate	7
	<u>8</u>
No. Inwards WAGS	1
No. Outwards WAGS	1
No. Bi-Directional WAGS	0
	<u>2</u>

Ticket capacity 33 pax/,min or 1.8 sec delay (taken from LUL Station Modelling with LEGION Best Practice Guide)

Ticket capacity 25 pax/,min or 2.4 sec delay - as per text below

(\*) There is the requirement that on any single gateline there should be two uni-directional WAGS positioned at either side of the gateline  
Bi-Directional WAGS are not favourable since they provide a throughput of just 7 pax/min compared to 25 pax/min of their uni-directional counterparts.

(\*\*) For any new ticket hall, the adequacy of the number of gates (proposed or current) should be backed up using the SPSG Gateline Formula.

List of Input Assumptions

INPUT 5: Ticketing

1. CAD (Extent of Model)	Y	Y
2. TPH	Y	Y
3. Escalator Config.	Y	
4. Gateline Config.	Y	
5. Ticketing		
6. PRM Routings and Rules	Y	
7. Non-PRM Routings	Y	
8. One-Way System Elements	Y	
9. CRL Adit Usage	Y	Y
10. CRL Timetable	Y	Y
11. CRL Cancelled Train Logic	Y	Y
12. LU Timetable		
13. NR / Other Timetable		
14. Constraining Alighters Logic	Y	Y
15. Constraining Boarders Logic	Y	Y
16. Boarding Profiles (CRL)	Y	Y
17. Boarding Profiles (LU / Other)		
18. Alighting Profiles (CRL)	Y	Y
19. Alighting Profiles (LU / Other)		
20. Boarding Logic	Y	Y
21. Dwell Time Logic	Y	Y
22. 15 Minute Profiling	Y	Y
23. TPH broken up into 15 minute periods	Y	Y
24. 15 Minute Demand to Train Services	Y	Y
25. B & A Percentages	Y	Y
26. Accuracy of Seams	Y	Y

Davies Street CRL Ticket Hall:

Number of CRL TVM POM's  Transaction Time assumed:   
 Number of CRL TOP POM's  Transaction Time assumed:   
 % of accessing CRL/LU passengers that are assumed to require CRL POM's

Hanover Square CRL Ticket Hall:

Number of CRL TVM POM's  Transaction Time assumed:   
 Number of CRL TOP POM's  Transaction Time assumed:   
 % of accessing CRL/LU passengers that are assumed to require CRL POM's

LU LBPG

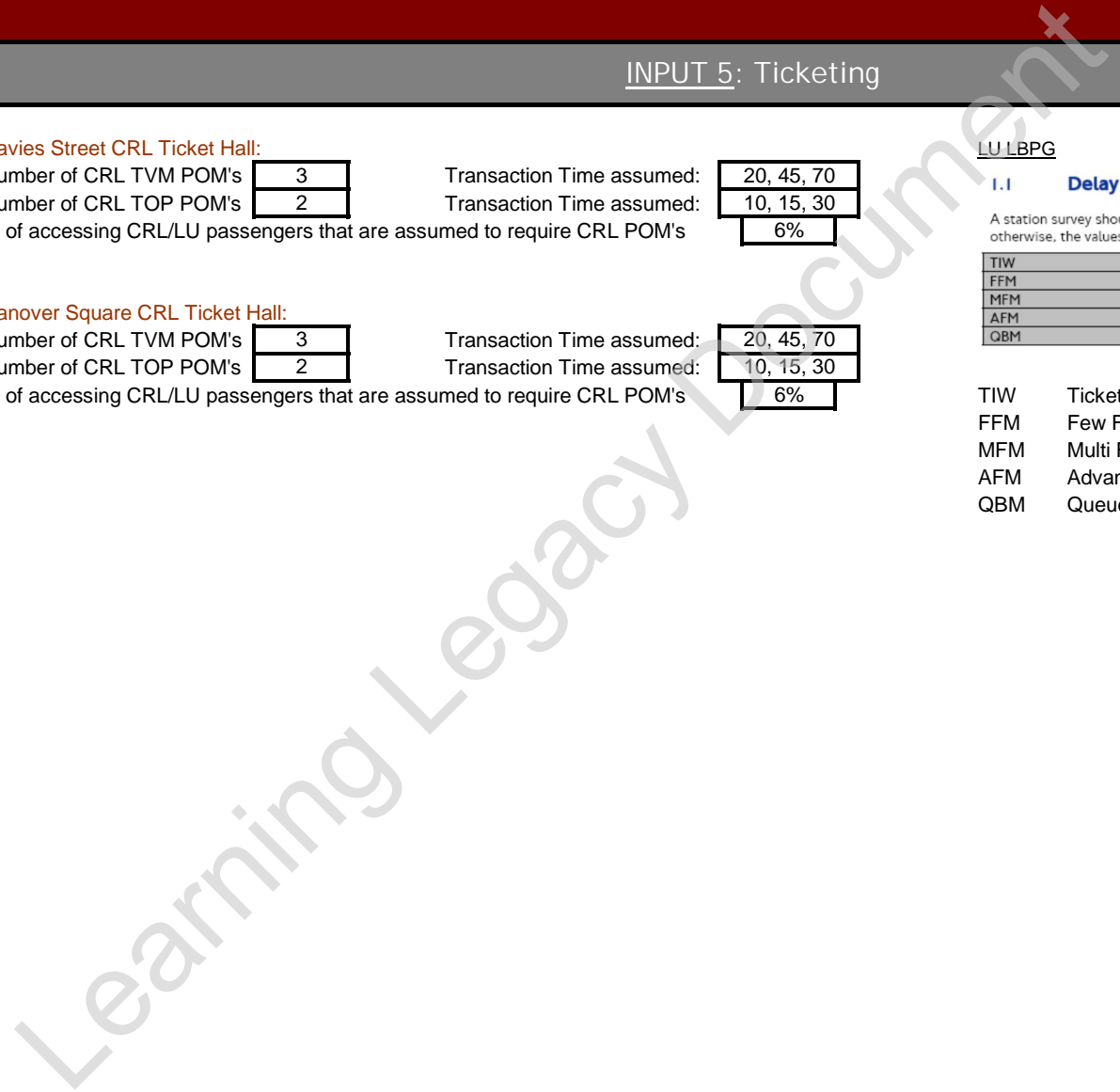
1.1 Delay used on ticket issuing facilities

A station survey should be conducted to collect the relevant information; otherwise, the values below may be used. All figures in seconds.

TIW	Variable: 20 (min), 40 (mean), 90 (max)
FFM	10, 15, 30
MFM	20, 45, 70
AFM	15, 20, 30
QBM	15, 40, 70

Source: LU LBPG (July 2009, Vol 3. Pg 1)

TIW Ticket Issuing Window  
 FFM Few Far Machine  
 MFM Multi Fare Machine  
 AFM Advanced Fare Machine  
 QBM Queue Buster Machine



**Band Street CRL Complex - 200 Year Storm - 10/1/14**

**INPUT 6: PRM Routing and Rules**

**Methodology:**

1. CRL General Rules
2. The
3. General Config
4. General Config
5. Training
6. PRM Routing and Rules
7. northbound
8. One Way System Estimation
9. CRL and Range
10. CRL Direction
11. CRL Carrieway Lane Logic
12. U/L Turnouts
13. M/L Other Roadside
14. Connecting Highway Logic
15. Connecting Highway Logic
16. Bearing Profile CRL
17. Bearing Profile CRL (Other)
18. Bearing Profile CRL (Other)
19. Bearing Logic
20. Coast Time Logic
21. M/L Match Finding
22. Through up and to other points
23. Match Down to other points
24. B & A Perceptions
25. Accuracy of Events

**WAG Rules:**

The following PRMs get sent through the WAG:

PRM A	Y
PRM B	Y
PRM C	Y
PRM D	Y
PRM E	Y
PRM F	Y
PRM G	Y
PRM H	Y
PRM I	Y
PRM J	Y
PRM K	Y
PRM L	Y
PRM M	Y
PRM N	Y
PRM O	Y
PRM P	Y
PRM Q	Y
PRM R	Y
PRM S	Y
PRM T	Y
PRM U	Y
PRM V	Y
PRM W	Y
PRM X	Y
PRM Y	Y
PRM Z	Y

**U/L Rules:**

The following PRMs get sent to the U/L:

PRM A	Y
PRM B	Y
PRM C	Y
PRM D	Y
PRM E	Y
PRM F	Y
PRM G	Y
PRM H	Y
PRM I	Y
PRM J	Y
PRM K	Y
PRM L	Y
PRM M	Y
PRM N	Y
PRM O	Y
PRM P	Y
PRM Q	Y
PRM R	Y
PRM S	Y
PRM T	Y
PRM U	Y
PRM V	Y
PRM W	Y
PRM X	Y
PRM Y	Y
PRM Z	Y

**Scale and Size:**

Type	Channel	Scale	Method
PRM A	Small	1:5000	Point
PRM B	Small	1:5000	Point
PRM C	Medium	1:1000	Normal Distribution
PRM D	Large	1:500	Normal Distribution
PRM E	Large	1:500	Normal Distribution

**Routing Diagrams:**

- Davies Street to Crossrail Westbound
- Harover Square to Crossrail Westbound
- Davies Street to Crossrail Eastbound
- Harover Square to Crossrail Eastbound
- U/L Services to Crossrail Eastbound
- U/L Services to Crossrail Westbound
- Crossrail Eastbound - Davies Street
- Crossrail Eastbound - Harover Square
- Crossrail Eastbound - U/L Services
- Crossrail Westbound - Davies Street
- Crossrail Westbound - Harover Square
- Crossrail Westbound - U/L Services

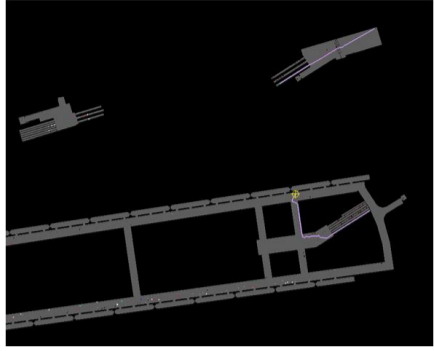
Learning Legacy Document

List of Input Assumptions

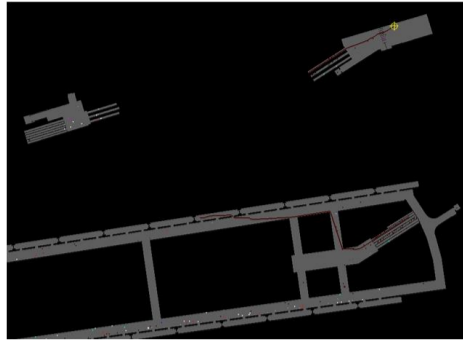
	CRL	LU
1. CAD (Extent of Model)	Y	Y
2. TPH	Y	Y
3. Escalator Config.		
4. Gate/line Config.		
5. Ticketing		
6. PRM Routings and Rules		
7. Non-PRM Routings		
8. One-Way System Elements		
9. CRL Adit Usage	Y	Y
10. CRL Timetable	Y	Y
11. CRL Cancelled Train Logic		
12. LU Timetable		
13. NR / Other Timetable		
14. Constraining Alighters Logic	Y	Y
15. Constraining Boarders Logic		
16. Boarding Profiles (CRL)	Y	Y
17. Boarding Profiles (LU / Other)		
18. Alighting Profiles (CRL)	Y	Y
19. Alighting Profiles (LU / Other)		
20. Boarding Logic	Y	Y
21. Dwell Time Logic	Y	Y
22. 15 Minute Profiling	Y	Y
23. TPH broken up into 15 minute periods	Y	Y
24. 15 Minute Demand to Train Services	Y	Y
25. B & A Percentages	Y	Y
26. Accuracy of Seams		

INPUT 7: Non-PRM Routings

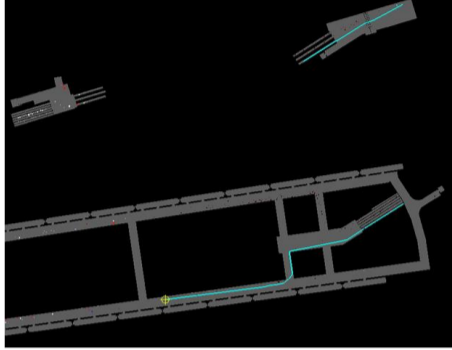
HS -> CRL EB:



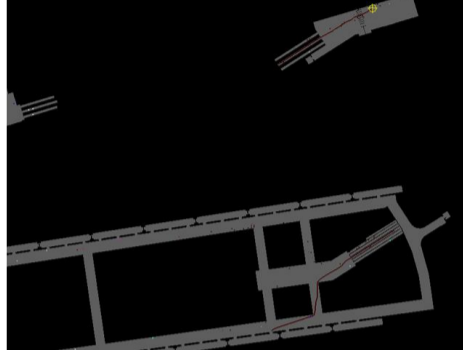
CRL EB -> HS:



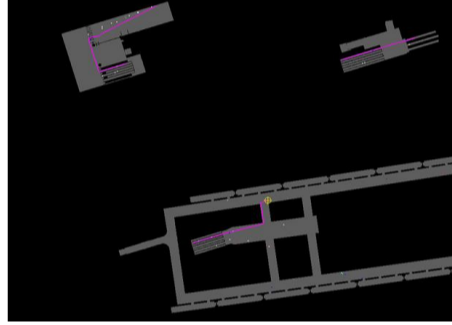
HS -> CRL WB:



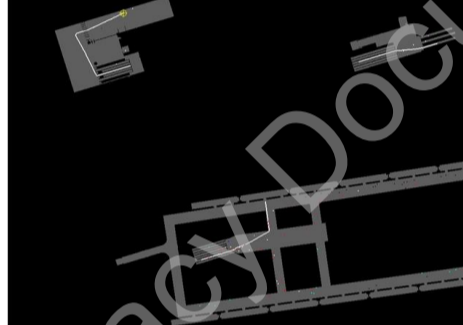
CRL WB -> HS:



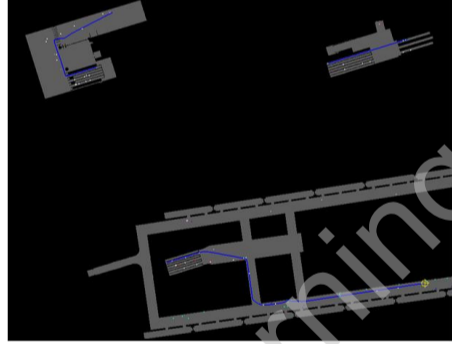
DS -> CRL EB:



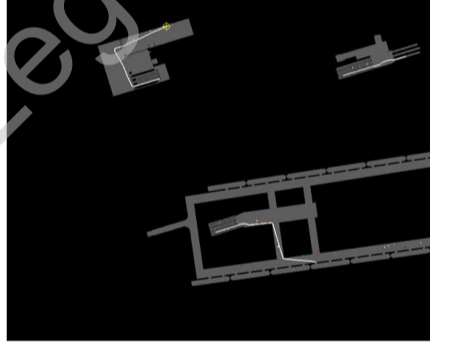
CRL EB -> DS:



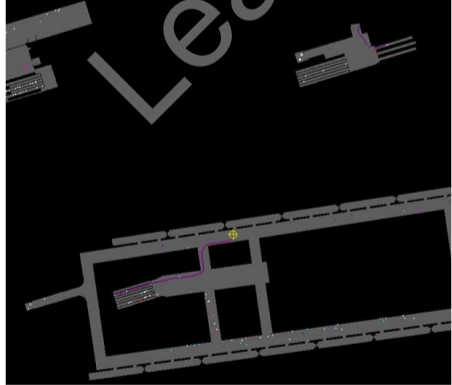
DS -> CRL WB:



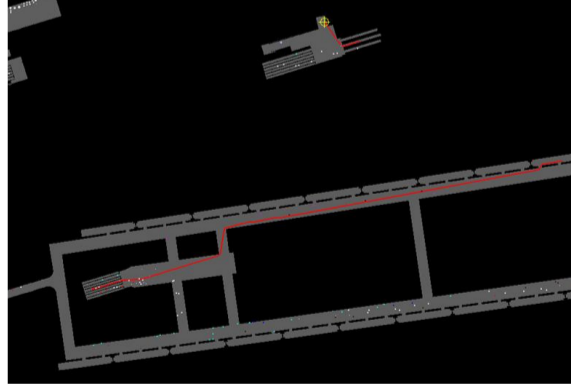
CRL WB -> DS:



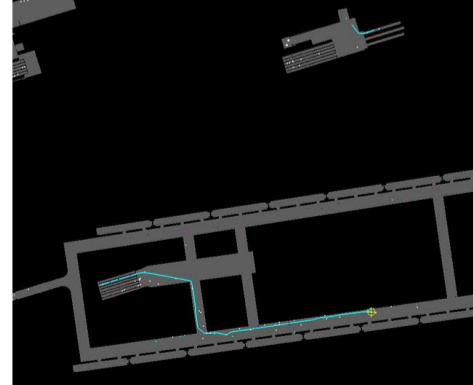
LUL -> CRL EB:



CRL EB -> LUL:



LUL -> CRL WB:



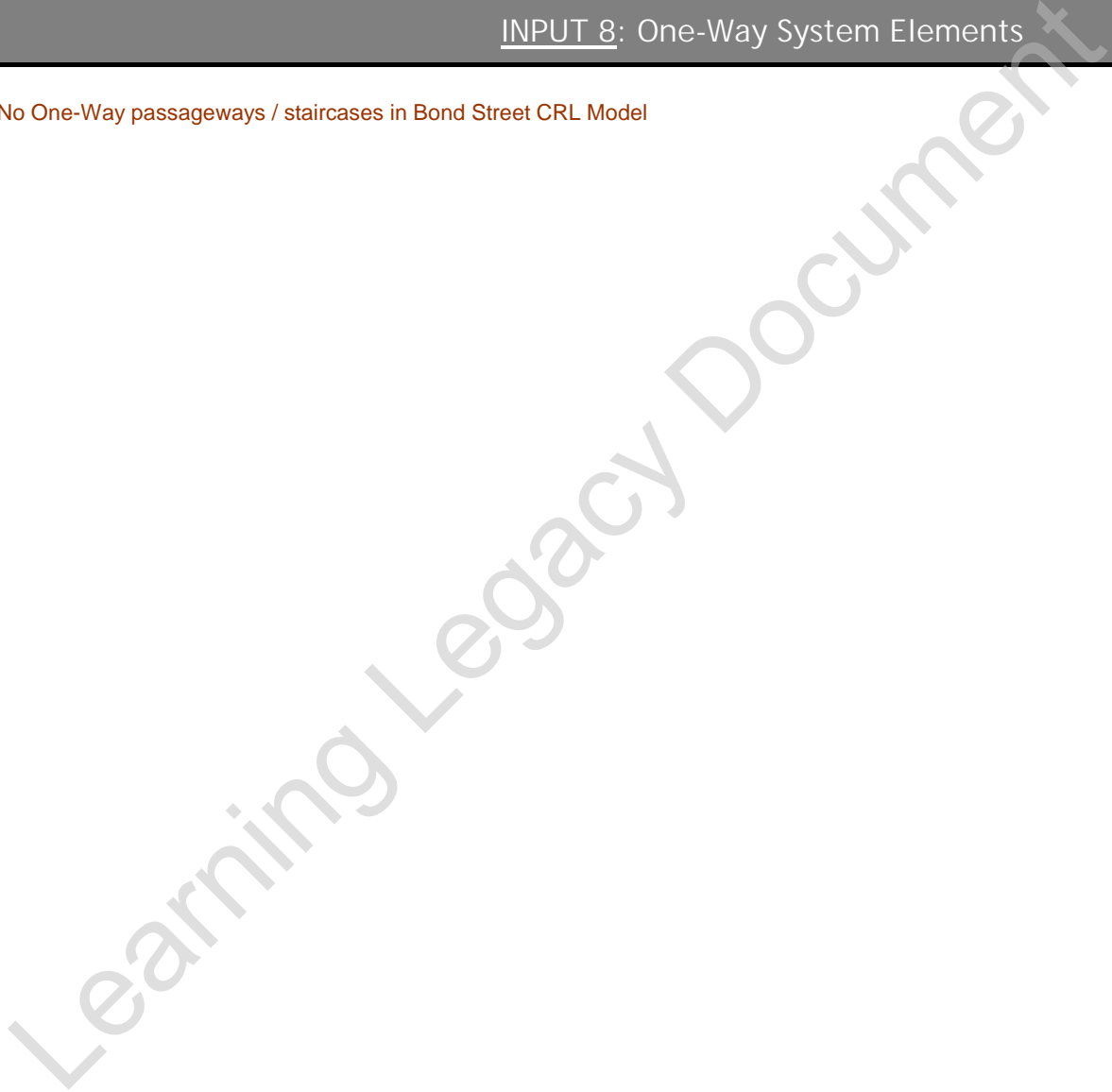
CRL WB -> LUL:



INPUT 8: One-Way System Elements

List of Input Assumptions	CRL	LU
1. CAD (Extent of Model)	Y	Y
2. TPH	Y	Y
3. Escalator Config.		
4. Gateline Config.		
5. Ticketing		
6. PRM Routings and Rules		
7. Non-PRM Routings		
8. One-Way System Elements		
9. CRL Adit Usage	Y	Y
10. CRL Timetable	Y	Y
11. CRL Cancelled Train Logic		
12. LU Timetable		
13. NR / Other Timetable		
14. Constraining Alighters Logic	Y	Y
15. Constraining Boarders Logic		
16. Boarding Profiles (CRL)	Y	Y
17. Boarding Profiles (LU / Other)		
18. Alighting Profiles (CRL)	Y	Y
19. Alighting Profiles (LU / Other)		
20. Boarding Logic	Y	Y
21. Dwell Time Logic	Y	Y
22. 15 Minute Profiling	Y	Y
23. TPH broken up into 15 minute periods	Y	Y
24. 15 Minute Demand to Train Services	Y	Y
25. B & A Percentages	Y	Y
26. Accuracy of Seams		

No One-Way passageways / staircases in Bond Street CRL Model



List of Input Assumptions

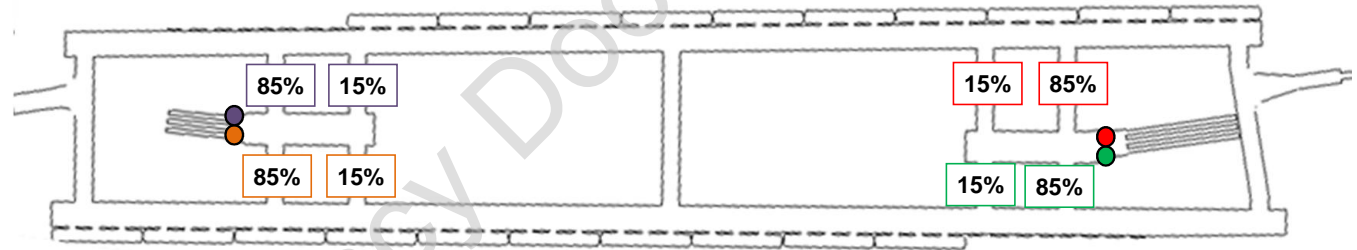
CRL	LU
Y	Y
Y	Y
Y	Y
Y	Y
Y	Y
Y	Y
Y	Y
Y	Y
Y	Y
Y	Y
Y	Y
If	Y
Y	Y
Y	Y
Y	Y

1. CAD (Extent of Model)
2. TPH
3. Escalator Config.
4. Gateline Config.
5. Ticketing
6. PRM Routings and Rules
7. Non-PRM Routings
8. One-Way System Elements
9. CRL Adit Usage
10. CRL Timetable
11. CRL Cancelled Train Logic
12. LU Timetable
13. NR / Other Timetable
14. Constraining Alighters Logic
15. Constraining Boarders Logic
16. Boarding Profiles (CRL)
17. Boarding Profiles (LU / Other)
18. Alighting Profiles (CRL)
19. Alighting Profiles (LU / Other)
20. Boarding Logic
21. Dwell Time Logic
22. 15 Minute Profiling
23. TPH broken up into 15 minute periods
24. 15 Minute Demand to Train Services
25. B & A Percentages
26. Accuracy of Seams

INPUT 9: CRL Adit Usage

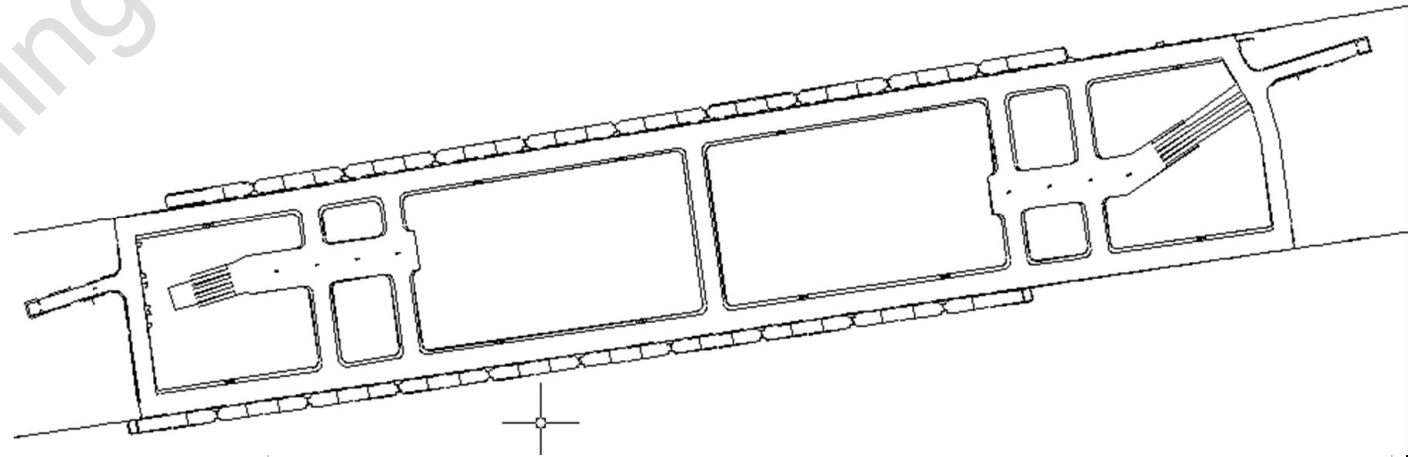
Boarders:

Strict % split assumption as detailed in below diagram.  
Specific Rules will exist for certain types of PRM's (see Assumption #6 for more information)



Alighters:

Logic Rule: Passengers as soon as they step off the train aim for the lower escalator concourse on the western/eastern end of the platforms and apply 'Shortest Distance' logic to determine the adit to be used. If this leads to unrealistic crowding in one adit while leaving the next adit along under-utilised, a reassignment to the less utilised adit would be appropriate.  
Certain Rules will exist for certain types of PRM's (see Assumption #6 for more information).





List of Input Assumptions

CRL LU

INPUT 10: CRL Timetable

1. CAD (Extent of Model)	Y	Y
2. TPH	Y	Y
3. Escalator Config.		
4. Gateline Config.		
5. Ticketing		
6. PRM Routings and Rules		
7. Non-PRM Routings		
8. One-Way System Elements		
9. CRL Adit Usage	Y	Y
10. CRL Timetable	Y	Y
11. CRL Cancelled Train Logic		
12. LU Timetable		
13. NR / Other Timetable		
14. Constraining Alighters Logic	Y	Y
15. Constraining Boarders Logic		
16. Boarding Profiles (CRL)	Y	Y
17. Boarding Profiles (LU / Other)		
18. Alighting Profiles (CRL)	Y	Y
19. Alighting Profiles (LU / Other)		
20. Boarding Logic	Y	Y
21. Dwell Time Logic	Y	Y
22. 15 Minute Profiling	Y	Y
23. TPH broken up into 15 minute periods	Y	Y
24. 15 Minute Demand to Train Services	Y	Y
25. B & A Percentages	Y	Y
26. Accuracy of Seams		

CRL WB Platform - Descriptive Summary

Origin	TPH 7-8	TPH 8-9	TPH 9-10	Total 7-10
Shenfield	12	12	12	36
Abbey Wood	12	12	12	36
	24	24	24	72

Destination	TPH 7-8	TPH 8-9	TPH 9-10	Total 7-10
Paddington	14	14	14	42
Heathrow	4	4	4	12
West Drayton	2	2	2	6
Maidenhead	4	4	4	12
	24	24	24	72

CRL EB Platform - Descriptive Summary

Origin	TPH 7-8	TPH 8-9	TPH 9-10	Total 7-10
Paddington	14	14	14	42
Heathrow	4	4	4	12
West Drayton	2	2	2	6
Maidenhead	4	4	4	12
	24	24	24	72

Destination	TPH 7-8	TPH 8-9	TPH 9-10	Total 7-10
Shenfield	12	12	12	36
Abbey Wood	12	12	12	36
	24	24	24	72

List of Input Assumptions

CRL LU

- 1. CAD (Extent of Model) Y Y
- 2. TPH Y Y
- 3. Escalator Config. Y Y
- 4. Gateline Config. Y Y
- 5. Ticketing Y Y
- 6. PRM Routings and Rules Y Y
- 7. Non-PRM Routings Y Y
- 8. One-Way System Elements Y Y
- 9. CRL Adit Usage Y Y
- 10. CRL Timetable Y Y
- 11. CRL Cancelled Train Logic Y Y
- 12. LU Timetable Y Y
- 13. NR / Other Timetable Y Y
- 14. Constraining Alighters Logic Y Y
- 15. Constraining Boarders Logic Y Y
- 16. Boarding Profiles (CRL) Y Y
- 17. Boarding Profiles (LU / Other) Y Y
- 18. Alighting Profiles (CRL) Y Y
- 19. Alighting Profiles (LU / Other) Y Y
- 20. Boarding Logic Y Y
- 21. Dwell Time Logic Y Y
- 22. 15 Minute Profiling Y Y
- 23. TPH broken up into 15 minute periods Y Y
- 24. 15 Minute Demand to Train Services Y Y
- 25. B & A Percentages Y Y
- 26. Accuracy of Seams Y Y

INPUT 11: CRL Cancelled Train Logic

**CRL WB Platform - Descriptive Summary**

Origin	TPH 7-8	TPH 8-9	TPH 9-10	Total 7-10
Shenfield	12	11	12	35
Abbey Wood	12	12	12	36
	24	23	24	71

Destination	TPH 7-8	TPH 8-9	TPH 9-10	Total 7-10
Paddington	14	13	14	41
Heathrow	4	4	4	12
West Drayton	2	2	2	6
Maidenhead	4	4	4	12
	24	23	24	71

**CRL EB Platform - Descriptive Summary**

Origin	TPH 7-8	TPH 8-9	TPH 9-10	Total 7-10
Paddington	14	14	14	42
Heathrow	4	4	4	12
West Drayton	2	2	2	6
Maidenhead	4	4	4	12
	24	24	24	72

Destination	TPH 7-8	TPH 8-9	TPH 9-10	Total 7-10
Shenfield	12	12	12	36
Abbey Wood	12	12	12	36
	24	24	24	72

Cancellation Logic:

During the peak 15 minutes one train will be cancelled on one Crossrail platform. The train will be cancelled on the platform with the highest volume of passengers. If there are more alighters than boarders (usually the case in the AM peak) then the train with the most alighters will be cancelled, and similarly if there are more boarders than alighters (usually the case in the PM peak) then the train with the most popular destination will be cancelled.

In the cancelled train scenario, there will be more passengers than normal waiting on the platform and therefore more passengers trying to board the next train. In some cases it might therefore not be possible for all passengers to board the train following the cancelled train. The capacity will be assessed and boarders will be constrained so that capacity is not breached.

In the cancelled train scenario, there will also be more passengers alighting from subsequent trains. Generally the alighters that would have been on the cancelled train will be transferred onto the following trains travelling on the same route. For example, at Whitechapel if a westbound train from Shenfield is cancelled, the alighters that would have been on the cancelled train will be assumed to arrive on the following train from Shenfield. None of these passengers would arrive on trains from Abbey Wood as the line splits at Whitechapel. However, at stations further west, for example Bond Street, in the same situation the alighters from the cancelled train would arrive on the two following trains, some on the next train from Abbey Wood and some on the next train from Shenfield. This is because the passengers getting on between Whitechapel and Bond Street could come on the next train following the cancelled train, which would be from Abbey Wood, but passengers getting on east of Whitechapel would have to board the next train from Shenfield. The split between the two trains will be based on the general split from Shenfield and Abbey Wood.

In some cases, this approach would cause the number of alighters on the trains following the cancelled train to exceed capacity. This will be assessed and the number of alighters per train will be limited so as not to exceed the total capacity. For example, at Whitechapel if the cancelled train from Shenfield would have had 300 alighters, the initial calculation would put 600 alighters on the following train from Shenfield. However, if the percentage of the train load alighting at Whitechapel is 30% then the maximum possible number of alighters would be 30% of 1700 (max train load) = 510. Therefore, the train from Shenfield following the cancelled train would be limited to 510 alighters as opposed to 600. The excess of 90 would be transferred to the following train from Shenfield, i.e. two trains (from Shenfield) after the cancelled train.

Where station designs on the platform area are not symmetrical it will be necessary to cancel a train on the least popular platform to ensure designs have been sufficiently tested.

List of Input Assumptions

	CRL	LU
1. CAD (Extent of Model)	Y	Y
2. TPH	Y	Y
3. Escalator Config.		
4. Gateline Config.		
5. Ticketing		
6. PRM Routings and Rules		
7. Non-PRM Routings		
8. One-Way System Elements		
9. CRL Adit Usage	Y	Y
10. CRL Timetable	Y	Y
11. CRL Cancelled Train Logic		
12. LU Timetable		
13. NR / Other Timetable		
14. Constraining Alighters Logic	Y	Y
15. Constraining Boarders Logic		
16. Boarding Profiles (CRL)	Y	Y
17. Boarding Profiles (LU / Other)		
18. Alighting Profiles (CRL)	Y	Y
19. Alighting Profiles (LU / Other)		
20. Boarding Logic	Y	Y
21. Dwell Time Logic	Y	Y
22. 15 Minute Profiling	Y	Y
23. TPH broken up into 15 minute periods	Y	Y
24. 15 Minute Demand to Train Services	Y	Y
25. B & A Percentages	Y	Y
26. Accuracy of Seams		

INPUT 12: LU Timetable

Not relevant for the Bond Street Crossrail Model.

Learning Legacy Document

List of Input Assumptions

CRL LU

INPUT 13: NR / Other Timetable

1. CAD (Extent of Model)	Y	Y
2. TPH	Y	Y
3. Escalator Config.		
4. Gateline Config.		
5. Ticketing		
6. PRM Routings and Rules		
7. Non-PRM Routings		
8. One-Way System Elements		
9. CRL Adit Usage	Y	Y
10. CRL Timetable	Y	Y
11. CRL Cancelled Train Logic		
12. LU Timetable		
13. NR / Other Timetable		
14. Constraining Alighters Logic	Y	Y
15. Constraining Boarders Logic		
16. Boarding Profiles (CRL)	Y	Y
17. Boarding Profiles (LU / Other)		
18. Alighting Profiles (CRL)	Y	Y
19. Alighting Profiles (LU / Other)		
20. Boarding Logic	Y	Y
21. Dwell Time Logic	Y	Y
22. 15 Minute Profiling	Y	Y
23. TPH broken up into 15 minute periods	Y	Y
24. 15 Minute Demand to Train Services	Y	Y
25. B & A Percentages	Y	Y
26. Accuracy of Seams		

Not relevant for the Bond Street Crossrail Model.

Learning Legacy Document

List of Input Assumptions

CRL	LU
Y	Y
Y	Y
Y	Y
Y	Y
Y	Y
Y	Y
Y	Y
Y	Y
Y	Y
Y	Y
Y	Y
Y	Y
Y	Y

INPUT 14: Constraining Alighters Logic

**Mostly Applicable in AM Peak when there are generally more Alighters than Boarders**

Step 1:

Determine the Peak Fifteen Minutes

[Define : Peak fifteen minutes]

Step 2:

Determine the CRL service in the peak fifteen minutes with the highest number of alighters that will be placed on subsequent trains following a cancellation

[Define : Direction + (from Origin)]

Choose from:

- |                          |                            |
|--------------------------|----------------------------|
| CRL WB (from Abbey Wood) | CRL EB (from Paddington)   |
| CRL WB (from Shenfield)  | CRL EB (from Maidenhead)   |
|                          | CRL EB (from Heathrow)     |
|                          | CRL EB (from West Drayton) |

(N.B. Please ensure that the cancelled train is the first appropriate service in the Peak fifteen minutes in question, this will ensure that any effect of a cancellation is sufficiently captured in any congestion plots / outputs from the peak fifteen period in question)

Step 3:

Calculate the maximum number of alighters at any one time from a 'Direction + (from Origin)' service

[Define : Max Number of Alighters]

Step 4:

Calculate the number of alighters displaced from the cancelled train and add these appropriately to the alighters already due on subsequent train(s)

[Define : Revised Alighting Load On Subsequent Train(s)]

Step 5:

- a If Revised Alighting Load On ANY Subsequent Train ≤ Max Number of Alighters then subsequent train Alighting Load = OKAY
- b If Revised Alighting Load On ANY Subsequent Train > Max Number of Alighters then subsequent train Alighting Load = Max Number of Alighters

Step 6:

If Step 5b takes precedence over Step 5a then place [ Revised Alighting Load On Subsequent Train(s) - [Max Number of Alighters] ] excess passengers on further appropriate subsequent trains

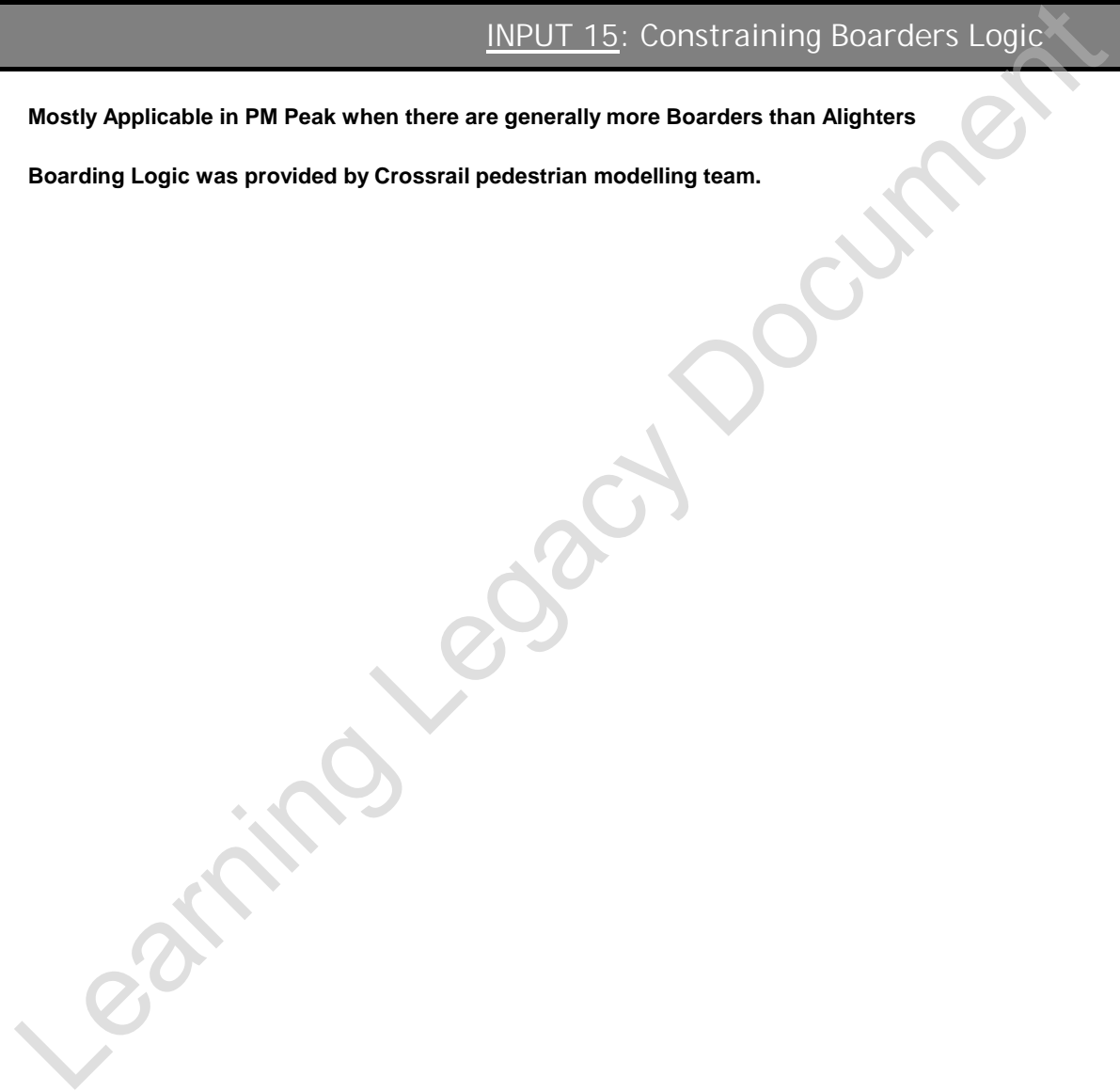
[Max Number of Alighters] =	Percentage of Trainload from a [Direction + (from Origin)] Service Alighting at Whitechapel x Capacity of a CRL Train
-----------------------------	---

INPUT 15: Constraining Boarders Logic

List of Input Assumptions	CRL	LU
1. CAD (Extent of Model)	Y	Y
2. TPH	Y	Y
3. Escalator Config.		
4. Gateline Config.		
5. Ticketing		
6. PRM Routings and Rules		
7. Non-PRM Routings		
8. One-Way System Elements		
9. CRL Adit Usage	Y	Y
10. CRL Timetable	Y	Y
11. CRL Cancelled Train Logic		
12. LU Timetable		
13. NR / Other Timetable		
14. Constraining Alighters Logic	Y	Y
15. Constraining Boarders Logic		
16. Boarding Profiles (CRL)	Y	Y
17. Boarding Profiles (LU / Other)		
18. Alighting Profiles (CRL)	Y	Y
19. Alighting Profiles (LU / Other)		
20. Boarding Logic	Y	Y
21. Dwell Time Logic	Y	Y
22. 15 Minute Profiling	Y	Y
23. TPH broken up into 15 minute periods	Y	Y
24. 15 Minute Demand to Train Services	Y	Y
25. B & A Percentages	Y	Y
26. Accuracy of Seams		

Mostly Applicable in PM Peak when there are generally more Boarders than Alighters

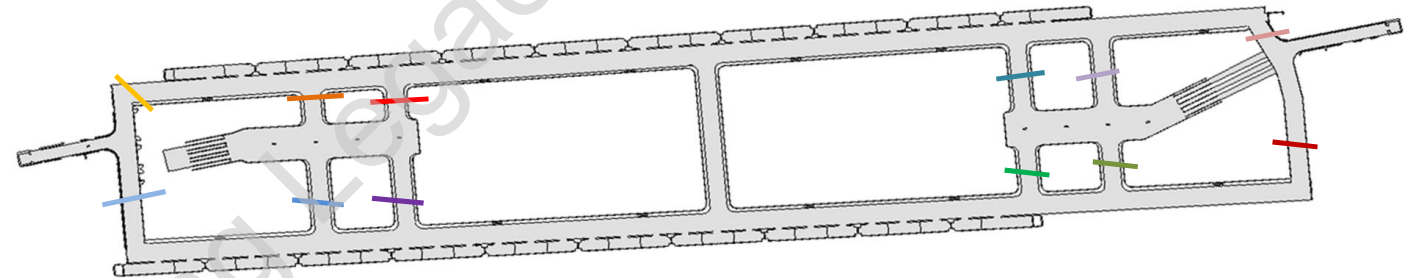
Boarding Logic was provided by Crossrail pedestrian modelling team.



List of Input Assumptions	CRL	LU
1. CAD (Extent of Model)	Y	Y
2. TPH	Y	Y
3. Escalator Config.		
4. Gateline Config.		
5. Ticketing		
6. PRM Routings and Rules		
7. Non-PRM Routings		
8. One-Way System Elements		
9. CRL Adit Usage	Y	Y
10. CRL Timetable	Y	Y
11. CRL Cancelled Train Logic		
12. LU Timetable		
13. NR / Other Timetable		
14. Constraining Alighters Logic	Y	Y
15. Constraining Boarders Logic		
16. Boarding Profiles (CRL)	Y	Y
17. Boarding Profiles (LU / Other)		
18. Alighting Profiles (CRL)	Y	Y
19. Alighting Profiles (LU / Other)		
20. Boarding Logic	Y	Y
21. Dwell Time Logic	Y	Y
22. 15 Minute Profiling	Y	Y
23. TPH broken up into 15 minute periods	Y	Y
24. 15 Minute Demand to Train Services	Y	Y
25. B & A Percentages	Y	Y
26. Accuracy of Seams	Y	Y

INPUT 16: Boarding Profiles (CRL)

CRL EB Platform Entrances										
Car 10	Car 9	Car 8	Car 7	Car 6	Car 5	Car 4	Car 3	Car 2	Car 1	
40.0%	30.0%	20.0%	10.0%	0.0%	0.0%	0.0%	0.0%	0.0%	0.0%	100.0%
14.5%	16.0%	15.0%	14.0%	12.5%	10.0%	8.0%	5.5%	3.5%	1.0%	100.0%
5.0%	12.0%	16.0%	16.0%	15.0%	12.5%	11.0%	7.5%	4.5%	0.5%	100.0%
1.5%	2.5%	4.5%	7.5%	10.5%	12.5%	15.0%	15.0%	16.0%	15.0%	100.0%
1.0%	1.0%	4.0%	7.0%	10.0%	12.0%	14.0%	16.0%	17.0%	18.0%	100.0%
0.0%	0.0%	0.0%	0.0%	0.0%	0.0%	5.0%	17.5%	32.5%	45.0%	100.0%



CRL WB Platform Entrances									
Car 1	Car 2	Car 3	Car 4	Car 5	Car 6	Car 7	Car 8	Car 9	Car 10
40.0%	30.0%	20.0%	10.0%	0.0%	0.0%	0.0%	0.0%	0.0%	100.0%
14.0%	15.0%	15.0%	14.0%	12.0%	10.0%	8.0%	6.0%	4.0%	2.0%
4.0%	11.0%	16.0%	16.0%	15.0%	13.0%	11.0%	8.0%	5.0%	1.0%
1.0%	1.0%	4.0%	7.0%	10.0%	12.0%	14.0%	16.0%	17.0%	18.0%
1.0%	1.0%	4.0%	7.0%	10.0%	12.0%	14.0%	16.0%	17.0%	18.0%
0.0%	0.0%	0.0%	0.0%	0.0%	0.0%	5.0%	17.5%	32.5%	45.0%

List of Input Assumptions	CRL	LU	INPUT 17: Boarding Profiles (LU / Other)
1. CAD (Extent of Model)	Y	Y	Not relevant for the Bond Street Crossrail Model.
2. TPH	Y	Y	
3. Escalator Config.			
4. Gateline Config.			
5. Ticketing			
6. PRM Routings and Rules			
7. Non-PRM Routings			
8. One-Way System Elements			
9. CRL Adit Usage	Y	Y	
10. CRL Timetable	Y	Y	
11. CRL Cancelled Train Logic			
12. LU Timetable			
13. NR / Other Timetable			
14. Constraining Alighters Logic	Y	Y	
15. Constraining Boarders Logic			
16. Boarding Profiles (CRL)	Y	Y	
17. Boarding Profiles (LU / Other)			
18. Alighting Profiles (CRL)	Y	Y	
19. Alighting Profiles (LU / Other)			
20. Boarding Logic	Y	Y	
21. Dwell Time Logic	Y	Y	
22. 15 Minute Profiling	Y	Y	
23. TPH broken up into 15 minute periods	Y	Y	
24. 15 Minute Demand to Train Services	Y	Y	
25. B & A Percentages	Y	Y	
26. Accuracy of Seams			

Learning Legacy Document



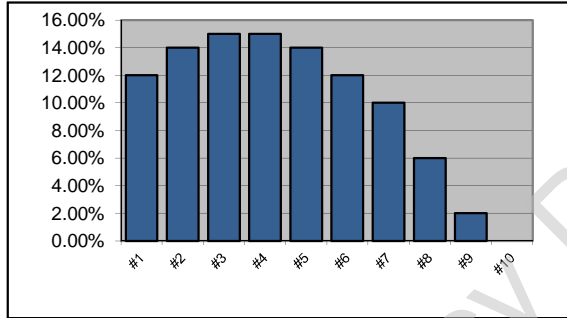
List of Input Assumptions

CRL LU

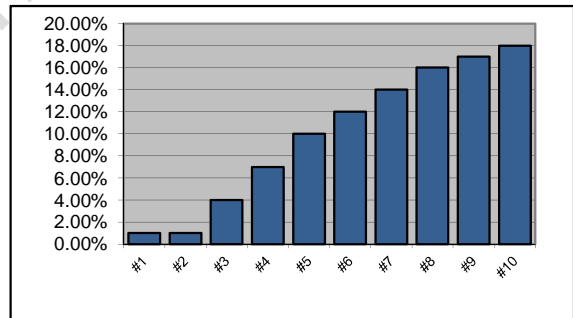
INPUT 18: Alighting Profiles (CRL)

- 1. CAD (Extent of Model) Y Y
- 2. TPH Y Y
- 3. Escalator Config. Y Y
- 4. Gateline Config. Y Y
- 5. Ticketing Y Y
- 6. PRM Routings and Rules Y Y
- 7. Non-PRM Routings Y Y
- 8. One-Way System Elements Y Y
- 9. CRL Adit Usage Y Y
- 10. CRL Timetable Y Y
- 11. CRL Cancelled Train Logic Y Y
- 12. LU Timetable Y Y
- 13. NR / Other Timetable Y Y
- 14. Constraining Alighters Logic Y Y
- 15. Constraining Boarders Logic Y Y
- 16. Boarding Profiles (CRL) Y Y
- 17. Boarding Profiles (LU / Other) Y Y
- 18. Alighting Profiles (CRL) Y Y
- 19. Alighting Profiles (LU / Other) Y Y
- 20. Boarding Logic Y Y
- 21. Dwell Time Logic Y Y
- 22. 15 Minute Profiling Y Y
- 23. TPH broken up into 15 minute periods Y Y
- 24. 15 Minute Demand to Train Services Y Y
- 25. B & A Percentages Y Y
- 26. Accuracy of Seams Y Y

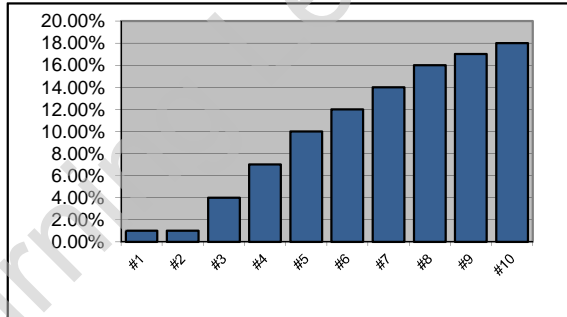
Platform Name	
CRL WB (Davies St)	
Car	%
#1	12.00%
#2	14.00%
#3	15.00%
#4	15.00%
#5	14.00%
#6	12.00%
#7	10.00%
#8	6.00%
#9	2.00%
#10	0.00%
<u>100.00%</u>	



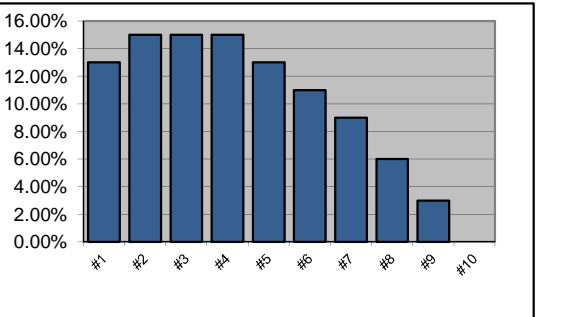
Platform Name	
CRL WB (Hanover Sq)	
Car	%
#1	1.00%
#2	1.00%
#3	4.00%
#4	7.00%
#5	10.00%
#6	12.00%
#7	14.00%
#8	16.00%
#9	17.00%
#10	18.00%
<u>100.00%</u>	



Platform Name	
CRL EB (Davies St)	
Car	%
#1	1.00%
#2	1.00%
#3	4.00%
#4	7.00%
#5	10.00%
#6	12.00%
#7	14.00%
#8	16.00%
#9	17.00%
#10	18.00%
<u>100.00%</u>	



Platform Name	
CRL EB (Hanover Sq)	
Car	%
#1	13.00%
#2	15.00%
#3	15.00%
#4	15.00%
#5	13.00%
#6	11.00%
#7	9.00%
#8	6.00%
#9	3.00%
#10	0.00%
<u>100.00%</u>	



List of Input Assumptions

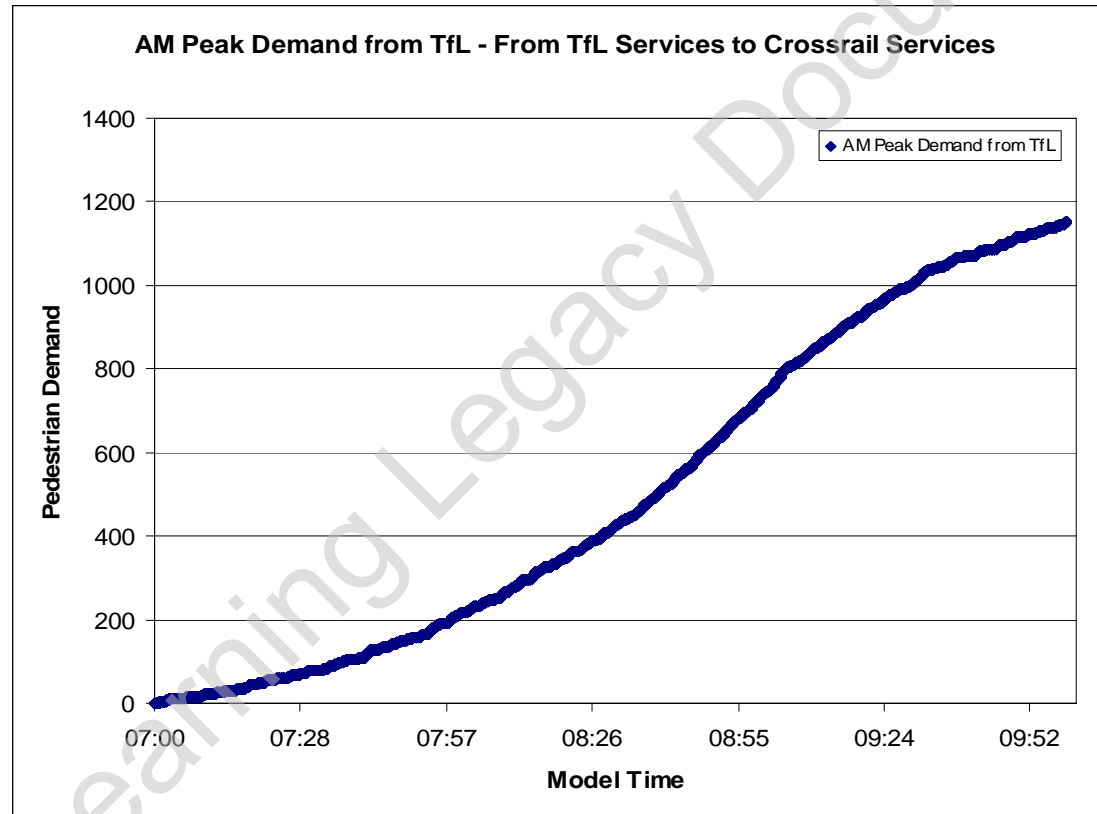
	C	A	I
1. CAD (Extent of Model)	Y	Y	
2. TPH	Y	Y	
3. Escalator Config.	Y		
4. Gateline Config.	Y		
5. Ticketing			
6. PRM Routings and Rules	Y		
7. Non-PRM Routings	Y		
8. One-Way System Elements	Y		
9. CRL Adit Usage	Y	Y	
10. CRL Timetable	Y	Y	
11. CRL Cancelled Train Logic			
12. LU Timetable			
13. NR / Other Timetable			
14. Constraining Alighters Logic	Y	Y	
15. Constraining Boarders Logic			
16. Boarding Profiles (CRL)	Y	Y	
17. Boarding Profiles (LU / Other)			
18. Alighting Profiles (CRL)	Y	Y	
19. Alighting Profiles (LU / Other)			
20. Boarding Logic	Y	Y	
21. Dwell Time Logic	Y	Y	
22. 15 Minute Profiling	Y	Y	
23. TPH broken up into 15 minute periods	Y	Y	
24. 15 Minute Demand to Train Services	Y	Y	
25. B & A Percentages	Y	Y	
26. Accuracy of Seams	Y		

INPUT 19: Alighting Profiles (LU / Other)

This is the profile of demand provided by LU for the arrival of pedestrians into Bond Street Crossrail from LUL services - This has been taken from the Bond Street Upgrade Legion Model. This profile has been used and applied to the predicted demand from the LUL tunnel.

LGM File: I:\BND Bond Street\J090xx Bond Street Modelling Assurance for RUP\BOS XRL 2017 AMBOS XRL AM 2017\_RevB.lgm

RES File: I:\BND Bond Street\J090xx Bond Street Modelling Assurance for RUP\BOS XRL 2017 AMBOS XRL AM 2017\_RevB\_Base.res



List of Input Assumptions

CRL LU

INPUT 20: Boarding Logic

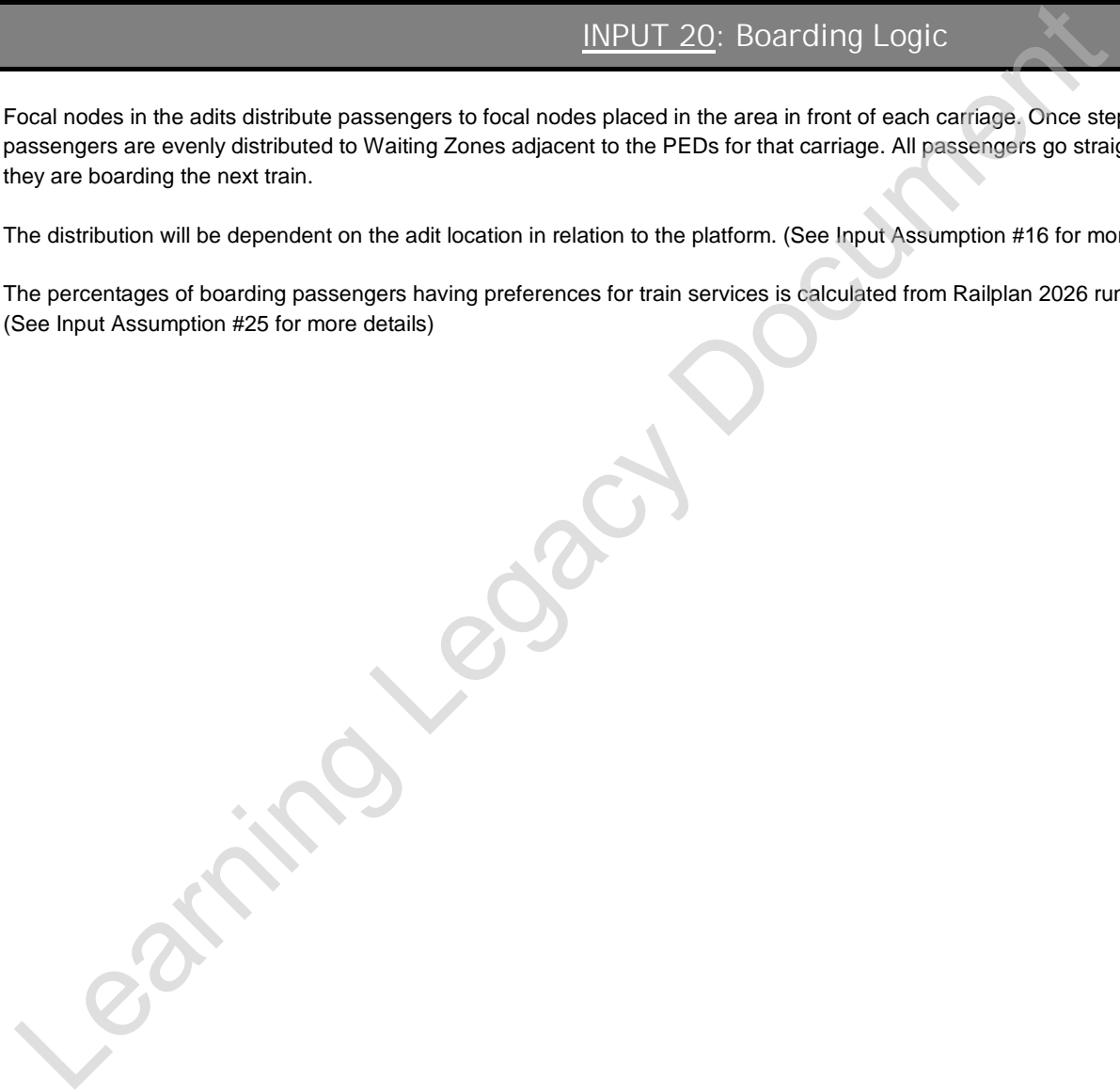
1. CAD (Extent of Model)	Y	Y
2. TPH	Y	Y
3. Escalator Config.		
4. Gateline Config.		
5. Ticketing		
6. PRM Routings and Rules		
7. Non-PRM Routings		
8. One-Way System Elements		
9. CRL Adit Usage	Y	Y
10. CRL Timetable	Y	Y
11. CRL Cancelled Train Logic		
12. LU Timetable		
13. NR / Other Timetable		
14. Constraining Alighters Logic	Y	Y
15. Constraining Boarders Logic		
16. Boarding Profiles (CRL)	Y	Y
17. Boarding Profiles (LU / Other)		
18. Alighting Profiles (CRL)	Y	Y
19. Alighting Profiles (LU / Other)		
20. Boarding Logic	Y	Y
21. Dwell Time Logic	Y	Y
22. 15 Minute Profiling	Y	Y
23. TPH broken up into 15 minute periods	Y	Y
24. 15 Minute Demand to Train Services	Y	Y
25. B & A Percentages	Y	Y
26. Accuracy of Seams		

Focal nodes in the adits distribute passengers to focal nodes placed in the area in front of each carriage. Once stepped inside these carriage focal nodes passengers are evenly distributed to Waiting Zones adjacent to the PEDs for that carriage. All passengers go straight to the PEDs regardless of whether or not they are boarding the next train.

The distribution will be dependent on the adit location in relation to the platform. (See Input Assumption #16 for more details)

The percentages of boarding passengers having preferences for train services is calculated from Railplan 2026 run:  
(See Input Assumption #25 for more details)

XR153Ru



List of Input Assumptions

CRL LU

INPUT 21: Dwell Time Logic

1. CAD (Extent of Model)	Y	Y
2. TPH	Y	Y
3. Escalator Config.		
4. Gateline Config.		
5. Ticketing		
6. PRM Routings and Rules		
7. Non-PRM Routings		
8. One-Way System Elements		
9. CRL Adit Usage	Y	Y
10. CRL Timetable	Y	Y
11. CRL Cancelled Train Logic		
12. LU Timetable		
13. NR / Other Timetable		
14. Constraining Alighters Logic	Y	Y
15. Constraining Boarders Logic		
16. Boarding Profiles (CRL)	Y	Y
17. Boarding Profiles (LU / Other)		
18. Alighting Profiles (CRL)	Y	Y
19. Alighting Profiles (LU / Other)		
20. Boarding Logic	Y	Y
21. Dwell Time Logic	Y	Y
22. 15 Minute Profiling	Y	Y
23. TPH broken up into 15 minute periods	Y	Y
24. 15 Minute Demand to Train Services	Y	Y
25. B & A Percentages	Y	Y
26. Accuracy of Seams		

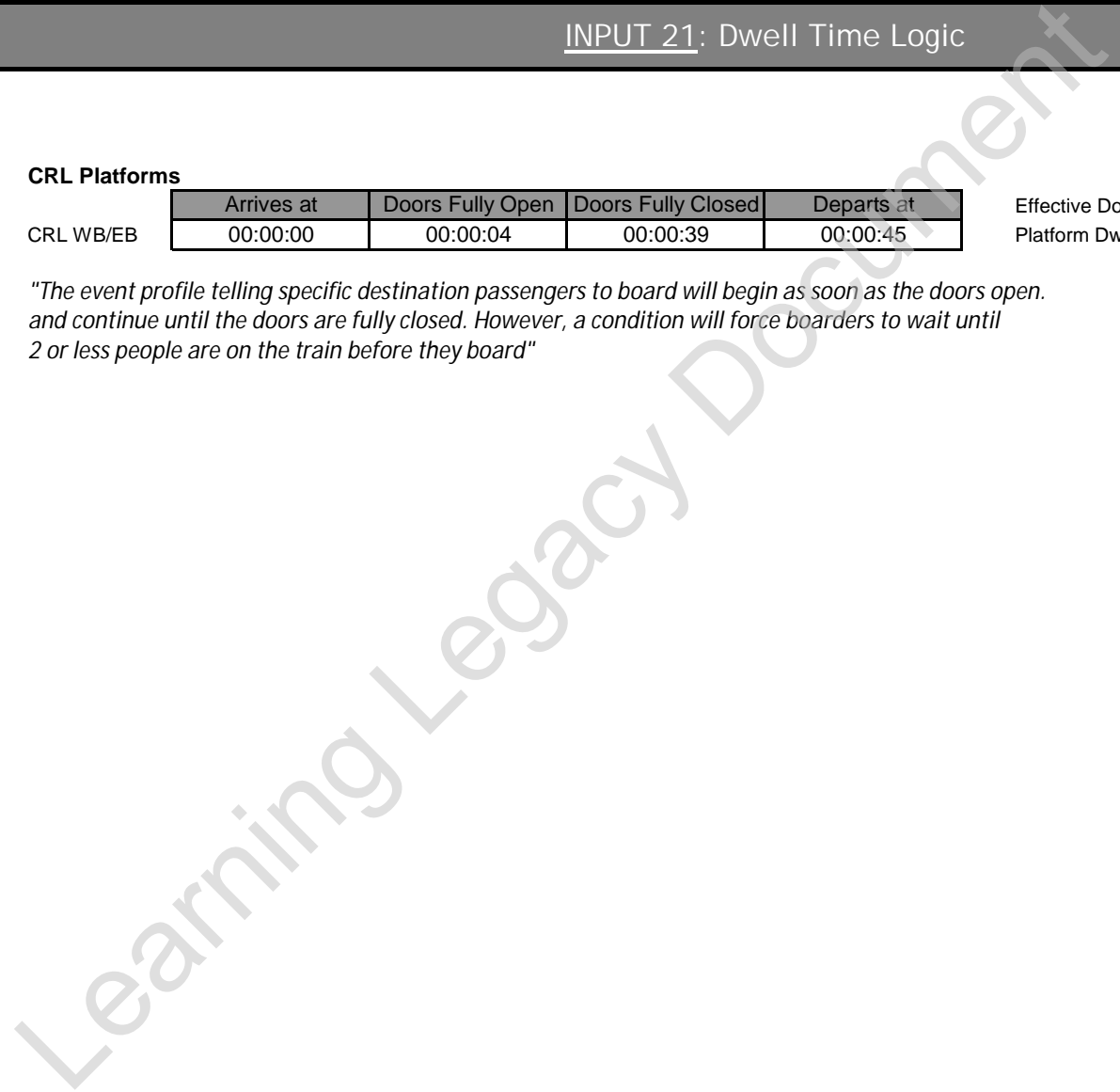
CRL Platforms

	Arrives at	Doors Fully Open	Doors Fully Closed	Departs at
CRL WB/EB	00:00:00	00:00:04	00:00:39	00:00:45

Effective Door Opening Time  
Platform Dwell Time

00:00:35
00:00:45

"The event profile telling specific destination passengers to board will begin as soon as the doors open. and continue until the doors are fully closed. However, a condition will force boarders to wait until 2 or less people are on the train before they board"



List of Input Assumptions

CRL LU

INPUT 22: Fifteen Minute Profiling

1. CAD (Extent of Model)

Y Y

2. TPH

Y Y

3. Escalator Config.

Y Y

4. Gateline Config.

Y Y

5. Ticketing

Y Y

6. PRM Routings and Rules

Y Y

7. Non-PRM Routings

Y Y

8. One-Way System Elements

Y Y

9. CRL Adit Usage

Y Y

10. CRL Timetable

Y Y

11. CRL Cancelled Train Logic

Y Y

12. LU Timetable

Y Y

13. NR / Other Timetable

Y Y

14. Constraining Alighters Logic

Y Y

15. Constraining Boarders Logic

Y Y

16. Boarding Profiles (CRL)

Y Y

17. Boarding Profiles (LU / Other)

Y Y

18. Alighting Profiles (CRL)

Y Y

19. Alighting Profiles (LU / Other)

Y Y

20. Boarding Logic

Y Y

21. Dwell Time Logic

Y Y

22. 15 Minute Profiling

Y Y

23. TPH broken up into 15 minute periods

Y Y

24. 15 Minute Demand to Train Services

Y Y

25. B & A Percentages

Y Y

26. Accuracy of Seams

Y Y

Entrance A: CRL WB Train

07:00-07:15	07:15-07:30	07:30-07:45	07:45-08:00	08:00-08:15	08:15-08:30	08:30-08:45	08:45-09:00	09:00-09:15	09:15-09:30	09:30-09:45	09:45-10:00	
3.02%	4.21%	5.66%	7.01%	8.18%	9.80%	11.64%	12.68%	11.92%	10.18%	8.46%	7.25%	100.00% (Proxy)

Entrance B: CRL EB Train

07:00-07:15	07:15-07:30	07:30-07:45	07:45-08:00	08:00-08:15	08:15-08:30	08:30-08:45	08:45-09:00	09:00-09:15	09:15-09:30	09:30-09:45	09:45-10:00	
3.65%	4.88%	6.25%	7.63%	9.12%	10.82%	12.12%	12.10%	10.73%	8.96%	7.45%	6.29%	100.00% (Proxy)

Entrance C: Davies Street Entrance

07:00-07:15	07:15-07:30	07:30-07:45	07:45-08:00	08:00-08:15	08:15-08:30	08:30-08:45	08:45-09:00	09:00-09:15	09:15-09:30	09:30-09:45	09:45-10:00	
3.37%	4.27%	5.36%	6.50%	7.94%	9.33%	10.27%	10.42%	10.42%	10.47%	10.76%	10.91%	100.00%

Entrance D: Hanover Square Entrance

07:00-07:15	07:15-07:30	07:30-07:45	07:45-08:00	08:00-08:15	08:15-08:30	08:30-08:45	08:45-09:00	09:00-09:15	09:15-09:30	09:30-09:45	09:45-10:00	
3.37%	4.27%	5.36%	6.50%	7.94%	9.33%	10.27%	10.42%	10.42%	10.47%	10.76%	10.91%	100.00%

RODS 2008 has been used to profile  
Proxy CRL WB with CEN WB  
Proxy CRL EB with CEN EB

List of Input Assumptions

CRL LU

INPUT 23: TPH broken up 15 into minute periods

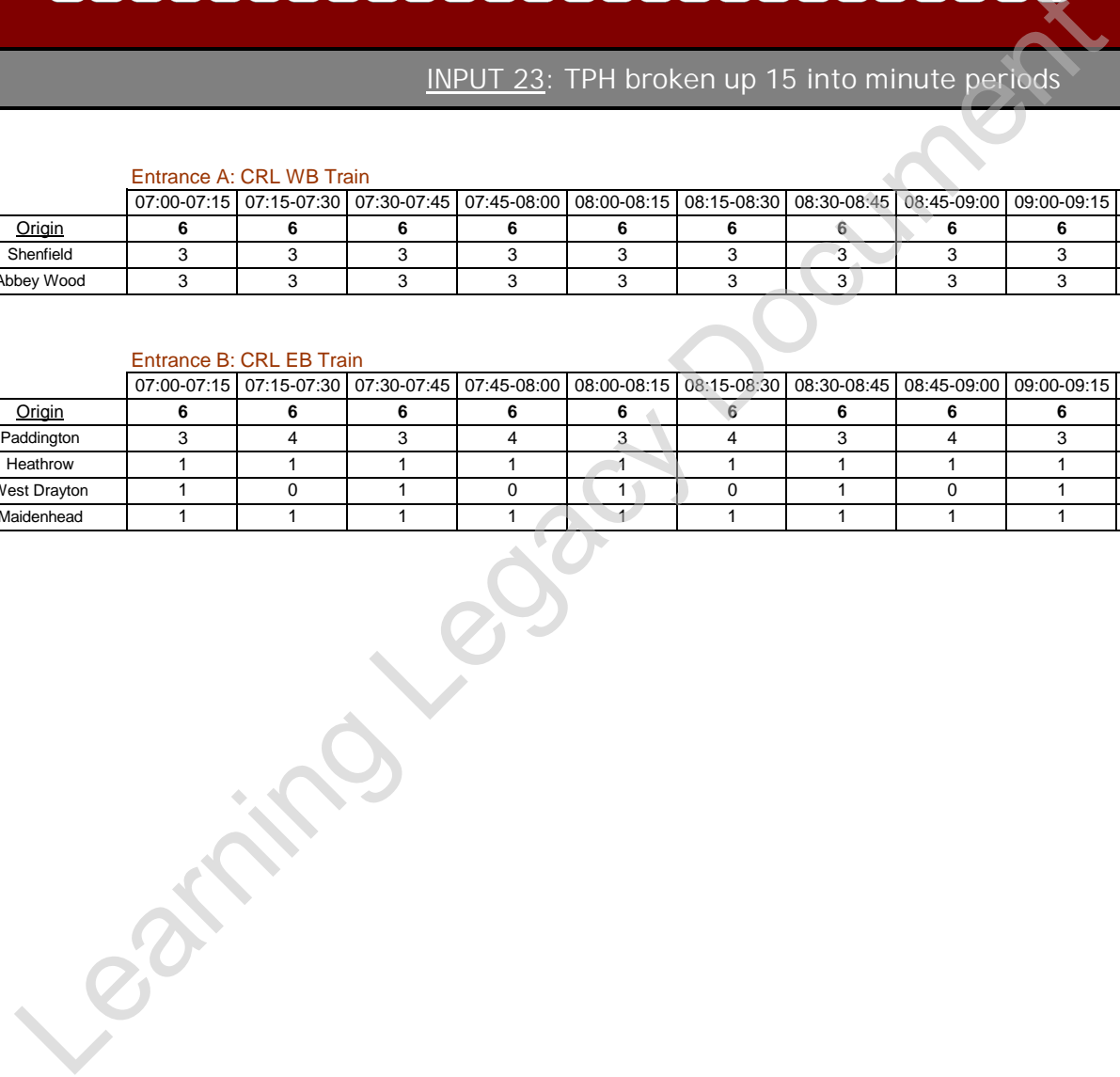
- 1. CAD (Extent of Model) Y Y
- 2. TPH Y Y
- 3. Escalator Config. Y Y
- 4. Gateline Config. Y Y
- 5. Ticketing Y Y
- 6. PRM Routings and Rules Y Y
- 7. Non-PRM Routings Y Y
- 8. One-Way System Elements Y Y
- 9. CRL Adit Usage Y Y
- 10. CRL Timetable Y Y
- 11. CRL Cancelled Train Logic Y Y
- 12. LU Timetable Y Y
- 13. NR / Other Timetable Y Y
- 14. Constraining Alighters Logic Y Y
- 15. Constraining Boarders Logic Y Y
- 16. Boarding Profiles (CRL) Y Y
- 17. Boarding Profiles (LU / Other) Y Y
- 18. Alighting Profiles (CRL) Y Y
- 19. Alighting Profiles (LU / Other) Y Y
- 20. Boarding Logic Y Y
- 21. Dwell Time Logic Y Y
- 22. 15 Minute Profiling Y Y
- 23. TPH broken up into 15 minute periods Y Y
- 24. 15 Minute Demand to Train Services Y Y
- 25. B & A Percentages Y Y
- 26. Accuracy of Seams Y Y

Entrance A: CRL WB Train

	07:00-07:15	07:15-07:30	07:30-07:45	07:45-08:00	08:00-08:15	08:15-08:30	08:30-08:45	08:45-09:00	09:00-09:15	09:15-09:30	09:30-09:45	09:45-10:00
<u>Origin</u>	6	6	6	6	6	6	6	6	6	6	6	6
Shenfield	3	3	3	3	3	3	3	3	3	3	3	3
Abbey Wood	3	3	3	3	3	3	3	3	3	3	3	3

Entrance B: CRL EB Train

	07:00-07:15	07:15-07:30	07:30-07:45	07:45-08:00	08:00-08:15	08:15-08:30	08:30-08:45	08:45-09:00	09:00-09:15	09:15-09:30	09:30-09:45	09:45-10:00
<u>Origin</u>	6	6	6	6	6	6	6	6	6	6	6	6
Paddington	3	4	3	4	3	4	3	4	3	4	3	4
Heathrow	1	1	1	1	1	1	1	1	1	1	1	1
West Drayton	1	0	1	0	1	0	1	0	1	0	1	0
Maidenhead	1	1	1	1	1	1	1	1	1	1	1	1



INPUT 24: 15 Minute Demand to Train Services

List of Input Assumptions

CRL LU

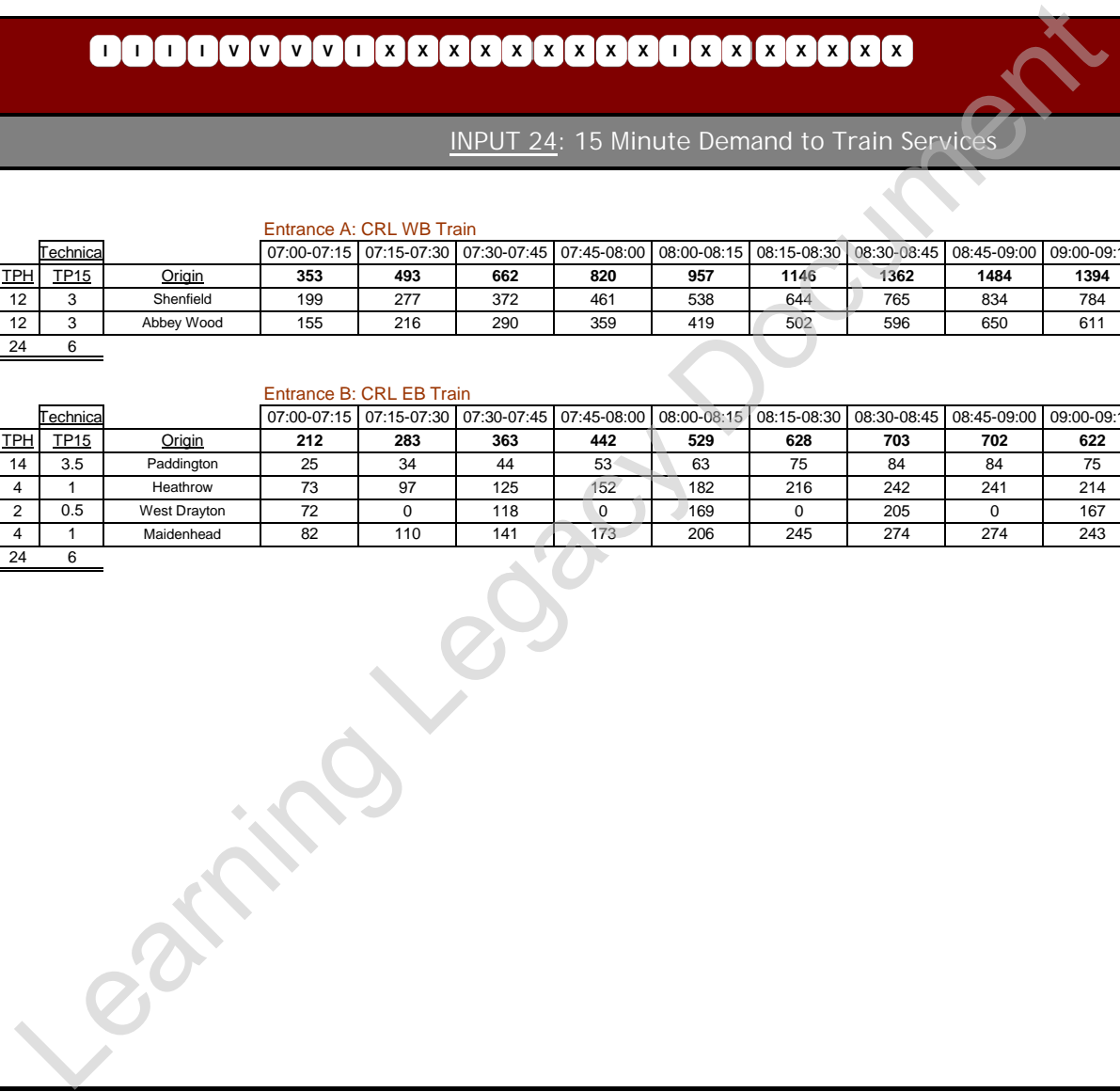
- 1. CAD (Extent of Model) Y Y
- 2. TPH Y Y
- 3. Escalator Config. Y Y
- 4. Gateine Config. Y Y
- 5. Ticketing Y Y
- 6. PRM Routings and Rules Y Y
- 7. Non-PRM Routings Y Y
- 8. One-Way System Elements Y Y
- 9. CRL Adit Usage Y Y
- 10. CRL Timetable Y Y
- 11. CRL Cancelled Train Logic Y Y
- 12. LU Timetable Y Y
- 13. NR / Other Timetable Y Y
- 14. Constraining Alighters Logic Y Y
- 15. Constraining Boarders Logic Y Y
- 16. Boarding Profiles (CRL) Y Y
- 17. Boarding Profiles (LU / Other) Y Y
- 18. Alighting Profiles (CRL) Y Y
- 19. Alighting Profiles (LU / Other) Y Y
- 20. Boarding Logic Y Y
- 21. Dwell Time Logic Y Y
- 22. 15 Minute Profiling Y Y
- 23. TPH broken up into 15 minute periods Y Y
- 24. 15 Minute Demand to Train Services Y Y
- 25. B & A Percentages Y Y
- 26. Accuracy of Seams Y Y

Entrance A: CRL WB Train

			Technica													
Popularity	TPH	TP15	Origin	07:00-07:15	07:15-07:30	07:30-07:45	07:45-08:00	08:00-08:15	08:15-08:30	08:30-08:45	08:45-09:00	09:00-09:15	09:15-09:30	09:30-09:45	09:45-10:00	
56%	12	3	Shenfield	353	493	662	820	957	1146	1362	1484	1394	1191	989	848	11700
44%	12	3	Abbey Wood	199	277	372	461	538	644	765	834	784	669	556	477	
100%	24	6														

Entrance B: CRL EB Train

			Technica													
Popularity	TPH	TP15	Origin	07:00-07:15	07:15-07:30	07:30-07:45	07:45-08:00	08:00-08:15	08:15-08:30	08:30-08:45	08:45-09:00	09:00-09:15	09:15-09:30	09:30-09:45	09:45-10:00	
12%	14	3.5	Paddington	25	34	44	53	63	75	84	84	75	62	52	44	5800
34%	4	1	Heathrow	73	97	125	152	182	216	242	241	214	179	149	126	
15%	2	0.5	West Drayton	72	0	118	0	169	0	205	0	167	0	116	0	
39%	4	1	Maidenhead	82	110	141	173	206	245	274	274	243	203	169	142	
100%	24	6														



INPUT 25: B & A Percentages

List of Input Assumptions	CRL	LU
1. CAD (Extent of Model)	Y	Y
2. TPH	Y	Y
3. Escalator Config.		
4. Gateline Config.		
5. Ticketing		
6. PRM Routings and Rules		
7. Non-PRM Routings		
8. One-Way System Elements		
9. CRL Adit Usage	Y	Y
10. CRL Timetable	Y	Y
11. CRL Cancelled Train Logic		
12. LU Timetable		
13. NR / Other Timetable		
14. Constraining Alighters Logic	Y	Y
15. Constraining Boarders Logic		
16. Boarding Profiles (CRL)	Y	Y
17. Boarding Profiles (LU / Other)		
18. Alighting Profiles (CRL)	Y	Y
19. Alighting Profiles (LU / Other)		
20. Boarding Logic	Y	Y
21. Dwell Time Logic	Y	Y
22. 15 Minute Profiling	Y	Y
23. TPH broken up into 15 minute periods	Y	Y
24. 15 Minute Demand to Train Services	Y	Y
25. B & A Percentages	Y	Y
26. Accuracy of Seams		

Railplan Source:  (2026XR)

**CRL**  
Boarding Percentages

CRL WB Any (Destination is Paddington)	8.5%
CRL WB Any Post PAD-WD (Destination is stations between Paddington and West Drayton)	49.5%
CRL WB Heathrow (Destination is Heathrow Airport)	11.7%
CRL WB Any Post WD-MAID (Destination is stations between West Drayton and Maidenhead)	30.3%
<b>100%</b>	

CRL EB Any (Destination is any station between TCR and Whitechapel)	15.1%
CRL EB Shenfield (Destination is any station on the Shenfield Branch)	18.5%
CRL EB Abbey Wood (Destination is any station on the Abbey Wood Branch)	66.4%
<b>100%</b>	

Alighting Percentages

Split of CRL WB Alighters originating from a Shenfield Service	56.2%
Split of CRL WB Alighters originating from a Abbey Wood Service	43.8%
<b>100%</b>	
Split of CRL EB Alighters originating from a Paddington Service	12.0%
Split of CRL EB Alighters originating from a Heathrow Service	34.4%
Split of CRL EB Alighters originating from a West Drayton Service	14.6%
Split of CRL EB Alighters originating from a Maidenhead Service	39.0%
<b>100%</b>	

Train Load Percentages (for assistance with logic around impact on Cancelled Train)

Percentage of a WB train load from Shenfield alighting at Whitechapel	
Percentage of a WB train load from Abbey Wood alighting at Whitechapel	
Percentage of a WB train load from Paddington alighting at Whitechapel	
Percentage of a WB train load from Heathrow alighting at Whitechapel	
Percentage of a WB train load from West Drayton alighting at Whitechapel	
Percentage of a WB train load from Maidenhead alighting at Whitechapel	



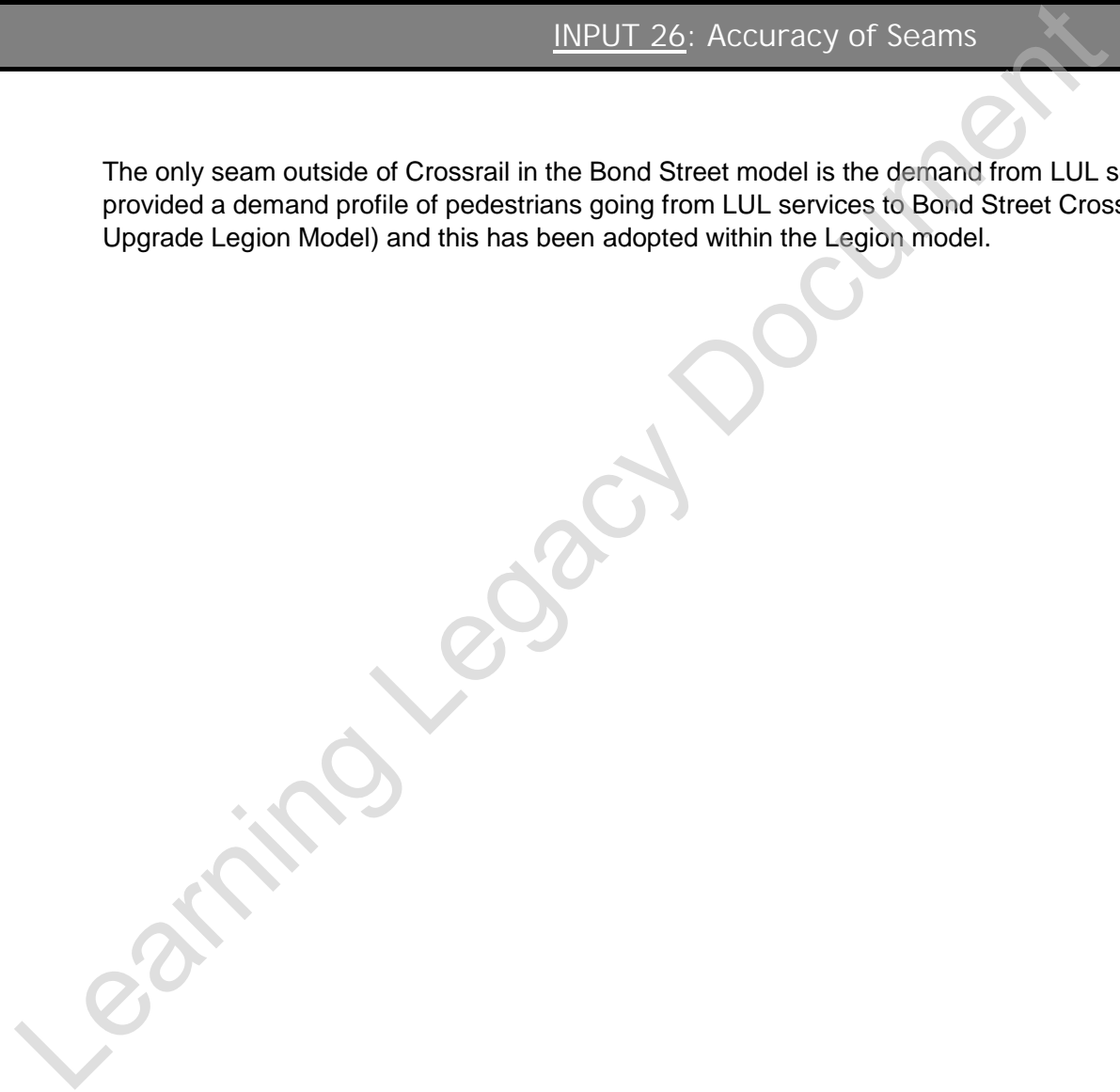
List of Input Assumptions

CRL LU

INPUT 26: Accuracy of Seams

The only seam outside of Crossrail in the Bond Street model is the demand from LUL services. LU have provided a demand profile of pedestrians going from LUL services to Bond Street Crossrail (from the Bond Street Upgrade Legion Model) and this has been adopted within the Legion model.

1. CAD (Extent of Model)	Y	Y
2. TPH	Y	Y
3. Escalator Config.		
4. Gateline Config.		
5. Ticketing		
6. PRM Routings and Rules		
7. Non-PRM Routings		
8. One-Way System Elements		
9. CRL Adit Usage	Y	Y
10. CRL Timetable	Y	Y
11. CRL Cancelled Train Logic		
12. LU Timetable		
13. NR / Other Timetable		
14. Constraining Alighters Logic	Y	Y
15. Constraining Boarders Logic		
16. Boarding Profiles (CRL)	Y	Y
17. Boarding Profiles (LU / Other)		
18. Alighting Profiles (CRL)	Y	Y
19. Alighting Profiles (LU / Other)		
20. Boarding Logic	Y	Y
21. Dwell Time Logic	Y	Y
22. 15 Minute Profiling	Y	Y
23. TPH broken up into 15 minute periods	Y	Y
24. 15 Minute Demand to Train Services	Y	Y
25. B & A Percentages	Y	Y
26. Accuracy of Seams		



List of Input Assumptions

CRL LU

INPUT 27: PRM Types and Proportions

1. CAD (Extent of Model)

Y Y

2. TPH

Y Y

3. Escalator Config.

4. Gateline Config.

5. Ticketing

6. PRM Routings and Rules

7. Non-PRM Routings

8. One-Way System Elements

9. CRL Adit Usage

Y Y

10. CRL Timetable

Y Y

11. CRL Cancelled Train Logic

12. LU Timetable

13. NR / Other Timetable

14. Constraining Alighters Logic

Y Y

15. Constraining Boarders Logic

16. Boarding Profiles (CRL)

Y Y

17. Boarding Profiles (LU / Other)

18. Alighting Profiles (CRL)

Y Y

19. Alighting Profiles (LU / Other)

20. Boarding Logic

Y Y

21. Dwell Time Logic

Y Y

22. 15 Minute Profiling

Y Y

23. TPH broken up into 15 minute periods

Y Y

24. 15 Minute Demand to Train Services

Y Y

25. B & A Percentages

Y Y

26. Accuracy of Seams

27. PRM Types and Proportions

This is taken from the Multi-Disciplinary Consultant Works Package 2 Bond St Crossrail Station - Legion Modelling Report  
Bond St - SD3 Legion Modelling Report (ARUP)  
Document Number: CR-SD-BOS-CE-RT-00011

Table 9: 2016 PRM Types and proportions

Physically impaired			Encumbered			
Wheelchair User	Disabled	Elderly Impaired	Adults with Young Children	Heavy Shopping Bags	Medium Luggage	Large Luggage Items
A	B	B	E	C	C	D
0.010%	0.529%	0.389%	0.348%	1.020%	1.000%	0.405%
0.928%			2.773%			
3.701%						

BOND STREET			
Crossrail WB Platform - AM Peak - 2026 - 24 TPH			
	Origin	Destination	
CRL	07:01:09	07:01:54	ABW HRW
CRL	07:03:30	07:04:15	SHN PAD
CRL	07:06:17	07:07:02	ABW PAD
CRL	07:08:30	07:09:15	SHN PAD
CRL	07:10:59	07:11:44	ABW MHD
CRL	07:13:28	07:14:13	SHN PAD
CRL	07:16:13	07:16:58	ABW HRW
CRL	07:19:06	07:19:51	SHN PAD
CRL	07:21:36	07:22:21	ABW PAD
CRL	07:23:32	07:24:17	SHN MHD
CRL	07:25:56	07:26:41	ABW WDR
CRL	07:28:43	07:29:28	SHN PAD
CRL	07:31:14	07:31:59	ABW HRW
CRL	07:33:52	07:34:37	SHN PAD
CRL	07:36:24	07:37:09	ABW PAD
CRL	07:38:53	07:39:38	SHN PAD
CRL	07:41:14	07:41:59	ABW MHD
CRL	07:44:11	07:44:56	SHN PAD
CRL	07:46:41	07:47:26	ABW HRW
CRL	07:49:13	07:49:58	SHN PAD
CRL	07:51:25	07:52:10	ABW PAD
CRL	07:53:51	07:54:36	SHN MHD
CRL	07:56:47	07:57:32	ABW WDR
CRL	07:58:32	07:59:17	SHN PAD
CRL	08:00:59	08:01:44	ABW HRW
CRL	08:03:27	08:04:12	SHN PAD
CRL	08:05:56	08:06:41	ABW PAD
CRL	08:08:27	08:09:12	SHN PAD
CRL	08:11:28	08:12:13	ABW MHD
CRL	08:13:27	08:14:12	SHN PAD
CRL	08:16:07	08:16:52	ABW HRW
CRL	08:18:27	08:19:12	SHN PAD
CRL	08:20:59	08:21:44	ABW PAD
CRL	08:24:01	08:24:46	SHN MHD
CRL	08:26:09	08:26:54	ABW WDR
CRL	08:29:08	08:29:53	SHN PAD
CRL	08:30:59	08:31:44	ABW HRW
CRL	08:33:24	08:34:09	SHN PAD
CRL	08:36:11	08:36:56	ABW PAD
CRL	08:39:03	08:39:48	SHN PAD
CRL	08:41:27	08:42:12	ABW MHD
CRL	08:43:57	08:44:42	SHN PAD
CRL	08:45:57	08:46:42	ABW HRW
CRL	08:48:36	08:49:21	SHN PAD
CRL	08:51:48	08:52:33	ABW PAD
CRL	08:53:38	08:54:23	SHN MHD
CRL	08:56:06	08:56:51	ABW WDR
CRL	08:58:41	08:59:26	SHN PAD
CRL	09:01:17	09:02:02	ABW HRW
CRL	09:03:59	09:04:44	SHN PAD
CRL	09:06:04	09:06:49	ABW PAD
CRL	09:08:32	09:09:17	SHN PAD
CRL	09:11:13	09:11:58	ABW MHD
CRL	09:13:36	09:14:21	SHN PAD
CRL	09:16:33	09:17:18	ABW HRW
CRL	09:19:18	09:20:03	SHN PAD
CRL	09:21:00	09:21:45	ABW MHD
CRL	09:23:32	09:24:17	SHN PAD
CRL	09:26:40	09:27:25	ABW WDR
CRL	09:28:51	09:29:36	SHN PAD
CRL	09:31:30	09:32:15	ABW HRW
CRL	09:33:39	09:34:24	SHN PAD
CRL	09:36:10	09:36:55	ABW PAD
CRL	09:38:26	09:39:11	SHN PAD
CRL	09:41:02	09:41:47	ABW MHD
CRL	09:43:55	09:44:40	SHN PAD
CRL	09:46:37	09:47:22	ABW HRW
CRL	09:48:25	09:49:10	SHN PAD
CRL	09:51:09	09:51:54	ABW PAD
CRL	09:53:24	09:54:09	SHN MHD
CRL	09:55:55	09:56:40	ABW WDR
CRL	09:58:34	09:59:19	SHN PAD

Descriptive Stats	
Peak Period	AM Peak
Future Year	2026
Trains Per Hour	24

07:00 to 10:00			
CRL	72	100.00%	10 81
		0.00%	
<b>Total</b>	<b>72</b>		

07:00 to 08:00			
CRL	24	100.00%	10 33
		0.00%	
<b>Total</b>	<b>24</b>		

08:00 to 09:00			
CRL	24	100.00%	34 57
		0.00%	
<b>Total</b>	<b>24</b>		

09:00 to 10:00			
CRL	24	100.00%	58 81
		0.00%	
<b>Total</b>	<b>24</b>		

BOND STREET			
Crossrail WB Platform - PM Peak - 2026 - 24 TPH			
	Origin	Destination	
CRL	16:01:09	16:01:54	ABW PAD
CRL	16:03:30	16:04:15	SHN MHD
CRL	16:06:17	16:07:02	ABW WD
CRL	16:08:30	16:09:15	SHN PAD
CRL	16:10:59	16:11:44	ABW HRW
CRL	16:13:28	16:14:13	SHN PAD
CRL	16:16:13	16:16:58	ABW PAD
CRL	16:19:06	16:19:51	SHN PAD
CRL	16:21:36	16:22:21	ABW MHD
CRL	16:23:32	16:24:17	SHN PAD
CRL	16:25:56	16:26:41	ABW HRW
CRL	16:28:43	16:29:28	SHN PAD
CRL	16:31:14	16:31:59	ABW PAD
CRL	16:33:52	16:34:37	SHN MHD
CRL	16:36:24	16:37:09	ABW WD
CRL	16:38:53	16:39:38	SHN PAD
CRL	16:41:14	16:41:59	ABW HRW
CRL	16:44:11	16:44:56	SHN PAD
CRL	16:46:41	16:47:26	ABW PAD
CRL	16:49:13	16:49:58	SHN PAD
CRL	16:51:25	16:52:10	ABW MHD
CRL	16:53:51	16:54:36	SHN PAD
CRL	16:56:47	16:57:32	ABW HRW
CRL	16:58:32	16:59:17	SHN PAD
CRL	17:00:59	17:01:44	ABW PAD
CRL	17:03:27	17:04:12	SHN MHD
CRL	17:05:56	17:06:41	ABW WD
CRL	17:08:27	17:09:12	SHN PAD
CRL	17:11:28	17:12:13	ABW HRW
CRL	17:13:27	17:14:12	SHN PAD
CRL	17:16:07	17:16:52	ABW PAD
CRL	17:18:27	17:19:12	SHN PAD
CRL	17:20:59	17:21:44	ABW MHD
CRL	17:24:01	17:24:46	SHN PAD
CRL	17:26:09	17:26:54	ABW HRW
CRL	17:29:08	17:29:53	SHN PAD
CRL	17:30:59	17:31:44	ABW PAD
CRL	17:33:24	17:34:09	SHN MHD
CRL	17:36:11	17:36:56	ABW WD
CRL	17:39:03	17:39:48	SHN PAD
CRL	17:41:27	17:42:12	ABW HRW
CRL	17:43:57	17:44:42	SHN PAD
CRL	17:45:57	17:46:42	ABW PAD
CRL	17:48:36	17:49:21	SHN PAD
CRL	17:51:48	17:52:33	ABW MHD
CRL	17:53:38	17:54:23	SHN PAD
CRL	17:56:06	17:56:51	ABW HRW
CRL	17:58:41	17:59:26	SHN PAD
CRL	18:01:17	18:02:02	ABW PAD
CRL	18:03:59	18:04:44	SHN MHD
CRL	18:06:04	18:06:49	ABW WD
CRL	18:08:32	18:09:17	SHN PAD
CRL	18:11:13	18:11:58	ABW HRW
CRL	18:13:36	18:14:21	SHN PAD
CRL	18:16:33	18:17:18	ABW PAD
CRL	18:19:18	18:20:03	SHN PAD
CRL	18:21:00	18:21:45	ABW MHD
CRL	18:23:32	18:24:17	SHN PAD
CRL	18:26:40	18:27:25	ABW HRW
CRL	18:28:51	18:29:36	SHN PAD
CRL	18:31:30	18:32:15	ABW PAD
CRL	18:33:39	18:34:24	SHN MHD
CRL	18:36:10	18:36:55	ABW WD
CRL	18:38:26	18:39:11	SHN PAD
CRL	18:41:02	18:41:47	ABW HRW
CRL	18:43:55	18:44:40	SHN PAD
CRL	18:46:37	18:47:22	ABW PAD
CRL	18:48:25	18:49:10	SHN PAD
CRL	18:51:09	18:51:54	ABW MHD
CRL	18:53:24	18:54:09	SHN PAD
CRL	18:55:55	18:56:40	ABW HRW
CRL	18:58:34	18:59:19	SHN PAD

Descriptive Stats	
Peak Period	PM Peak
Future Year	2026
Trains Per Hour	24

07:00 to 10:00			
CRL	72	100.00%	10 81
		0.00%	
<b>Total</b>	<b>72</b>		

07:00 to 08:00			
CRL	24	100.00%	10 33
		0.00%	
<b>Total</b>	<b>24</b>		

08:00 to 09:00			
CRL	24	100.00%	34 57
		0.00%	
<b>Total</b>	<b>24</b>		

09:00 to 10:00			
CRL	24	100.00%	58 81
		0.00%	
<b>Total</b>	<b>24</b>		

Learning Legal Document

BOND STREET

Crossrail EB Platform - AM Peak - 2026 - 24 TPH

Descriptive Stats

Peak Period	AM Peak
Future Year	2026
Trains Per Hour	24

07:00 to 10:00

SBS10-SBS81		10	81
CRL	72	100.00%	
		0.00%	
<b>Total</b>	<b>72</b>		

07:00 to 08:00

SBS10-SBS33		10	33
CRL	24	100.00%	
		0.00%	
<b>Total</b>	<b>24</b>		

08:00 to 09:00

SBS34-SBS57		34	57
CRL	24	100.00%	
		0.00%	
<b>Total</b>	<b>24</b>		

09:00 to 10:00

SBS34-SBS81		58	81
CRL	24	100.00%	
		0.00%	
<b>Total</b>	<b>24</b>		

			Origin	Destination
CRL	07:01:58	07:02:43	PAD	ABW
CRL	07:04:51	07:05:36	MHD	SHN
CRL	07:06:50	07:07:35	WD	ABW
CRL	07:09:14	07:09:59	PAD	SHN
CRL	07:11:52	07:12:37	HRW	ABW
CRL	07:14:18	07:15:03	PAD	SHN
CRL	07:16:46	07:17:31	PAD	ABW
CRL	07:19:17	07:20:02	PAD	SHN
CRL	07:21:44	07:22:29	MHD	ABW
CRL	07:24:27	07:25:12	PAD	SHN
CRL	07:27:11	07:27:56	HRW	ABW
CRL	07:29:37	07:30:22	PAD	SHN
CRL	07:32:19	07:33:04	PAD	ABW
CRL	07:34:31	07:35:16	MHD	SHN
CRL	07:37:05	07:37:50	WD	ABW
CRL	07:39:15	07:40:00	PAD	SHN
CRL	07:42:19	07:43:04	HRW	ABW
CRL	07:44:15	07:45:00	PAD	SHN
CRL	07:46:52	07:47:37	PAD	ABW
CRL	07:49:41	07:50:26	PAD	SHN
CRL	07:52:07	07:52:52	MHD	ABW
CRL	07:54:31	07:55:16	PAD	SHN
CRL	07:57:15	07:58:00	HRW	ABW
CRL	07:59:16	08:00:01	PAD	SHN
CRL	08:01:52	08:02:37	PAD	ABW
CRL	08:04:51	08:05:36	MHD	SHN
CRL	08:06:52	08:07:37	WD	ABW
CRL	08:09:15	08:10:00	PAD	SHN
CRL	08:11:56	08:12:41	HRW	ABW
CRL	08:14:19	08:15:04	PAD	SHN
CRL	08:16:48	08:17:33	PAD	ABW
CRL	08:19:30	08:20:15	PAD	SHN
CRL	08:21:46	08:22:31	MHD	ABW
CRL	08:24:19	08:25:04	PAD	SHN
CRL	08:26:54	08:27:39	HRW	ABW
CRL	08:29:24	08:30:09	PAD	SHN
CRL	08:31:45	08:32:30	PAD	ABW
CRL	08:34:18	08:35:03	MHD	SHN
CRL	08:37:04	08:37:49	WD	ABW
CRL	08:39:43	08:40:28	PAD	SHN
CRL	08:42:19	08:43:04	HRW	ABW
CRL	08:44:14	08:44:59	PAD	SHN
CRL	08:47:22	08:48:07	PAD	ABW
CRL	08:49:18	08:50:03	PAD	SHN
CRL	08:52:02	08:52:47	MHD	ABW
CRL	08:54:37	08:55:22	PAD	SHN
CRL	08:57:07	08:57:52	HRW	ABW
CRL	08:59:20	09:00:05	PAD	SHN
CRL	09:01:53	09:02:38	PAD	ABW
CRL	09:04:22	09:05:07	MHD	SHN
CRL	09:06:55	09:07:40	WD	ABW
CRL	09:09:28	09:10:13	PAD	SHN
CRL	09:11:46	09:12:31	HRW	ABW
CRL	09:14:19	09:15:04	PAD	SHN
CRL	09:17:10	09:17:55	PAD	ABW
CRL	09:19:46	09:20:31	PAD	SHN
CRL	09:21:55	09:22:40	MHD	ABW
CRL	09:24:18	09:25:03	PAD	SHN
CRL	09:27:01	09:27:46	HRW	ABW
CRL	09:29:23	09:30:08	PAD	SHN
CRL	09:31:54	09:32:39	PAD	ABW
CRL	09:34:37	09:35:22	MHD	SHN
CRL	09:36:57	09:37:42	WD	ABW
CRL	09:39:39	09:40:24	PAD	SHN
CRL	09:41:46	09:42:31	HRW	ABW
CRL	09:44:13	09:44:58	PAD	SHN
CRL	09:46:46	09:47:31	PAD	ABW
CRL	09:49:26	09:50:11	PAD	SHN
CRL	09:51:52	09:52:37	MHD	ABW
CRL	09:54:17	09:55:02	PAD	SHN
CRL	09:56:48	09:57:33	HRW	ABW
CRL	09:59:14	09:59:59	PAD	SHN

BOND STREET

Crossrail EB Platform - PM Peak - 2026 - 24 TPH

Descriptive Stats

Peak Period	PM Peak
Future Year	2026
Trains Per Hour	24

07:00 to 10:00

SNS10-SNS81		10	81
CRL	72	100.00%	
	0	0.00%	
<b>Total</b>	<b>72</b>		

07:00 to 08:00

SNS10-SNS33		10	33
CRL	24	100.00%	
	0	0.00%	
<b>Total</b>	<b>24</b>		

08:00 to 09:00

SNS34-SNS57		34	57
CRL	24	100.00%	
	0	0.00%	
<b>Total</b>	<b>24</b>		

09:00 to 10:00

SNS58-SNS81		58	81
CRL	24	100.00%	
	0	0.00%	
<b>Total</b>	<b>24</b>		

			Origin	Destination
CRL	16:01:58	16:02:43	HRW	ABW
CRL	16:04:51	16:05:36	PAD	SHN
CRL	16:06:50	16:07:35	PAD	ABW
CRL	16:09:14	16:09:59	PAD	SHN
CRL	16:11:52	16:12:37	MHD	ABW
CRL	16:14:18	16:15:03	PAD	SHN
CRL	16:16:46	16:17:31	HRW	ABW
CRL	16:19:17	16:20:02	PAD	SHN
CRL	16:21:44	16:22:29	PAD	ABW
CRL	16:24:27	16:25:12	MHD	SHN
CRL	16:27:11	16:27:56	WDR	ABW
CRL	16:29:37	16:30:22	PAD	SHN
CRL	16:32:19	16:33:04	HRW	ABW
CRL	16:34:31	16:35:16	PAD	SHN
CRL	16:37:05	16:37:50	PAD	ABW
CRL	16:39:15	16:40:00	PAD	SHN
CRL	16:42:19	16:43:04	MHD	ABW
CRL	16:44:15	16:45:00	PAD	SHN
CRL	16:46:52	16:47:37	HRW	ABW
CRL	16:49:41	16:50:26	PAD	SHN
CRL	16:52:07	16:52:52	PAD	ABW
CRL	16:54:31	16:55:16	MHD	SHN
CRL	16:57:15	16:58:00	WDR	ABW
CRL	16:59:16	17:00:01	PAD	SHN
CRL	17:01:52	17:02:37	HRW	ABW
CRL	17:04:51	17:05:36	PAD	SHN
CRL	17:06:52	17:07:37	PAD	ABW
CRL	17:09:15	17:10:00	PAD	SHN
CRL	17:11:56	17:12:41	MHD	ABW
CRL	17:14:19	17:15:04	PAD	SHN
CRL	17:16:48	17:17:33	HRW	ABW
CRL	17:19:30	17:20:15	PAD	SHN
CRL	17:21:46	17:22:31	PAD	ABW
CRL	17:24:19	17:25:04	MHD	SHN
CRL	17:26:54	17:27:39	WDR	ABW
CRL	17:29:24	17:30:09	PAD	SHN
CRL	17:31:45	17:32:30	HRW	ABW
CRL	17:34:18	17:35:03	PAD	SHN
CRL	17:37:04	17:37:49	PAD	ABW
CRL	17:39:43	17:40:28	PAD	SHN
CRL	17:42:19	17:43:04	MHD	ABW
CRL	17:44:14	17:44:59	PAD	SHN
CRL	17:47:22	17:48:07	HRW	ABW
CRL	17:49:18	17:50:03	PAD	SHN
CRL	17:52:02	17:52:47	PAD	ABW
CRL	17:54:37	17:55:22	MHD	SHN
CRL	17:57:07	17:57:52	WDR	ABW
CRL	17:59:20	18:00:05	PAD	SHN
CRL	18:01:53	18:02:38	HRW	ABW
CRL	18:04:22	18:05:07	PAD	SHN
CRL	18:06:55	18:07:40	PAD	ABW
CRL	18:09:28	18:10:13	PAD	SHN
CRL	18:11:46	18:12:31	MHD	ABW
CRL	18:14:19	18:15:04	PAD	SHN
CRL	18:17:10	18:17:55	HRW	ABW
CRL	18:19:46	18:20:31	PAD	SHN
CRL	18:21:55	18:22:40	PAD	ABW
CRL	18:24:18	18:25:03	MHD	SHN
CRL	18:27:01	18:27:46	WDR	ABW
CRL	18:29:23	18:30:08	PAD	SHN
CRL	18:31:54	18:32:39	HRW	ABW
CRL	18:34:37	18:35:22	PAD	SHN
CRL	18:36:57	18:37:42	PAD	ABW
CRL	18:39:39	18:40:24	PAD	SHN
CRL	18:41:46	18:42:31	MHD	ABW
CRL	18:44:13	18:44:58	PAD	SHN
CRL	18:46:46	18:47:31	HRW	ABW
CRL	18:49:26	18:50:11	PAD	SHN
CRL	18:51:52	18:52:37	PAD	ABW
CRL	18:54:17	18:55:02	MHD	SHN
CRL	18:56:48	18:57:33	WDR	ABW
CRL	18:59:14	18:59:59	PAD	SHN

RODS2008

	0700-0715	0715-0730	0730-0745	0745-0800	0800-0815	0815-0830	0830-0845	0845-0900	0900-0915	0915-0930	0930-0945	0945-1000	total
BOND STREET T H	68	86	108	131	160	188	207	210	210	211	217	220	2016
BOND STREET EXITS	0	0	0	0	0	0	0	0	0	0	0	0	0
BOND STREET CENTRAL WB	205	286	384	476	555	665	790	861	809	691	574	492	6788
BOND STREET CENTRAL EB	186	249	319	389	465	552	618	617	547	457	380	321	5100
BOND STREET JUBILEE NB	309	438	600	742	858	1001	1154	1223	1137	956	781	658	9857
BOND STREET JUBILEE SB	285	400	527	651	791	944	1054	1047	927	767	626	515	8534

BOND STREET TH	3.37%	4.27%	5.36%	6.50%	7.94%	9.33%	10.27%	10.42%	10.42%	10.47%	10.76%	10.91%
BOND STREET CENTRAL WB	3.02%	4.21%	5.66%	7.01%	8.18%	9.80%	11.64%	12.68%	11.92%	10.18%	8.46%	7.25%
BOND STREET CENTRAL EB	3.65%	4.88%	6.25%	7.63%	9.12%	10.82%	12.12%	12.10%	10.73%	8.96%	7.45%	6.29%
BOND STREET JUBILEE NB	3.13%	4.44%	6.09%	7.53%	8.70%	10.16%	11.71%	12.41%	11.53%	9.70%	7.92%	6.68%
BOND STREET JUBILEE SB	3.34%	4.69%	6.18%	7.63%	9.27%	11.06%	12.35%	12.27%	10.86%	8.99%	7.34%	6.03%

Proxy Required.....

CRL WB	3.02%	4.21%	5.66%	7.01%	8.18%	9.80%	11.64%	12.68%	11.92%	10.18%	8.46%	7.25%
CRL EB	3.65%	4.88%	6.25%	7.63%	9.12%	10.82%	12.12%	12.10%	10.73%	8.96%	7.45%	6.29%

Learning Legacy Document



**Appendix B – PM Peak 2026 Cover Sheet**

Learning Legacy Document

<u>List of Input Assumptions</u>	<u>CRL</u>	<u>LU</u>
1. CAD (Extent of Model)	Y	Y
2. TPH	Y	Y
3. Escalator Config.		
4. Gateline Config.		
5. Ticketing		
6. PRM Routings and Rules		
7. Non-PRM Routings		
8. One-Way System Elements		
9. CRL Adit Usage	Y	Y
10. CRL Timetable	Y	Y
11. CRL Cancelled Train Logic		
12. LU Timetable		
13. NR / Other Timetable		
14. Constraining Alighters Logic	Y	Y
15. Constraining Boarders Logic		
16. Boarding Profiles (CRL)	Y	Y
17. Boarding Profiles (LU / Other)		
18. Alighting Profiles (CRL)	Y	Y
19. Alighting Profiles (LU / Other)		
20. Boarding Logic	Y	Y
21. Dwell Time Logic	Y	Y
22. 15 Minute Profiling	Y	Y
23. TPH broken up into 15 minute periods	Y	Y
24. 15 Minute Demand to Train Services	Y	Y
25. B & A Percentages		
26. Accuracy of Seams		

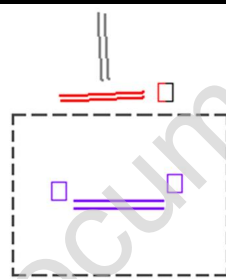
Version Control for 'ACS Bond Street CRL Complex (2026PM)'

Version Number	Date	Comments/Changes	Submitted by	Model Builder File Name (if applicable)
v1	20/05/2010	<b>Sent from Robert Duff (LU) to Nick Gavrielides (CRL) to be passed on to each respective Framework Consultant.</b> Assumption 4: Ticketing is still outstanding (FDC's informed to proceed with whatever's in their current model), Assumption 11: Cancelled Train Logic is to be determined when the perfect timetable set-up spreadsheets are sent back to CRL by the FDC, Assumption 15: In line with the Cancelled Train timetable amendments due to be undertaken by CRL, a Step by Step Boarding Constraint Guide still needs to be completed by CRL. The Train Load Percentages in Assumption 25 will need to be filled in once the correct cancelled train has been determined.	Robert Duff (LU)	N/A
v1	18/08/2010	Correction to tab 1, cell BX35, Train capacity changed from 1500 to 1700	Victoria Ng	N/A
v2	06/10/2010	Sent from C132 to Crossrail pedestrian modelling team	Christine Palmer (WSP)	Bond St PM Sept 2010 For Report.LGM
v3	22/11/2010	A meeting between LUL, C132 and Crossrail on 10th November 2010 was held to discuss the issues highlighted in the model audit. Following this meeting a list of actions was completed by LUL for C132 to incorporate into the models.	Christine Palmer (WSP)	Bond St PM 2026 Nov 2010 For Report.LGM
v4	17/06/2011	Following a series of model runs between December 2010 and June 2011 on 16th June 2011 C132 presented a compliant PM 2026 model to CR and LUL this is was also documented in report number C132-WSP-T3-RGN-C125-50004. This includes the following changes since the last model was issued to CR/LU. It now includes, changed escalator configurations from platform levels to WTH and ETH, updated Intermediate level design, increased number of ticket gates at ETH, revised train stopping position and boarding profiles and Non PRM's using WAGs.	Christine Palmer (WSP)	Bond St PM 2026_Issued June 2011.LGM
v5	26/07/2011	Following the November Audit the following changes have been made to the Cover sheet: CAD Updated to Stage E CAD for Davies Street and Intermediate Level ( <b>see sheet 1</b> ) Escalator configurations changed to 2 Up 1 Down for both ETH and WTH ( <b>see sheet 3</b> ) Increased number of ticket gates at Davies Street and Hanover Square ( <b>see sheet 4</b> ) Non PRM's now can use WAG's at Hanover Square ( <b>see sheet 6</b> ) Eastbound train stopping position moved westwards and revised boarding profiles issued by Crossrail on 18/04/11 used ( <b>see sheet 16</b> ) Revised Bond Street PM Peak demand added into the <b>BDS 2026 Demand worksheet</b>	Christine Palmer (WSP)	Bond St PM 2026_Issued July 2011.LGM
v6	19/08/2011	Finalised for Issue with Final Report - updated train position diagram added to sheet 3. Revised reference to CPFR on sheet 2 from CPFR 4 to 5.	Christine Palmer (WSP)	Bond St PM 2026_Issued August 2011.LGM



List of Input Assumptions	CRL	LU
1. CAD (Extent of Model)	Y	Y
2. TPH	Y	Y
3. Escalator Config.	Y	Y
4. Gateline Config.	Y	Y
5. Ticketing	Y	Y
6. PRM Routings and Rules	Y	Y
7. Non-PRM Routings	Y	Y
8. One-Way System Elements	Y	Y
9. CRL Adit Usage	Y	Y
10. CRL Timetable	Y	Y
11. CRL Cancelled Train Logic	Y	Y
12. LU Timetable	Y	Y
13. NR / Other Timetable	Y	Y
14. Constraining Alighters Logic	Y	Y
15. Constraining Boarders Logic	Y	Y
16. Boarding Profiles (CRL)	Y	Y
17. Boarding Profiles (LU / Other)	Y	Y
18. Alighting Profiles (CRL)	Y	Y
19. Alighting Profiles (LU / Other)	Y	Y
20. Boarding Logic	Y	Y
21. Dwell Time Logic	Y	Y
22. 15 Minute Profiling	Y	Y
23. TPH broken up into 15 minute periods	Y	Y
24. 15 Minute Demand to Train Services	Y	Y
25. B & A Percentages	Y	Y
26. Accuracy of Seams	Y	Y

INPUT 1: CAD (Extent of Model)



Ticket Halls:	Existing?	New?	Platforms:	Existing?	New?
Davies Street CRL Ticket Hall		Y	CRL WB		Y
Hanover Square CRL Ticket Hall		Y	CRL EB		Y

Outside Extent of Model but accurate flows captured?:  
**Yes demand profile from LUL's Legion model to Bond Street Crossrail has been adopted.**

(Please see #26 for further details)

Source of CAD:	
Drawing Number Davies Street Ticket Hall	C132-WSP-A-DDA-C125-01100.dwg
Drawing Number Hanover Square Ticket Hall	C132-WSP-A-DDA-C125-52101.dwg
Drawing Number Intermediate Level	C132-WSP-A-DDA-C125-01120.dwg
Drawing Number LUL Passageway Link	C132-WSP-A-DMA-C125-03130.dwg
Drawing Number Platform Level	C132-WSP-A-DMA-C125-03150.dwg
Drawing Number Passageway to Western lifts	C132-WSP-A-DMA-C125-01150.dwg
Drawing Number Passageway to Eastern lifts	C132-WSP-A-DMA-C125-02150.dwg

Rolling Stock CAD:	Total Number of Carriages	Configuration	T: No. of Doors	DM: No. of Doors	UNDM: No. of Doors	Assumed Capacity
CRL	10	DM-T-T-T-T-T-T-T-T-DM	3D	2D	-	1700 <sup>a</sup>

References:  
 (a) As stated in CPFR v4.0  
 CRL Rolling Stock: D = 1600mm

Key CRL Platform Dimensions:	
CRL WB Platform Width	4.5m (N.B. Usable Width (from PED to when backwall height reaches 2.4m))
CRL EB Platform Width	4.5m (N.B. Usable Width (from PED to when backwall height reaches 2.4m))

List of Input Assumptions

CRL LU

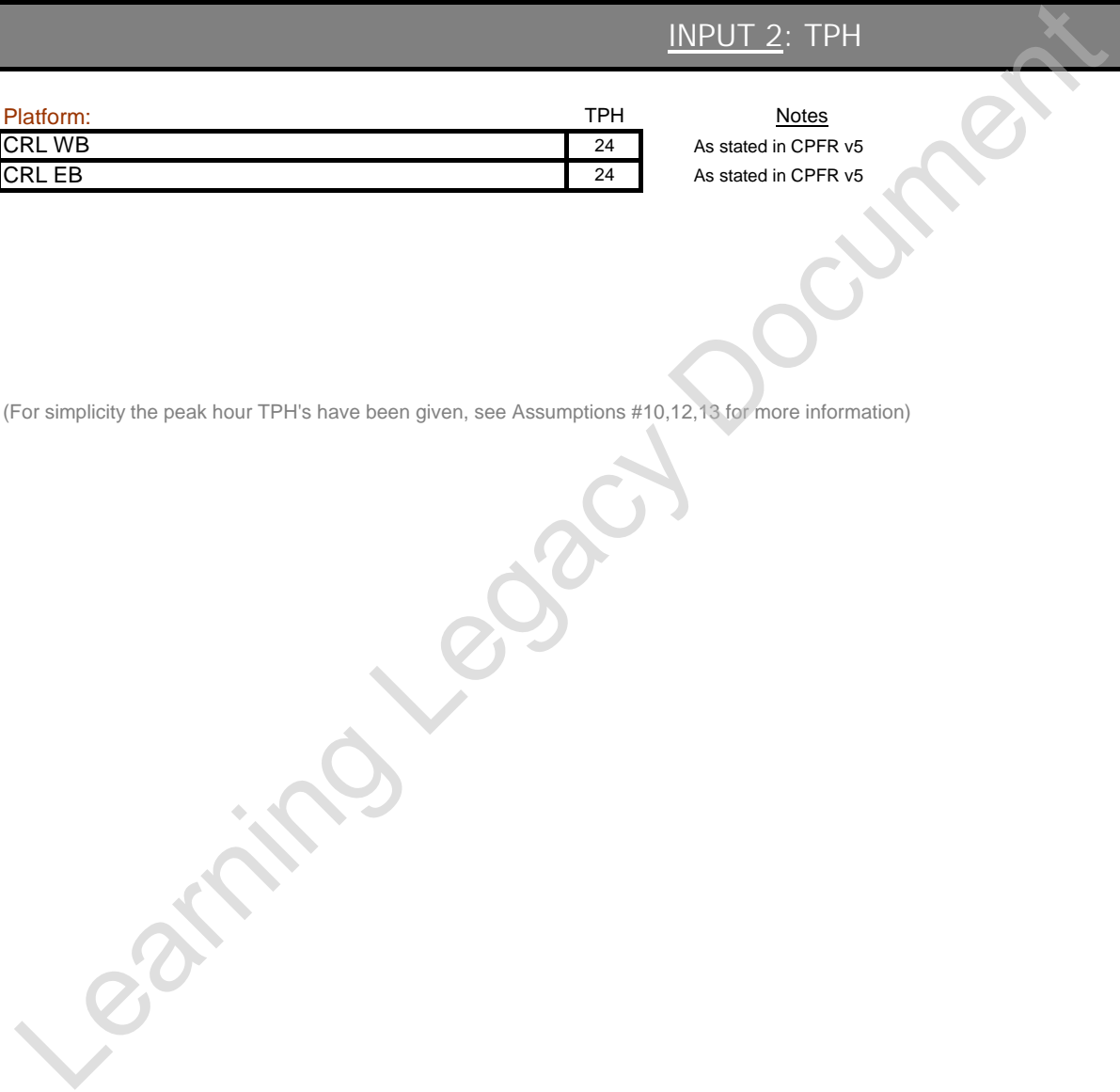
INPUT 2: TPH

1. CAD (Extent of Model)	Y	Y
2. TPH	Y	Y
3. Escalator Config.		
4. Gateline Config.		
5. Ticketing		
6. PRM Routings and Rules		
7. Non-PRM Routings		
8. One-Way System Elements		
9. CRL Adit Usage	Y	Y
10. CRL Timetable	Y	Y
11. CRL Cancelled Train Logic		
12. LU Timetable		
13. NR / Other Timetable		
14. Constraining Alighters Logic	Y	Y
15. Constraining Boarders Logic		
16. Boarding Profiles (CRL)	Y	Y
17. Boarding Profiles (LU / Other)		
18. Alighting Profiles (CRL)	Y	Y
19. Alighting Profiles (LU / Other)		
20. Boarding Logic	Y	Y
21. Dwell Time Logic	Y	Y
22. 15 Minute Profiling	Y	Y
23. TPH broken up into 15 minute periods	Y	Y
24. 15 Minute Demand to Train Services	Y	Y
25. B & A Percentages		
26. Accuracy of Seams		

Platform:	TPH
CRL WB	24
CRL EB	24

Notes  
As stated in CPFR v5  
As stated in CPFR v5

(For simplicity the peak hour TPH's have been given, see Assumptions #10,12,13 for more information)



List of Input Assumptions

CRL	LU
Y	Y
Y	Y
Y	Y
Y	Y
Y	Y
Y	Y
Y	Y
Y	Y
Y	Y
Y	Y
Y	Y
Y	Y
Y	Y

1. CAD (Extent of Model)
2. TPH
3. Escalator Config.
4. Gateline Config.
5. Ticketing
6. PRM Routings and Rules
7. Non-PRM Routings
8. One-Way System Elements
9. CRL Adit Usage
10. CRL Timetable
11. CRL Cancelled Train Logic
12. LU Timetable
13. NR / Other Timetable
14. Constraining Alighters Logic
15. Constraining Boarders Logic
16. Boarding Profiles (CRL)
17. Boarding Profiles (LU / Other)
18. Alighting Profiles (CRL)
19. Alighting Profiles (LU / Other)
20. Boarding Logic
21. Dwell Time Logic
22. 15 Minute Profiling
23. TPH broken up into 15 minute periods
24. 15 Minute Demand to Train Services
25. B & A Percentages
26. Accuracy of Seams

INPUT 3: Escalator Configurations

Upper Concourse to/from CRL Platforms:

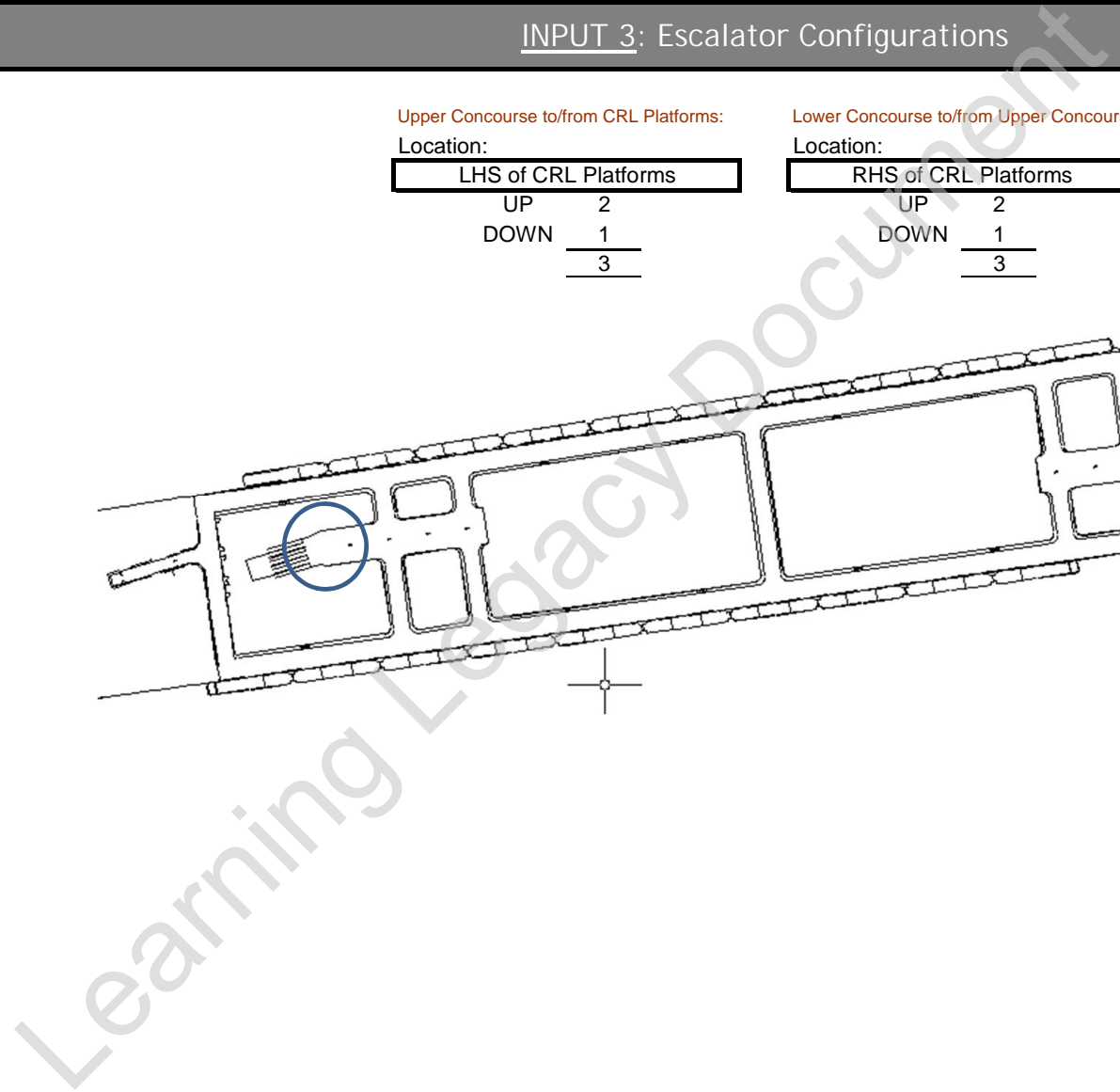
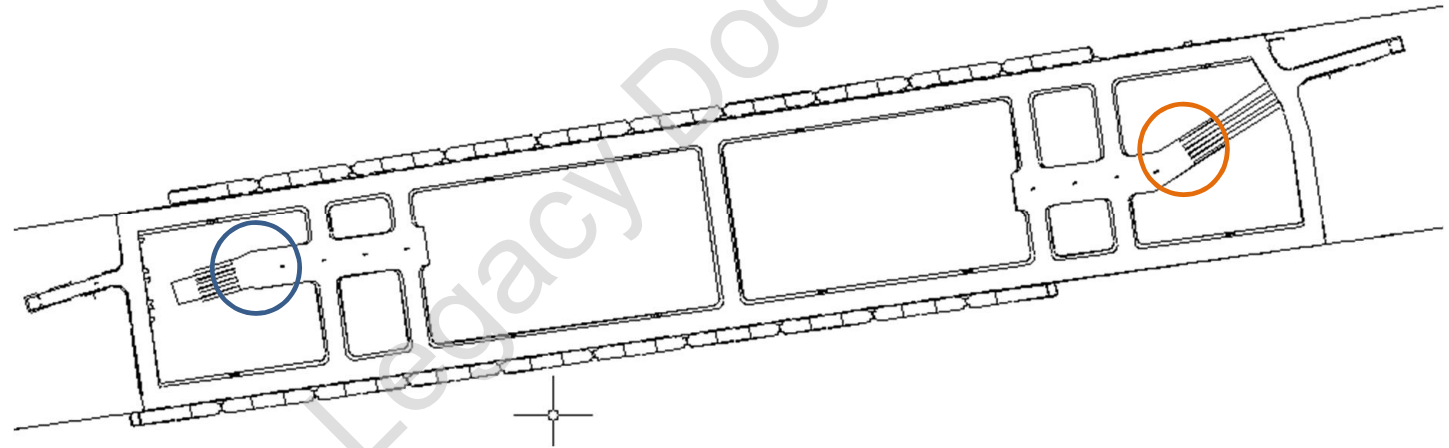
Location: **LHS of CRL Platforms**

UP	2
DOWN	1
	<hr/>
	3

Lower Concourse to/from Upper Concourse:

Location: **RHS of CRL Platforms**

UP	2
DOWN	1
	<hr/>
	3



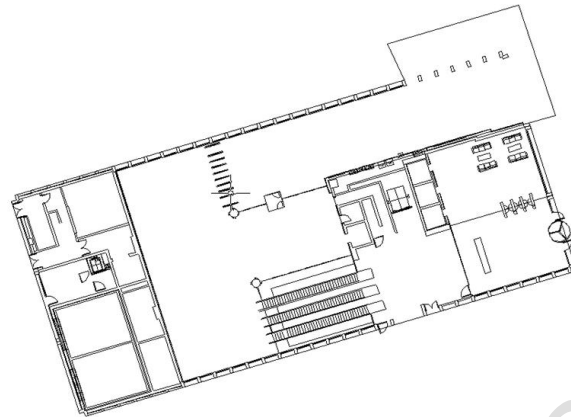
List of Input Assumptions

CRL LU

1. CAD (Extent of Model)	Y	Y
2. TPH	Y	Y
3. Escalator Config.		
4. Gateline Config.		
5. Ticketing		
6. PRM Routings and Rules		
7. Non-PRM Routings		
8. One-Way System Elements		
9. CRL Adit Usage	Y	Y
10. CRL Timetable	Y	Y
11. CRL Cancelled Train Logic		
12. LU Timetable		
13. NR / Other Timetable		
14. Constraining Alighters Logic	Y	Y
15. Constraining Boarders Logic		
16. Boarding Profiles (CRL)	Y	Y
17. Boarding Profiles (LU / Other)		
18. Alighting Profiles (CRL)	Y	Y
19. Alighting Profiles (LU / Other)		
20. Boarding Logic	Y	Y
21. Dwell Time Logic	Y	Y
22. 15 Minute Profiling	Y	Y
23. TPH broken up into 15 minute periods	Y	Y
24. 15 Minute Demand to Train Services	Y	Y
25. B & A Percentages		
26. Accuracy of Seams		

INPUT 4: Gateline Configurations

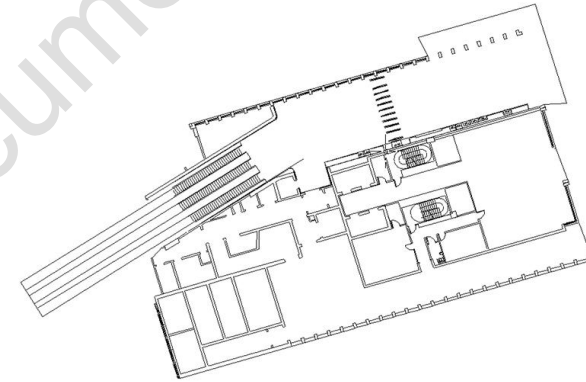
Davies Street CRL Ticket Hall



Davies Street

No. Inwards UTS Gates	4
No. Outwards UTS Gate	3
	<u>7</u>
No. Inwards WAGS	1
No. Outwards WAGS	1
No. Bi-Directional WAGS	0
	<u>2</u>

Hanover Square CRL Ticket Hall



Hanover Square

No. Inwards UTS Gates	3
No. Outwards UTS Gate	5
	<u>8</u>
No. Inwards WAGS	1
No. Outwards WAGS	1
No. Bi-Directional WAGS	0
	<u>2</u>

Ticket capacity 33 pax/,min or 1.8 sec delay (taken from LUL Station Modelling with LEGION Best Practice Guide)

Ticket capacity 25 pax/,min or 2.4 sec delay - as per text below

(\*) There is the requirement that on any single gateline there should be two uni-directional WAGS positioned at either side of the gateline

Bi-Directional WAGS are not favourable since they provide a throughput of just 7 pax/min compared to 25 pax/min of their uni-directional counterparts.

(\*\*) For any new ticket hall, the adequacy of the number of gates (proposed or current) should be backed up using the SPSG Gateline Formula.

List of Input Assumptions

CRL LU

INPUT 5: Ticketing

- 1. CAD (Extent of Model) Y Y
- 2. TPH Y Y
- 3. Escalator Config. Y Y
- 4. Gatetime Config. Y Y
- 5. Ticketing Y Y
- 6. PRM Routings and Rules Y Y
- 7. Non-PRM Routings Y Y
- 8. One-Way System Elements Y Y
- 9. CRL Adit Usage Y Y
- 10. CRL Timetable Y Y
- 11. CRL Cancelled Train Logic Y Y
- 12. LU Timetable Y Y
- 13. NR / Other Timetable Y Y
- 14. Constraining Alighters Logic Y Y
- 15. Constraining Boarders Logic Y Y
- 16. Boarding Profiles (CRL) Y Y
- 17. Boarding Profiles (LU / Other) Y Y
- 18. Alighting Profiles (CRL) Y Y
- 19. Alighting Profiles (LU / Other) Y Y
- 20. Boarding Logic Y Y
- 21. Dwell Time Logic Y Y
- 22. 15 Minute Profiling Y Y
- 23. TPH broken up into 15 minute periods Y Y
- 24. 15 Minute Demand to Train Services Y Y
- 25. B & A Percentages Y Y
- 26. Accuracy of Seams Y Y

Davies Street CRL Ticket Hall:

Number of CRL TVM POM's 3 Transaction Time assumed: 20, 45, 75  
 Number of CRL TOP POM's 2 Transaction Time assumed: 10, 15, 30  
 % of accessing CRL/LU passengers that are assumed to require CRL POM's 6%

Hanover Square CRL Ticket Hall:

Number of CRL TVM POM's 3 Transaction Time assumed: 20, 45, 75  
 Number of CRL TOP POM's 2 Transaction Time assumed: 10, 15, 30  
 % of accessing CRL/LU passengers that are assumed to require CRL POM's 6%

LU LBPG

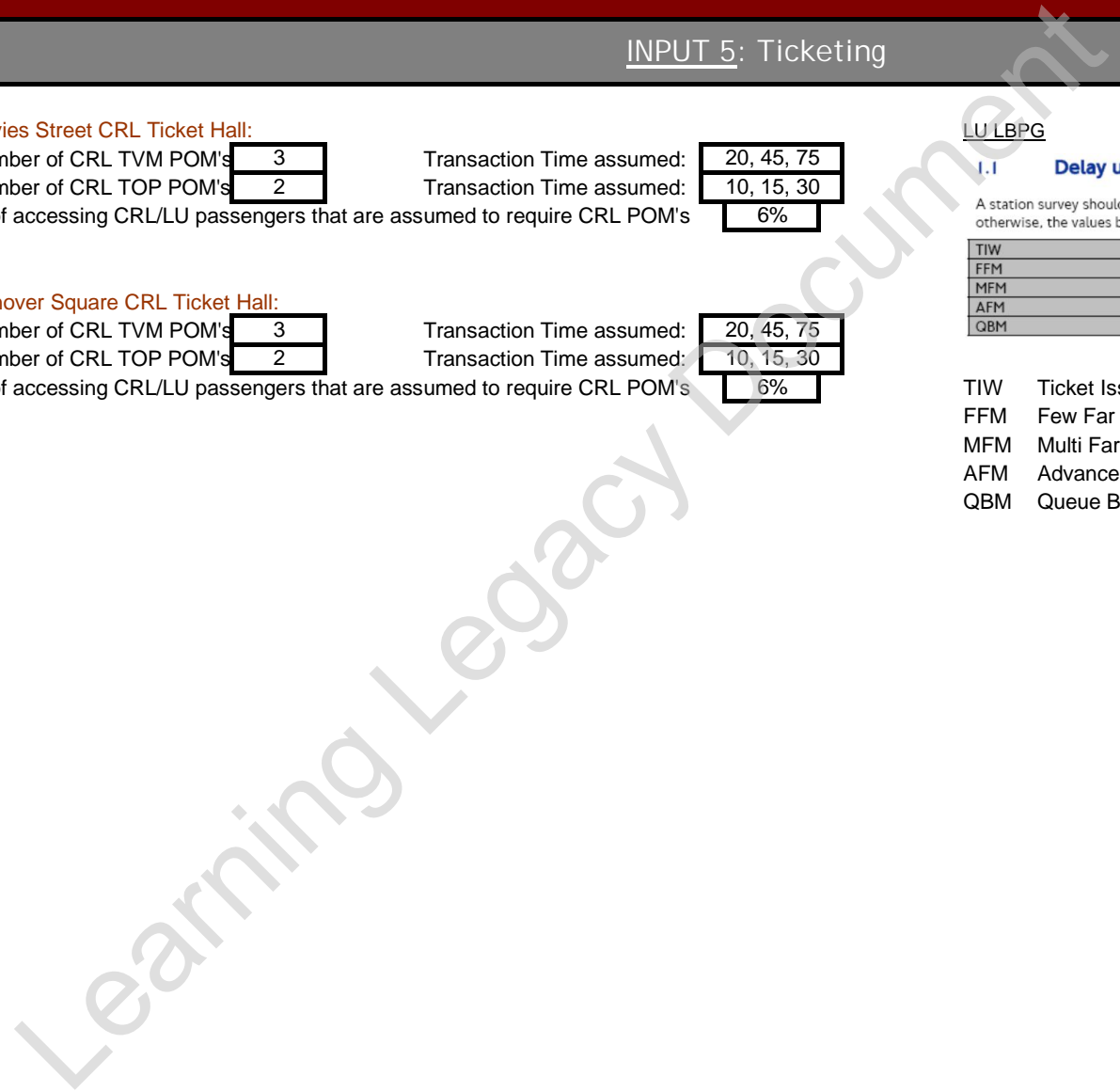
1.1 Delay used on ticket issuing facilities

A station survey should be conducted to collect the relevant information; otherwise, the values below may be used. All figures in seconds.

TIW	Variable: 20 (min), 40 (mean), 90 (max)
FFM	10, 15, 30
MFM	20, 45, 70
AFM	15, 20, 30
QBM	15, 40, 70

Source: LU LBPG (July 2009, Vol 3, Pg 1)

- TIW Ticket Issuing Window
- FFM Few Far Machine
- MFM Multi Fare Machine
- AFM Advanced Fare Machine
- QBM Queue Buster Machine



List of Input Assumptions

CRL	LU
Y	Y
Y	Y
Y	Y
Y	Y
Y	Y
Y	Y
Y	Y
Y	Y
Y	Y
Y	Y
Y	Y
Y	Y
Y	Y
Y	Y

1. CAD (Extent of Model)
2. TPH
3. Escalator Config.
4. Gateline Config.
5. Ticketing
6. PRM Routings and Rules
7. Non-PRM Routings
8. One-Way System Elements
9. CRL Adit Usage
10. CRL Timetable
11. CRL Cancelled Train Logic
12. LU Timetable
13. NR / Other Timetable
14. Constraining Alighters Logic
15. Constraining Boarders Logic
16. Boarding Profiles (CRL)
17. Boarding Profiles (LU / Other)
18. Alighting Profiles (CRL)
19. Alighting Profiles (LU / Other)
20. Boarding Logic
21. Dwell Time Logic
22. 15 Minute Profiling
23. TPH broken up into 15 minute periods
24. 15 Minute Demand to Train Services
25. B & A Percentages
26. Accuracy of Seams

INPUT 6: PRM Routings and Rules

**WAG Rules:**

The following PRM's get sent through the WAG:

PRM_A	Y
PRM_B	Y
PRM_C	Y
PRM_D	Y
PRM_E	Y
Non PRMs (Hanover Square ONLY)	Y

**Lift Rules:**

The following PRM's get sent to the Lift:

PRM_A	Y
PRM_B	Y
PRM_C	N
PRM_D	Y
PRM_E	Y

**Speeds and Sizes:**

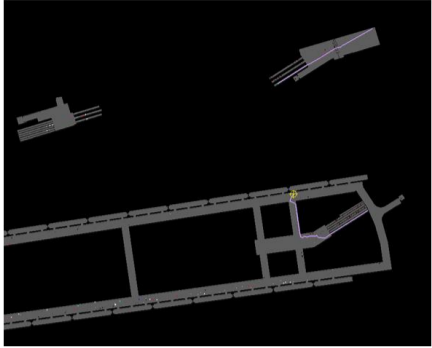
Type	Diameter	Speed	
PRM_A	Large	0.58m/s	[Fixed]
PRM_B	Small	0.80m/s	[Fixed]
PRM_C	Medium	1.53m/s	[Normal Distribution]
PRM_D	Large	1.32m/s	[Normal Distribution]
PRM_E	Large	1.37m/s	[Normal Distribution]

List of Input Assumptions

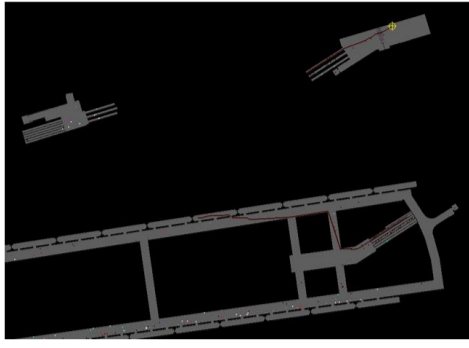
	CRL	LU
1. CAD (Extent of Model)	Y	Y
2. TPH	Y	Y
3. Escalator Config.		
4. Gateline Config.		
5. Ticketing		
6. PRM Routings and Rules		
7. Non-PRM Routings		
8. One-Way System Elements		
9. CRL Adit Usage	Y	Y
10. CRL Timetable	Y	Y
11. CRL Cancelled Train Logic		
12. LU Timetable		
13. NR / Other Timetable		
14. Constraining Alighters Logic	Y	Y
15. Constraining Boarders Logic		
16. Boarding Profiles (CRL)	Y	Y
17. Boarding Profiles (LU / Other)		
18. Alighting Profiles (CRL)	Y	Y
19. Alighting Profiles (LU / Other)		
20. Boarding Logic	Y	Y
21. Dwell Time Logic	Y	Y
22. 15 Minute Profiling	Y	Y
23. TPH broken up into 15 minute periods	Y	Y
24. 15 Minute Demand to Train Services	Y	Y
25. B & A Percentages		
26. Accuracy of Seams		

INPUT 7: Non-PRM Routings

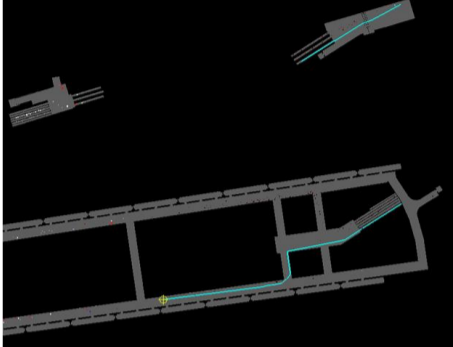
HS -> CRL EB:



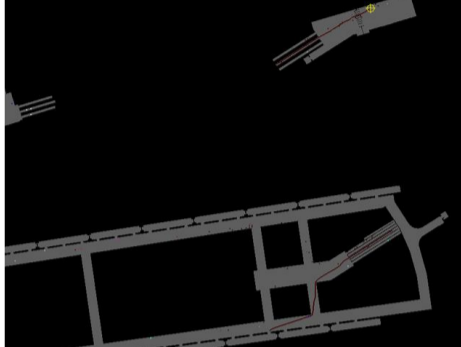
CRL EB -> HS:



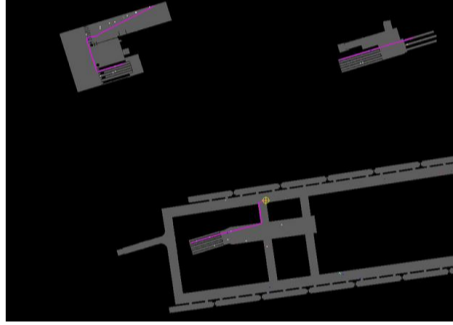
HS -> CRL WB:



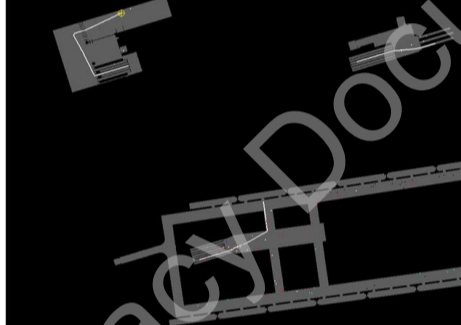
CRL WB -> HS:



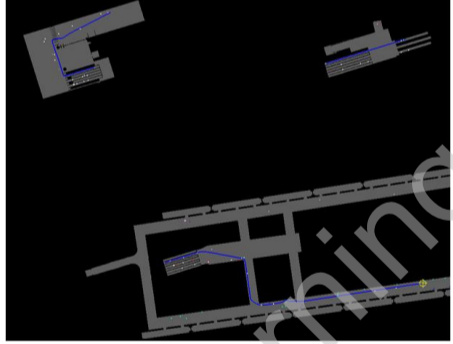
DS -> CRL EB:



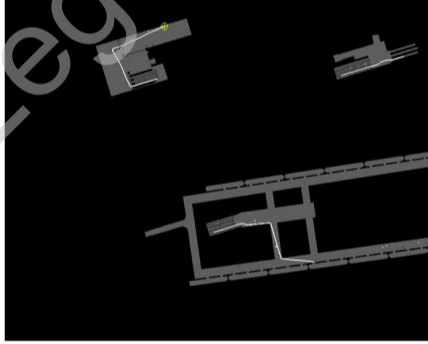
CRL EB -> DS:



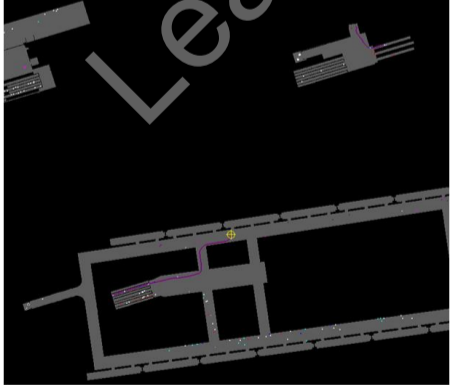
DS -> CRL WB:



CRL WB -> DS:



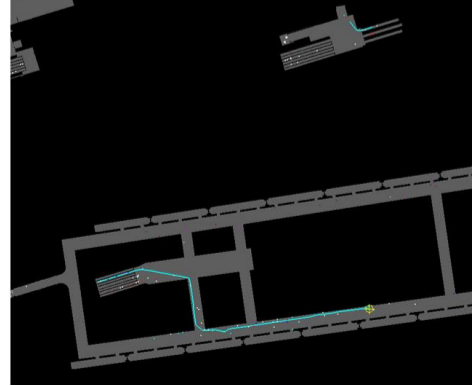
LUL -> CRL EB:



CRL EB -> LUL:



LUL -> CRL WB:



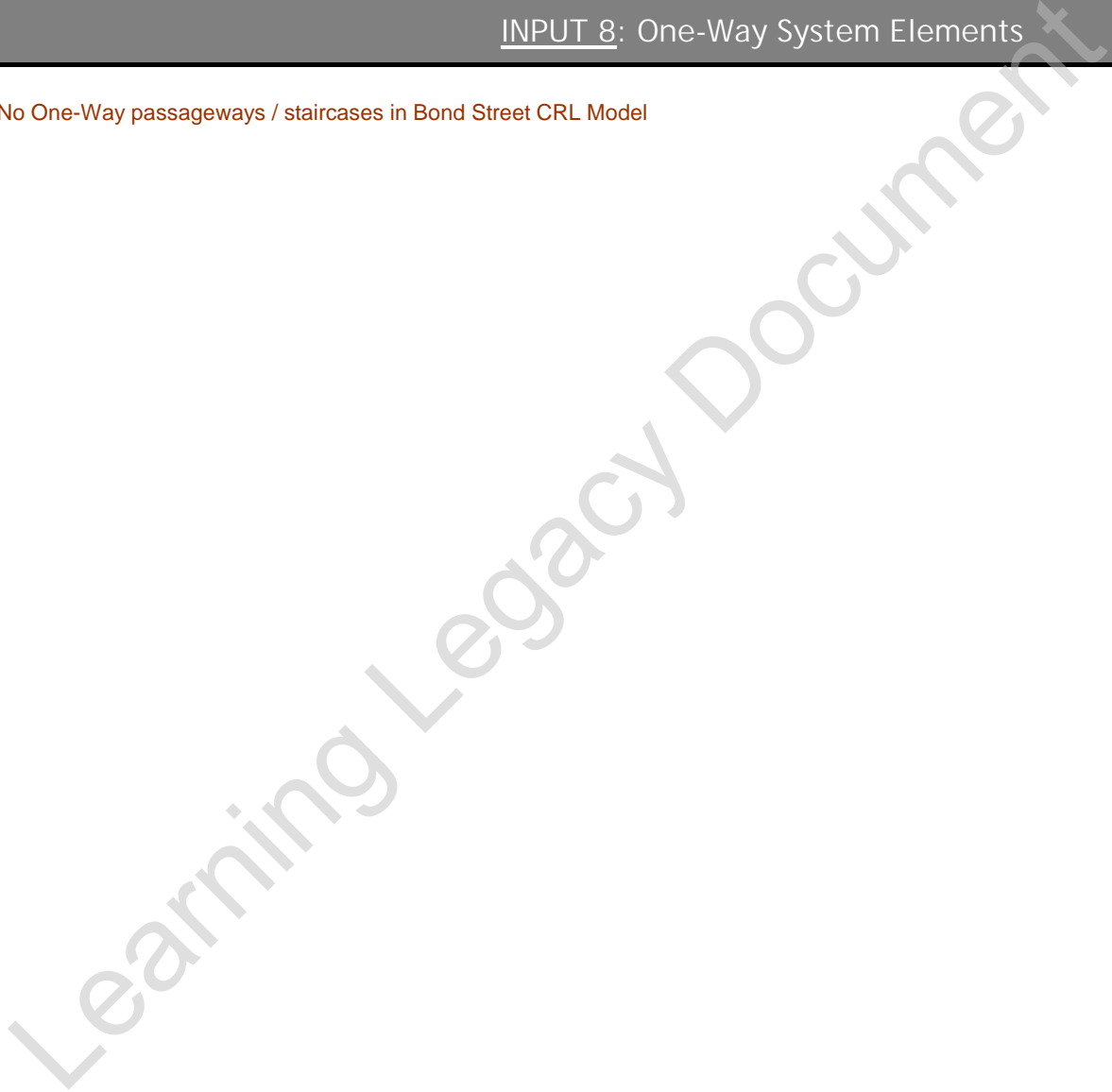
CRL WB -> LUL:



INPUT 8: One-Way System Elements

List of Input Assumptions	CRL	LU
1. CAD (Extent of Model)	Y	Y
2. TPH	Y	Y
3. Escalator Config.		
4. Gateline Config.		
5. Ticketing		
6. PRM Routings and Rules		
7. Non-PRM Routings		
8. One-Way System Elements		
9. CRL Adit Usage	Y	Y
10. CRL Timetable	Y	Y
11. CRL Cancelled Train Logic		
12. LU Timetable		
13. NR / Other Timetable		
14. Constraining Alighters Logic	Y	Y
15. Constraining Boarders Logic		
16. Boarding Profiles (CRL)	Y	Y
17. Boarding Profiles (LU / Other)		
18. Alighting Profiles (CRL)	Y	Y
19. Alighting Profiles (LU / Other)		
20. Boarding Logic	Y	Y
21. Dwell Time Logic	Y	Y
22. 15 Minute Profiling	Y	Y
23. TPH broken up into 15 minute periods	Y	Y
24. 15 Minute Demand to Train Services	Y	Y
25. B & A Percentages		
26. Accuracy of Seams		

No One-Way passageways / staircases in Bond Street CRL Model





List of Input Assumptions

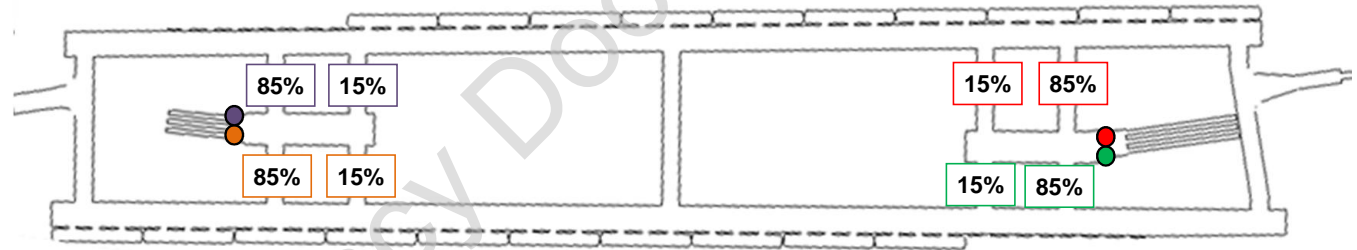
CRL LU

1. CAD (Extent of Model)	Y	Y
2. TPH	Y	Y
3. Escalator Config.		
4. Gateline Config.		
5. Ticketing		
6. PRM Routings and Rules		
7. Non-PRM Routings		
8. One-Way System Elements		
9. CRL Adit Usage	Y	Y
10. CRL Timetable	Y	Y
11. CRL Cancelled Train Logic		
12. LU Timetable		
13. NR / Other Timetable		
14. Constraining Alighters Logic	Y	Y
15. Constraining Boarders Logic		
16. Boarding Profiles (CRL)	Y	Y
17. Boarding Profiles (LU / Other)		
18. Alighting Profiles (CRL)	Y	Y
19. Alighting Profiles (LU / Other)		
20. Boarding Logic	Y	Y
21. Dwell Time Logic	Y	Y
22. 15 Minute Profiling	Y	Y
23. TPH broken up into 15 minute periods	If	Y
24. 15 Minute Demand to Train Services	Y	Y
25. B & A Percentages		
26. Accuracy of Seams		

INPUT 9: CRL Adit Usage

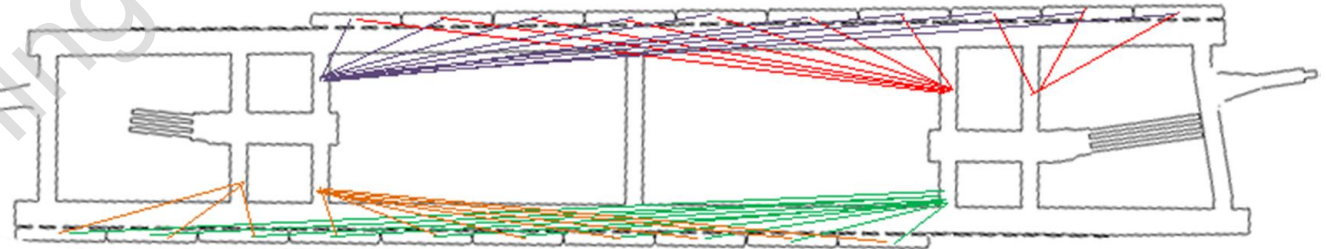
Boarders:

Strict % split assumption as detailed in below diagram.  
Specific Rules will exist for certain types of PRM's (see Assumption #6 for more information)



Alighters:

Logic Rule: Passengers as soon as they step off the train aim for the lower escalator concourse on the western/eastern end of the platforms and apply 'Shortest Distance' logic to determine the adit to be used. If this leads to unrealistic crowding in one adit while leaving the next adit along under-utilised, a reassignment to the less utilised adit would be appropriate.  
Certain Rules will exist for certain types of PRM's (see Assumption #6 for more information).



NB. Train Stopping positions (10 cars) may not necessarily be as depicted in the indicative diagrams above. The chief purpose of the diagrams are to illustratively highlight the logic to be applied in these areas.

List of Input Assumptions

CRL LU

INPUT 10: CRL Timetable

1. CAD (Extent of Model)	Y	Y
2. TPH	Y	Y
3. Escalator Config.		
4. Gateline Config.		
5. Ticketing		
6. PRM Routings and Rules		
7. Non-PRM Routings		
8. One-Way System Elements		
9. CRL Adit Usage	Y	Y
10. CRL Timetable	Y	Y
11. CRL Cancelled Train Logic		
12. LU Timetable		
13. NR / Other Timetable		
14. Constraining Alighters Logic	Y	Y
15. Constraining Boarders Logic		
16. Boarding Profiles (CRL)	Y	Y
17. Boarding Profiles (LU / Other)		
18. Alighting Profiles (CRL)	Y	Y
19. Alighting Profiles (LU / Other)		
20. Boarding Logic	Y	Y
21. Dwell Time Logic	Y	Y
22. 15 Minute Profiling	Y	Y
23. TPH broken up into 15 minute periods	Y	Y
24. 15 Minute Demand to Train Services	Y	Y
25. B & A Percentages		
26. Accuracy of Seams		

CRL WB Platform - Descriptive Summary

Origin	TPH 7-8	TPH 8-9	TPH 9-10	Total 7-10
Shenfield	12	12	12	36
Abbey Wood	12	12	12	36
	24	24	24	72

Destination	TPH 7-8	TPH 8-9	TPH 9-10	Total 7-10
Paddington	14	14	14	42
Heathrow	4	4	4	12
West Drayton	2	2	2	6
Maidenhead	4	4	4	12
	24	24	24	72

CRL EB Platform - Descriptive Summary

Origin	TPH 7-8	TPH 8-9	TPH 9-10	Total 7-10
Paddington	14	14	14	42
Heathrow	4	4	4	12
West Drayton	2	2	2	6
Maidenhead	4	4	4	12
	24	24	24	72

Destination	TPH 7-8	TPH 8-9	TPH 9-10	Total 7-10
Shenfield	12	12	12	36
Abbey Wood	12	12	12	36
	24	24	24	72

List of Input Assumptions

CRL LU

1. CAD (Extent of Model)	Y	Y
2. TPH	Y	Y
3. Escalator Config.		
4. Gateline Config.		
5. Ticketing		
6. PRM Routings and Rules		
7. Non-PRM Routings		
8. One-Way System Elements		
9. CRL Adit Usage	Y	Y
10. CRL Timetable	Y	Y
11. CRL Cancelled Train Logic		
12. LU Timetable		
13. NR / Other Timetable		
14. Constraining Alighters Logic	Y	Y
15. Constraining Boarders Logic		
16. Boarding Profiles (CRL)	Y	Y
17. Boarding Profiles (LU / Other)		
18. Alighting Profiles (CRL)	Y	Y
19. Alighting Profiles (LU / Other)		
20. Boarding Logic	Y	Y
21. Dwell Time Logic	Y	Y
22. 15 Minute Profiling	Y	Y
23. TPH broken up into 15 minute periods	Y	Y
24. 15 Minute Demand to Train Services	Y	Y
25. B & A Percentages		
26. Accuracy of Seams		

INPUT 11: CRL Cancelled Train Logic

CRL WB Platform - Descriptive Summary

Origin	TPH 7-8	TPH 8-9	TPH 9-10	Total 7-10
Shenfield	12	12	12	36
Abbey Wood	12	12	12	36
	24	24	24	72

Destination	TPH 7-8	TPH 8-9	TPH 9-10	Total 7-10
Paddington	14	14	14	42
Heathrow	4	4	4	12
West Drayton	2	2	2	6
Maidenhead	4	4	4	12
	24	24	24	72

CRL EB Platform - Descriptive Summary

Origin	TPH 7-8	TPH 8-9	TPH 9-10	Total 7-10
Paddington	14	13	14	41
Heathrow	4	4	4	12
West Drayton	2	4	2	8
Maidenhead	4	4	4	12
	24	25	24	73

Destination	TPH 7-8	TPH 8-9	TPH 9-10	Total 7-10
Shenfield	12	11	12	35
Abbey Wood	12	12	12	36
	24	23	24	71

Cancellation Logic:

During the peak 15 minutes one train will be cancelled on one Crossrail platform. The train will be cancelled on the platform with the highest volume of passengers. If there are more alighters than boarders (usually the case in the AM peak) then the train with the most alighters will be cancelled, and similarly if there are more boarders than alighters (usually the case in the PM peak) then the train with the most popular destination will be cancelled.

In the cancelled train scenario, there will be more passengers than normal waiting on the platform and therefore more passengers trying to board the next train. In some cases it might therefore not be possible for all passengers to board the train following the cancelled train. The capacity will be assessed and boarders will be constrained so that capacity is not breached.

In the cancelled train scenario, there will also be more passengers alighting from subsequent trains. Generally the alighters that would have been on the cancelled train will be transferred onto the following trains travelling on the same route. For example, at Whitechapel if a westbound train from Shenfield is cancelled, the alighters that would have been on the cancelled train will be assumed to arrive on the following train from Shenfield. None of these passengers would arrive on trains from Abbey Wood as the line splits at Whitechapel. However, at stations further west, for example Bond Street, in the same situation the alighters from the cancelled train would arrive on the two following trains, some on the next train from Abbey Wood and some on the next train from Shenfield. This is because the passengers getting on between Whitechapel and Bond Street could come on the next train following the cancelled train, which would be from Abbey Wood, but passengers getting on east of Whitechapel would have to board the next train from Shenfield. The split between the two trains will be based on the general split from Shenfield and Abbey Wood.

In some cases, this approach would cause the number of alighters on the trains following the cancelled train to exceed capacity. This will be assessed and the number of alighters per train will be limited so as not to exceed the total capacity. For example, at Whitechapel if the cancelled train from Shenfield would have had 300 alighters, the initial calculation would put 600 alighters on the following train from Shenfield. However, if the percentage of the train load alighting at Whitechapel is 30% then the maximum possible number of alighters would be 30% of 1700 (max train load) = 510. Therefore, the train from Shenfield following the cancelled train would be limited to 510 alighters as opposed to 600. The excess of 90 would be transferred to the following train from Shenfield, i.e. two trains (from Shenfield) after the cancelled train.

Where station designs on the platform area are not symmetrical it will be necessary to cancel a train on the least popular platform to ensure designs have been sufficiently tested.

List of Input Assumptions

CRL LU

INPUT 12: LU Timetable

1. CAD (Extent of Model)	Y	Y
2. TPH	Y	Y
3. Escalator Config.		
4. Gateline Config.		
5. Ticketing		
6. PRM Routings and Rules		
7. Non-PRM Routings		
8. One-Way System Elements		
9. CRL Adit Usage	Y	Y
10. CRL Timetable	Y	Y
11. CRL Cancelled Train Logic		
12. LU Timetable		
13. NR / Other Timetable		
14. Constraining Alighters Logic	Y	Y
15. Constraining Boarders Logic		
16. Boarding Profiles (CRL)	Y	Y
17. Boarding Profiles (LU / Other)		
18. Alighting Profiles (CRL)	Y	Y
19. Alighting Profiles (LU / Other)		
20. Boarding Logic	Y	Y
21. Dwell Time Logic	Y	Y
22. 15 Minute Profiling	Y	Y
23. TPH broken up into 15 minute periods	Y	Y
24. 15 Minute Demand to Train Services	Y	Y
25. B & A Percentages		
26. Accuracy of Seams		

Not relevant for the Bond Street Crossrail Model.

Learning Legacy Document

List of Input Assumptions	CRL	LU	INPUT 13: NR / Other Timetable
1. CAD (Extent of Model)	Y	Y	Not relevant for the Bond Street Crossrail Model.  Learning Legacy Document
2. TPH	Y	Y	
3. Escalator Config.			
4. Gateline Config.			
5. Ticketing			
6. PRM Routings and Rules			
7. Non-PRM Routings			
8. One-Way System Elements			
9. CRL Adit Usage	Y	Y	
10. CRL Timetable	Y	Y	
11. CRL Cancelled Train Logic			
12. LU Timetable			
13. NR / Other Timetable			
14. Constraining Alighters Logic	Y	Y	
15. Constraining Boarders Logic			
16. Boarding Profiles (CRL)	Y	Y	
17. Boarding Profiles (LU / Other)			
18. Alighting Profiles (CRL)	Y	Y	
19. Alighting Profiles (LU / Other)			
20. Boarding Logic	Y	Y	
21. Dwell Time Logic	Y	Y	
22. 15 Minute Profiling	Y	Y	
23. TPH broken up into 15 minute periods	Y	Y	
24. 15 Minute Demand to Train Services	Y	Y	
25. B & A Percentages			
26. Accuracy of Seams			

List of Input Assumptions

CRL	LU
Y	Y
Y	Y
Y	Y
Y	Y
Y	Y
Y	Y
Y	Y
Y	Y
Y	Y
Y	Y
Y	Y
Y	Y
Y	Y

INPUT 14: Constraining Alighters Logic

**Mostly Applicable in AM Peak when there are generally more Alighters than Boarders**

Step 1:

Determine the Peak Fifteen Minutes

[Define: Peak fifteen minutes]

Step 2:

Determine the CRL service in the peak fifteen minutes with the highest number of alighters that will be placed on subsequent trains following a cancellation

[Define: Direction + (from Origin)]

Choose from:

- CRL WB (from Abbey Wood)      CRL EB (from Paddington)
- CRL WB (from Shenfield)      CRL EB (from Maidenhead)
- CRL EB (from Heathrow)
- CRL EB (from West Drayton)

(N.B. Please ensure that the cancelled train is the first appropriate service in the Peak fifteen minutes in question, this will ensure that any effect of a cancellation is sufficiently captured in any congestion plots / outputs from the peak fifteen period in question)

Step 3:

Calculate the maximum number of alighters at any one time from a 'Direction + (from Origin)' service

[Define: Max Number of Alighters]

Step 4:

Calculate the number of alighters displaced from the cancelled train and add these appropriately to the alighters already due on subsequent train(s)

[Define: Revised Alighting Load On Subsequent Train(s)]

Step 5:

- a If Revised Alighting Load On ANY Subsequent Train ≤ Max Number of Alighters then subsequent train Alighting Load = OKAY
- b If Revised Alighting Load On ANY Subsequent Train > Max Number of Alighters then subsequent train Alighting Load = Max Number of Alighters

Step 6:

If Step 5b takes precedence over Step 5a then place [ Revised Alighting Load On Subsequent Train(s) - [Max Number of Alighters] ] excess passengers on further appropriate subsequent trains

$$[Max\ Number\ of\ Alighters] = \frac{\text{Percentage of Trainload from a [Direction + (from Origin)] Service Alighting at Whitechapel}}{\text{Capacity of a CRL Train}}$$

List of Input Assumptions

CRL LU

INPUT 15: Constraining Boarders Logic

1. CAD (Extent of Model)	Y	Y
2. TPH	Y	Y
3. Escalator Config.		
4. Gateline Config.		
5. Ticketing		
6. PRM Routings and Rules		
7. Non-PRM Routings		
8. One-Way System Elements		
9. CRL Adit Usage	Y	Y
10. CRL Timetable	Y	Y
11. CRL Cancelled Train Logic		
12. LU Timetable		
13. NR / Other Timetable		
14. Constraining Alighters Logic	Y	Y
15. Constraining Boarders Logic		
16. Boarding Profiles (CRL)	Y	Y
17. Boarding Profiles (LU / Other)		
18. Alighting Profiles (CRL)	Y	Y
19. Alighting Profiles (LU / Other)		
20. Boarding Logic	Y	Y
21. Dwell Time Logic	Y	Y
22. 15 Minute Profiling	Y	Y
23. TPH broken up into 15 minute periods	Y	Y
24. 15 Minute Demand to Train Services	Y	Y
25. B & A Percentages		
26. Accuracy of Seams		

Mostly Applicable in PM Peak when there are generally more Boarders than Alighters

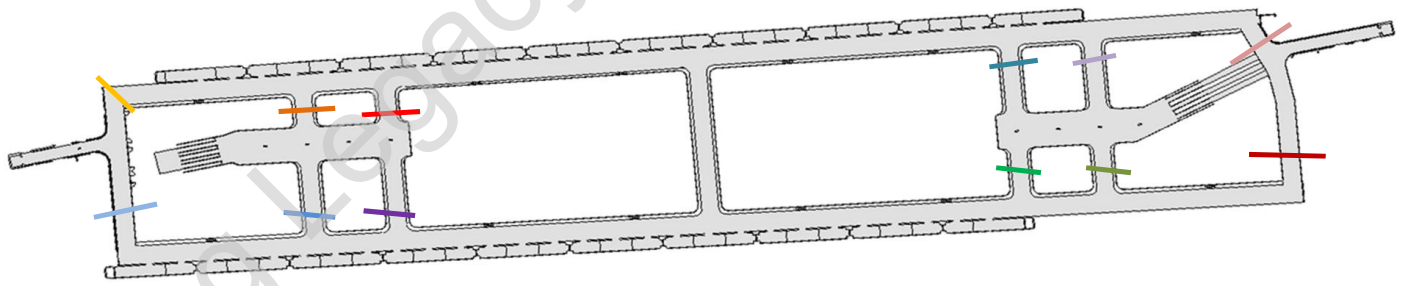
Boarding Logic was provided by Crossrail pedestrian modelling team.

Learning Legacy Document

List of Input Assumptions	CRL	LU
1. CAD (Extent of Model)	Y	Y
2. TPH	Y	Y
3. Escalator Config.		
4. Gateline Config.		
5. Ticketing		
6. PRM Routings and Rules		
7. Non-PRM Routings		
8. One-Way System Elements		
9. CRL Adit Usage	Y	Y
10. CRL Timetable	Y	Y
11. CRL Cancelled Train Logic		
12. LU Timetable		
13. NR / Other Timetable		
14. Constraining Alighters Logic	Y	Y
15. Constraining Boarders Logic		
16. Boarding Profiles (CRL)	Y	Y
17. Boarding Profiles (LU / Other)		
18. Alighting Profiles (CRL)	Y	Y
19. Alighting Profiles (LU / Other)		
20. Boarding Logic	Y	Y
21. Dwell Time Logic	Y	Y
22. 15 Minute Profiling	Y	Y
23. TPH broken up into 15 minute periods	Y	Y
24. 15 Minute Demand to Train Services	Y	Y
25. B & A Percentages		
26. Accuracy of Seams		

INPUT 16: Boarding Profiles (CRL)

CRL EB Platform Entrances										
Car 10	Car 9	Car 8	Car 7	Car 6	Car 5	Car 4	Car 3	Car 2	Car 1	
40.0%	30.0%	20.0%	10.0%	0.0%	0.0%	0.0%	0.0%	0.0%	0.0%	100.0%
14.5%	16.0%	15.0%	14.0%	12.5%	10.0%	8.0%	5.5%	3.5%	1.0%	100.0%
5.0%	12.0%	16.0%	16.0%	15.0%	12.5%	11.0%	7.5%	4.5%	0.5%	100.0%
1.5%	2.5%	4.5%	7.5%	10.5%	12.5%	15.0%	15.0%	16.0%	15.0%	100.0%
1.0%	1.0%	4.0%	7.0%	10.0%	12.0%	14.0%	16.0%	17.0%	18.0%	100.0%
0.0%	0.0%	0.0%	0.0%	0.0%	0.0%	5.0%	17.5%	32.5%	45.0%	100.0%



CRL WB Platform Entrances										
Car 1	Car 2	Car 3	Car 4	Car 5	Car 6	Car 7	Car 8	Car 9	Car 10	
40.0%	30.0%	20.0%	10.0%	0.0%	0.0%	0.0%	0.0%	0.0%	0.0%	100.0%
14.0%	15.0%	15.0%	14.0%	12.0%	10.0%	8.0%	6.0%	4.0%	2.0%	100.0%
4.0%	11.0%	16.0%	16.0%	15.0%	13.0%	11.0%	8.0%	5.0%	1.0%	100.0%
1.0%	1.0%	4.0%	7.0%	10.0%	12.0%	14.0%	16.0%	17.0%	18.0%	100.0%
1.0%	1.0%	4.0%	7.0%	10.0%	12.0%	14.0%	16.0%	17.0%	18.0%	100.0%
0.0%	0.0%	0.0%	0.0%	0.0%	0.0%	5.0%	17.5%	32.5%	45.0%	100.0%



List of Input Assumptions	CRL	LU	INPUT 17: Boarding Profiles (LU / Other)
1. CAD (Extent of Model)	Y	Y	<p>Not relevant for the Bond Street Crossrail Model.</p>
2. TPH	Y	Y	
3. Escalator Config.			
4. Gateline Config.			
5. Ticketing			
6. PRM Routings and Rules			
7. Non-PRM Routings			
8. One-Way System Elements			
9. CRL Adit Usage	Y	Y	
10. CRL Timetable	Y	Y	
11. CRL Cancelled Train Logic			
12. LU Timetable			
13. NR / Other Timetable			
14. Constraining Alighters Logic	Y	Y	
15. Constraining Boarders Logic			
16. Boarding Profiles (CRL)	Y	Y	
17. Boarding Profiles (LU / Other)			
18. Alighting Profiles (CRL)	Y	Y	
19. Alighting Profiles (LU / Other)			
20. Boarding Logic	Y	Y	
21. Dwell Time Logic	Y	Y	
22. 15 Minute Profiling	Y	Y	
23. TPH broken up into 15 minute periods	Y	Y	
24. 15 Minute Demand to Train Services	Y	Y	
25. B & A Percentages			
26. Accuracy of Seams			

Learning Legacy Document

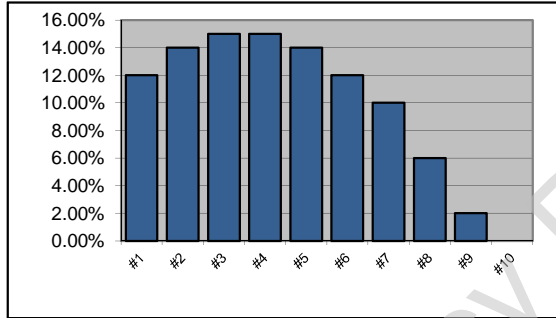
List of Input Assumptions

CRL LU

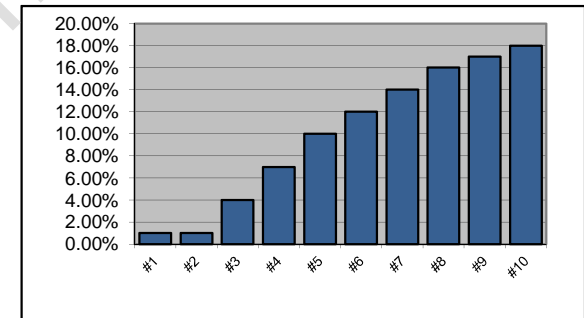
- 1. CAD (Extent of Model) Y Y
- 2. TPH Y Y
- 3. Escalator Config. Y Y
- 4. Gateline Config. Y Y
- 5. Ticketing Y Y
- 6. PRM Routings and Rules Y Y
- 7. Non-PRM Routings Y Y
- 8. One-Way System Elements Y Y
- 9. CRL Adit Usage Y Y
- 10. CRL Timetable Y Y
- 11. CRL Cancelled Train Logic Y Y
- 12. LU Timetable Y Y
- 13. NR / Other Timetable Y Y
- 14. Constraining Alighters Logic Y Y
- 15. Constraining Boarders Logic Y Y
- 16. Boarding Profiles (CRL) Y Y
- 17. Boarding Profiles (LU / Other) Y Y
- 18. Alighting Profiles (CRL) Y Y
- 19. Alighting Profiles (LU / Other) Y Y
- 20. Boarding Logic Y Y
- 21. Dwell Time Logic Y Y
- 22. 15 Minute Profiling Y Y
- 23. TPH broken up into 15 minute periods Y Y
- 24. 15 Minute Demand to Train Services Y Y
- 25. B & A Percentages Y Y
- 26. Accuracy of Seams Y Y

INPUT 18: Alighting Profiles (CRL)

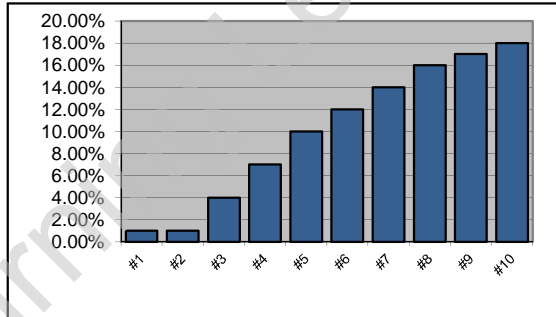
Platform Name	
CRL WB (Davies St)	
Car	%
#1	12.00%
#2	14.00%
#3	15.00%
#4	15.00%
#5	14.00%
#6	12.00%
#7	10.00%
#8	6.00%
#9	2.00%
#10	0.00%
<u>100.00%</u>	



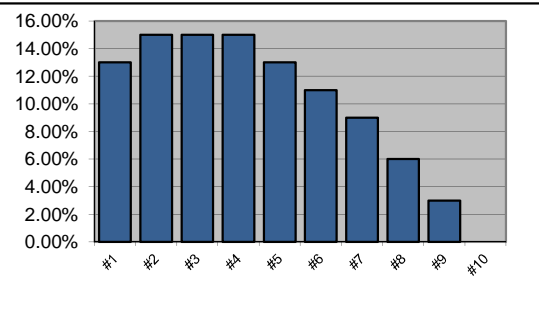
Platform Name	
CRL WB (Hanover Sq)	
Car	%
#1	1.00%
#2	1.00%
#3	4.00%
#4	7.00%
#5	10.00%
#6	12.00%
#7	14.00%
#8	16.00%
#9	17.00%
#10	18.00%
<u>100.00%</u>	



Platform Name	
CRL EB (Davies St)	
Car	%
#1	1.00%
#2	1.00%
#3	4.00%
#4	7.00%
#5	10.00%
#6	12.00%
#7	14.00%
#8	16.00%
#9	17.00%
#10	18.00%
<u>100.00%</u>	



Platform Name	
CRL EB (Hanover Sq)	
Car	%
#1	13.00%
#2	15.00%
#3	15.00%
#4	15.00%
#5	13.00%
#6	11.00%
#7	9.00%
#8	6.00%
#9	3.00%
#10	0.00%
<u>100.00%</u>	



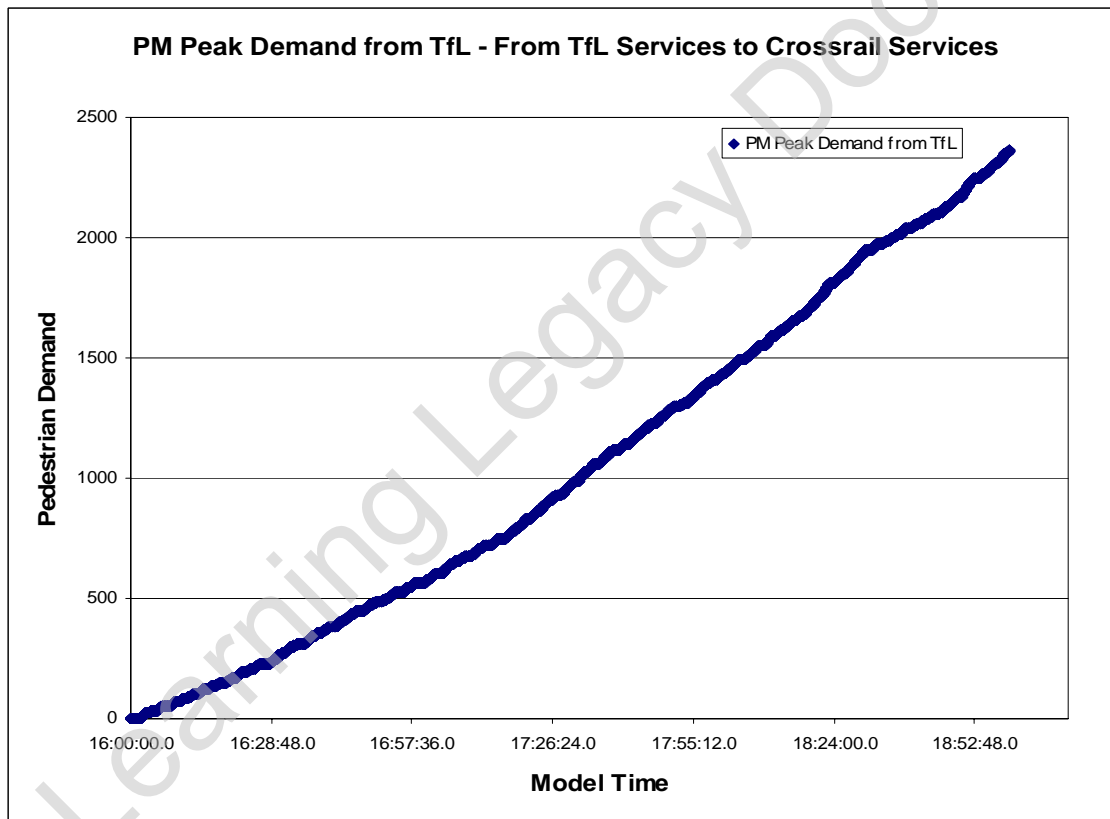
INPUT 19: Alighting Profiles (LU / Other)

List of Input Assumptions	CRL	LU
1. CAD (Extent of Model)	Y	Y
2. TPH	Y	Y
3. Escalator Config.		
4. Gateline Config.		
5. Ticketing		
6. PRM Routings and Rules		
7. Non-PRM Routings		
8. One-Way System Elements		
9. CRL Adit Usage	Y	Y
10. CRL Timetable	Y	Y
11. CRL Cancelled Train Logic		
12. LU Timetable		
13. NR / Other Timetable		
14. Constraining Alighters Logic	Y	Y
15. Constraining Boarders Logic		
16. Boarding Profiles (CRL)	Y	Y
17. Boarding Profiles (LU / Other)		
18. Alighting Profiles (CRL)	Y	Y
19. Alighting Profiles (LU / Other)		
20. Boarding Logic	Y	Y
21. Dwell Time Logic	Y	Y
22. 15 Minute Profiling	Y	Y
23. TPH broken up into 15 minute periods	Y	Y
24. 15 Minute Demand to Train Services	Y	Y
25. B & A Percentages		
26. Accuracy of Seams		

This is the profile of demand provided by LU for the arrival of pedestrians into Bond Street Crossrail from LUL services - This has bveen taken from the Bond Street Upgrade Legion Model. This profile has been used and applied to the predicted demand from the LUL tunnel.

LGM File: I:\BND Bond Street\J090xx Bond Street Modelling Assurance for RUP\BOS XRL 2017 PM\BOS XRL PM 2017\_RevA.lgm

RES File: I:\BND Bond Street\J090xx Bond Street Modelling Assurance for RUP\BOS XRL 2017 PM\BOS XRL PM 2017\_RevA\_Base\_1.res



List of Input Assumptions

CRL LU

INPUT 20: Boarding Logic

1. CAD (Extent of Model)	Y	Y
2. TPH	Y	Y
3. Escalator Config.		
4. Gateline Config.		
5. Ticketing		
6. PRM Routings and Rules		
7. Non-PRM Routings		
8. One-Way System Elements		
9. CRL Adit Usage	Y	Y
10. CRL Timetable	Y	Y
11. CRL Cancelled Train Logic		
12. LU Timetable		
13. NR / Other Timetable		
14. Constraining Alighters Logic	Y	Y
15. Constraining Boarders Logic		
16. Boarding Profiles (CRL)	Y	Y
17. Boarding Profiles (LU / Other)		
18. Alighting Profiles (CRL)	Y	Y
19. Alighting Profiles (LU / Other)		
20. Boarding Logic	Y	Y
21. Dwell Time Logic	Y	Y
22. 15 Minute Profiling	Y	Y
23. TPH broken up into 15 minute periods	Y	Y
24. 15 Minute Demand to Train Services	Y	Y
25. B & A Percentages		
26. Accuracy of Seams		

Focal nodes in the adits distribute passengers to focal nodes placed in the area in front of each carriage. Once stepped inside these carriage focal nodes passengers are evenly distributed to Waiting Zones adjacent to the PEDs for that carriage. All passengers go straight to the PEDs regardless of whether or not they are boarding the next train.

The distribution will be dependent on the adit location in relation to the platform. (See Input Assumption #16 for more details)

XR153Ru

The percentages of boarding passengers having preferences for train services is calculated from Railplan 2026 run:  
(See Input Assumption #25 for more details)

Learning Legacy Document

List of Input Assumptions

CRL LU

INPUT 21: Dwell Time Logic

1. CAD (Extent of Model)	Y	Y
2. TPH	Y	Y
3. Escalator Config.		
4. Gateline Config.		
5. Ticketing		
6. PRM Routings and Rules		
7. Non-PRM Routings		
8. One-Way System Elements		
9. CRL Adit Usage	Y	Y
10. CRL Timetable	Y	Y
11. CRL Cancelled Train Logic		
12. LU Timetable		
13. NR / Other Timetable		
14. Constraining Alighters Logic	Y	Y
15. Constraining Boarders Logic		
16. Boarding Profiles (CRL)	Y	Y
17. Boarding Profiles (LU / Other)		
18. Alighting Profiles (CRL)	Y	Y
19. Alighting Profiles (LU / Other)		
20. Boarding Logic	Y	Y
21. Dwell Time Logic	Y	Y
22. 15 Minute Profiling	Y	Y
23. TPH broken up into 15 minute periods	Y	Y
24. 15 Minute Demand to Train Services	Y	Y
25. B & A Percentages		
26. Accuracy of Seams		

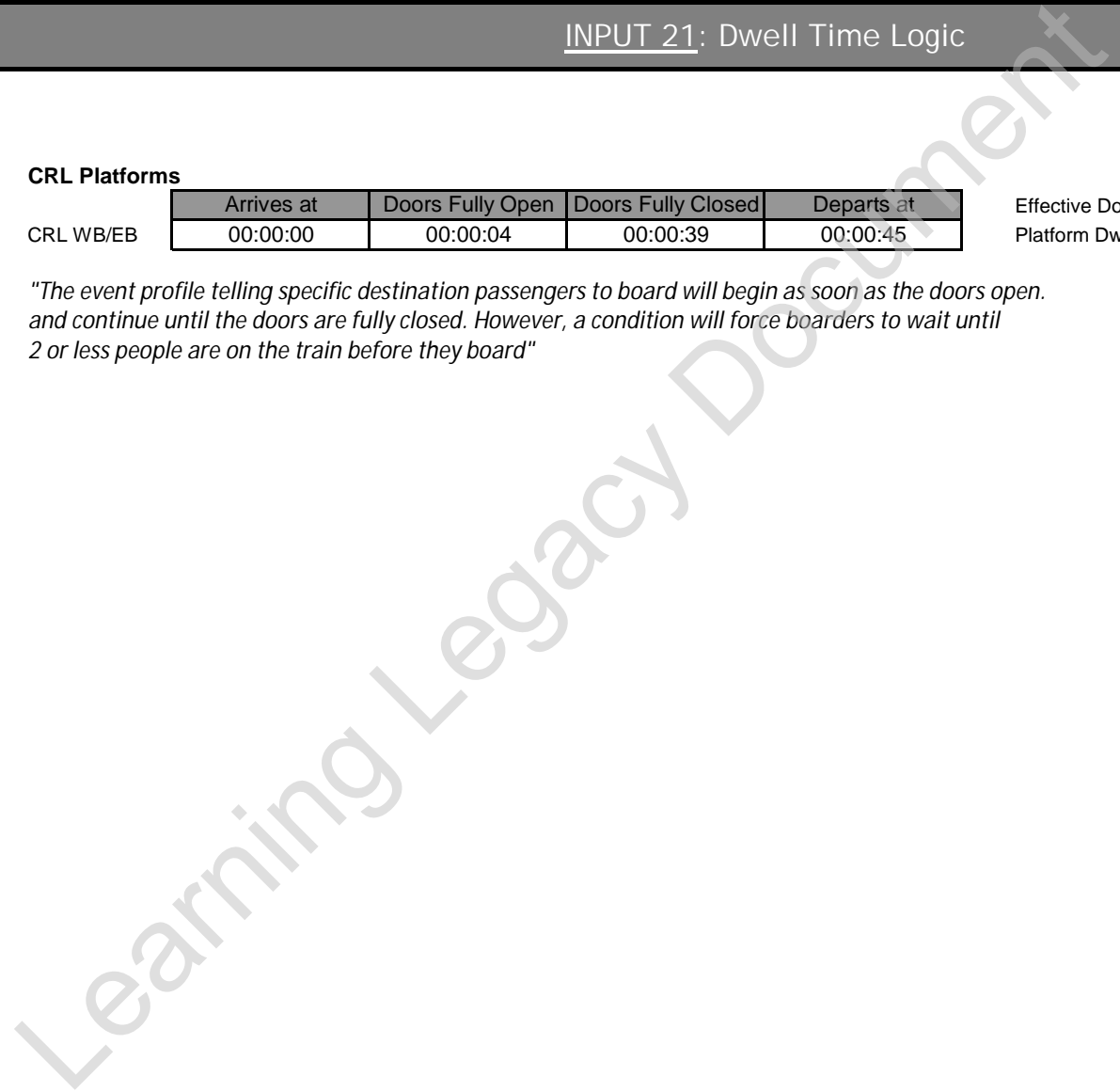
CRL Platforms

	Arrives at	Doors Fully Open	Doors Fully Closed	Departs at
CRL WB/EB	00:00:00	00:00:04	00:00:39	00:00:45

Effective Door Opening Time  
Platform Dwell Time

00:00:35
00:00:45

"The event profile telling specific destination passengers to board will begin as soon as the doors open. and continue until the doors are fully closed. However, a condition will force boarders to wait until 2 or less people are on the train before they board"





List of Input Assumptions

CRL LU

INPUT 23: TPH broken up 15 into minute periods

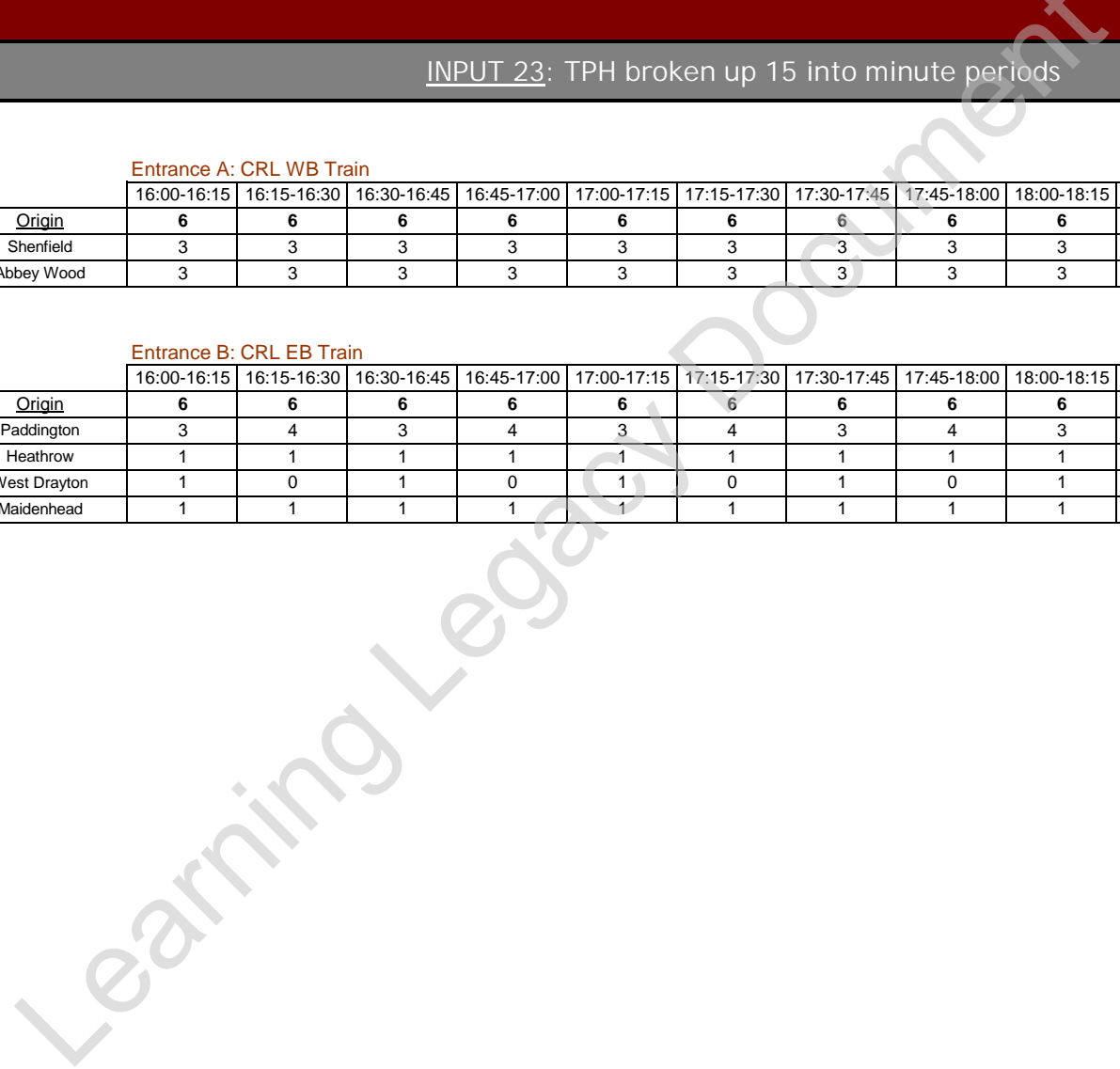
- 1. CAD (Extent of Model) Y Y
- 2. TPH Y Y
- 3. Escalator Config. Y Y
- 4. Gateline Config. Y Y
- 5. Ticketing Y Y
- 6. PRM Routings and Rules Y Y
- 7. Non-PRM Routings Y Y
- 8. One-Way System Elements Y Y
- 9. CRL Adit Usage Y Y
- 10. CRL Timetable Y Y
- 11. CRL Cancelled Train Logic Y Y
- 12. LU Timetable Y Y
- 13. NR / Other Timetable Y Y
- 14. Constraining Alighters Logic Y Y
- 15. Constraining Boarders Logic Y Y
- 16. Boarding Profiles (CRL) Y Y
- 17. Boarding Profiles (LU / Other) Y Y
- 18. Alighting Profiles (CRL) Y Y
- 19. Alighting Profiles (LU / Other) Y Y
- 20. Boarding Logic Y Y
- 21. Dwell Time Logic Y Y
- 22. 15 Minute Profiling Y Y
- 23. TPH broken up into 15 minute periods Y Y
- 24. 15 Minute Demand to Train Services Y Y
- 25. B & A Percentages Y Y
- 26. Accuracy of Seams Y Y

Entrance A: CRL WB Train

	16:00-16:15	16:15-16:30	16:30-16:45	16:45-17:00	17:00-17:15	17:15-17:30	17:30-17:45	17:45-18:00	18:00-18:15	18:15-18:30	18:30-18:45	18:45-19:00
<u>Origin</u>	6	6	6	6	6	6	6	6	6	6	6	6
Shenfield	3	3	3	3	3	3	3	3	3	3	3	3
Abbey Wood	3	3	3	3	3	3	3	3	3	3	3	3

Entrance B: CRL EB Train

	16:00-16:15	16:15-16:30	16:30-16:45	16:45-17:00	17:00-17:15	17:15-17:30	17:30-17:45	17:45-18:00	18:00-18:15	18:15-18:30	18:30-18:45	18:45-19:00
<u>Origin</u>	6	6	6	6	6	6	6	6	6	6	6	6
Paddington	3	4	3	4	3	4	3	4	3	4	3	4
Heathrow	1	1	1	1	1	1	1	1	1	1	1	1
West Drayton	1	0	1	0	1	0	1	0	1	0	1	0
Maidenhead	1	1	1	1	1	1	1	1	1	1	1	1



INPUT 24: 15 Minute Demand to Train Services

List of Input Assumptions

CRL U

- 1. CAD (Extent of Model) Y Y
- 2. TPH Y Y
- 3. Escalator Config. Y
- 4. Gaiteline Config. Y
- 5. Ticketing Y
- 6. PRM Routings and Rules Y
- 7. Non-PRM Routings Y
- 8. One-Way System Elements Y
- 9. CRL Adit Usage Y Y
- 10. CRL Timetable Y Y
- 11. CRL Cancelled Train Logic Y
- 12. LU Timetable Y
- 13. NR / Other Timetable Y
- 14. Constraining Alighters Logic Y Y
- 15. Constraining Boarders Logic Y
- 16. Boarding Profiles (CRL) Y Y
- 17. Boarding Profiles (LU / Other) Y
- 18. Alighting Profiles (CRL) Y Y
- 19. Alighting Profiles (LU / Other) Y
- 20. Boarding Logic Y Y
- 21. Dwell Time Logic Y Y
- 22. 15 Minute Profiling Y Y
- 23. TPH broken up into 15 minute periods Y Y
- 24. 15 Minute Demand to Train Services Y Y
- 25. B & A Percentages Y
- 26. Accuracy of Seams Y

Entrance A: CRL WB Train

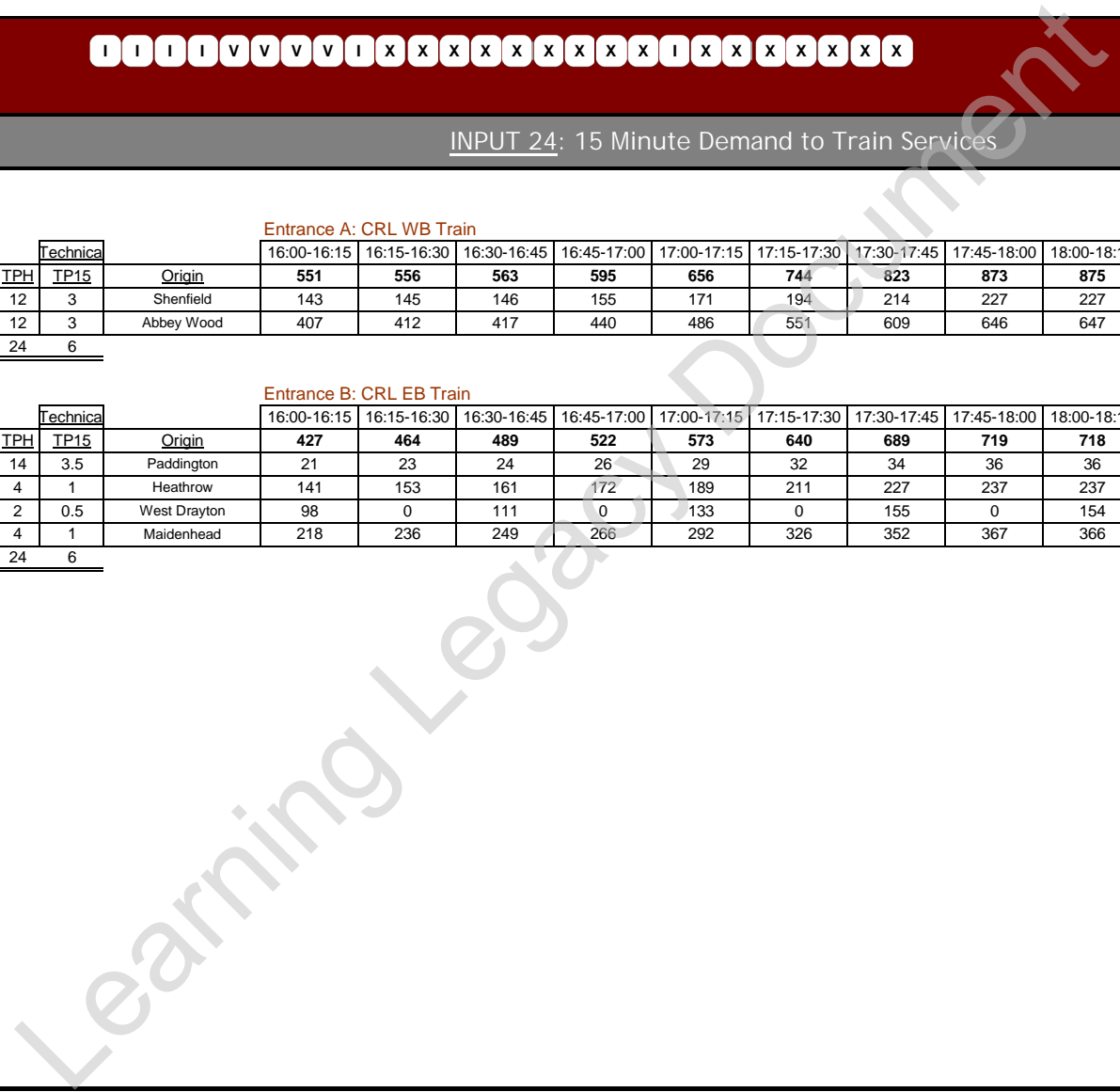
			Technica													
Popularity	TPH	TP15	Origin	16:00-16:15	16:15-16:30	16:30-16:45	16:45-17:00	17:00-17:15	17:15-17:30	17:30-17:45	17:45-18:00	18:00-18:15	18:15-18:30	18:30-18:45	18:45-19:00	
26%	12	3	Shenfield	551	556	563	595	656	744	823	873	875	847	794	724	8600
74%	12	3	Abbey Wood	407	412	417	440	486	551	609	646	647	627	587	535	
100%	24	6														

Entrance B: CRL EB Train

			Technica													
Popularity	TPH	TP15	Origin	16:00-16:15	16:15-16:30	16:30-16:45	16:45-17:00	17:00-17:15	17:15-17:30	17:30-17:45	17:45-18:00	18:00-18:15	18:15-18:30	18:30-18:45	18:45-19:00	
5%	14	3.5	Paddington	427	464	489	522	573	640	689	719	718	683	610	515	7050
33%	4	1	Heathrow	21	23	24	26	29	32	34	36	36	34	30	26	
11%	2	0.5	West Drayton	141	153	161	172	189	211	227	237	237	225	201	170	
51%	4	1	Maidenhead	98	0	111	0	133	0	155	0	154	0	124	0	
51%	4	1	Maidenhead	218	236	249	266	292	326	352	367	366	348	311	263	
100%	24	6														

8600

7050





INPUT 25: B & A Percentages

List of Input Assumptions	CRL	LU
1. CAD (Extent of Model)	Y	Y
2. TPH	Y	Y
3. Escalator Config.		
4. Gateline Config.		
5. Ticketing		
6. PRM Routings and Rules		
7. Non-PRM Routings		
8. One-Way System Elements		
9. CRL Adit Usage	Y	Y
10. CRL Timetable	Y	Y
11. CRL Cancelled Train Logic		
12. LU Timetable		
13. NR / Other Timetable		
14. Constraining Alighters Logic	Y	Y
15. Constraining Boarders Logic		
16. Boarding Profiles (CRL)	Y	Y
17. Boarding Profiles (LU / Other)		
18. Alighting Profiles (CRL)	Y	Y
19. Alighting Profiles (LU / Other)		
20. Boarding Logic	Y	Y
21. Dwell Time Logic	Y	Y
22. 15 Minute Profiling	Y	Y
23. TPH broken up into 15 minute periods	Y	Y
24. 15 Minute Demand to Train Services	Y	Y
25. B & A Percentages		
26. Accuracy of Seams		

Railplan Source:  (2026XR)

**CRL**  
Boarding Percentages

CRL WB Any (Destination is Paddington)	<input type="text" value="22.0%"/>
CRL WB Any Post PAD-WD (Destination is stations between Paddington and West Drayton)	<input type="text" value="62.0%"/>
CRL WB Heathrow (Destination is Heathrow Airport)	<input type="text" value="4.0%"/>
CRL WB Any Post WD-MAID (Destination is stations between West Drayton and Maidenhead)	<input type="text" value="12.0%"/>
	<hr/> <hr/> <input type="text" value="100%"/>

CRL EB Any (Destination is any station between TCR and Whitechapel)	<input type="text" value="20.0%"/>
CRL EB Shenfield (Destination is any station on the Shenfield Branch)	<input type="text" value="46.0%"/>
CRL EB Abbey Wood (Destination is any station on the Abbey Wood Branch)	<input type="text" value="34.0%"/>
	<hr/> <hr/> <input type="text" value="100%"/>

Alighting Percentages

Split of CRL WB Alighters originating from a Shenfield Service	<input type="text" value="26.0%"/>
Split of CRL WB Alighters originating from a Abbey Wood Service	<input type="text" value="74.0%"/>
	<hr/> <hr/> <input type="text" value="100%"/>
Split of CRL EB Alighters originating from a Paddington Service	<input type="text" value="5.0%"/>
Split of CRL EB Alighters originating from a Heathrow Service	<input type="text" value="33.0%"/>
Split of CRL EB Alighters originating from a West Drayton Service	<input type="text" value="11.0%"/>
Split of CRL EB Alighters originating from a Maidenhead Service	<input type="text" value="51.0%"/>
	<hr/> <hr/> <input type="text" value="100%"/>

Train Load Percentages (for assistance with logic around impact on Cancelled Train)

Percentage of a WB train load from Shenfield alighting at Whitechapel	<input type="text"/>
Percentage of a WB train load from Abbey Wood alighting at Whitechapel	<input type="text"/>
Percentage of a WB train load from Paddington alighting at Whitechapel	<input type="text"/>
Percentage of a WB train load from Heathrow alighting at Whitechapel	<input type="text"/>
Percentage of a WB train load from West Drayton alighting at Whitechapel	<input type="text"/>
Percentage of a WB train load from Maidenhead alighting at Whitechapel	<input type="text"/>

List of Input Assumptions

CRL LU

INPUT 26: Accuracy of Seams

The only seam outside of Crossrail in the Bond Street model is the demand from LUL services. LU have provided a demand profile of pedestrians going from LUL services to Bond Street Crossrail (from the Bond Street Upgrade Legion Model) and this has been adopted within the Legion model.

1. CAD (Extent of Model)	Y	Y
2. TPH	Y	Y
3. Escalator Config.		
4. Gateline Config.		
5. Ticketing		
6. PRM Routings and Rules		
7. Non-PRM Routings		
8. One-Way System Elements		
9. CRL Adit Usage	Y	Y
10. CRL Timetable	Y	Y
11. CRL Cancelled Train Logic		
12. LU Timetable		
13. NR / Other Timetable		
14. Constraining Alighters Logic	Y	Y
15. Constraining Boarders Logic		
16. Boarding Profiles (CRL)	Y	Y
17. Boarding Profiles (LU / Other)		
18. Alighting Profiles (CRL)	Y	Y
19. Alighting Profiles (LU / Other)		
20. Boarding Logic	Y	Y
21. Dwell Time Logic	Y	Y
22. 15 Minute Profiling	Y	Y
23. TPH broken up into 15 minute periods	Y	Y
24. 15 Minute Demand to Train Services	Y	Y
25. B & A Percentages		
26. Accuracy of Seams		

Learning Legacy Document

List of Input Assumptions

CRL LU

INPUT 27: PRM Types and Proportions

1. CAD (Extent of Model)

Y Y

2. TPH

Y Y

3. Escalator Config.

4. Gateline Config.

5. Ticketing

6. PRM Routings and Rules

7. Non-PRM Routings

8. One-Way System Elements

9. CRL Adit Usage

Y Y

10. CRL Timetable

Y Y

11. CRL Cancelled Train Logic

12. LU Timetable

13. NR / Other Timetable

14. Constraining Alighters Logic

Y Y

15. Constraining Boarders Logic

16. Boarding Profiles (CRL)

Y Y

17. Boarding Profiles (LU / Other)

18. Alighting Profiles (CRL)

Y Y

19. Alighting Profiles (LU / Other)

20. Boarding Logic

Y Y

21. Dwell Time Logic

Y Y

22. 15 Minute Profiling

Y Y

23. TPH broken up into 15 minute periods

Y Y

24. 15 Minute Demand to Train Services

Y Y

25. B & A Percentages

Y Y

26. Accuracy of Seams

27. PRM Types and Proportions

This is taken from the Multi-Disciplinary Consultant Works Package 2 Bond St Crossrail Station - Legion Modeeling Report  
Bond St - SD3 Legion Modelling Report (ARUP)  
Document Number: CR-SD-BOS-CE-RT-00011

Table 9: 2016 PRM Types and proportions

Physically impaired			Encumbered			
Wheelchair User	Disabled	Elderly Impaired	Adults with Young Children	Heavy Shopping Bags	Medium Luggage	Large Luggage Items
A	B	B	E	C	C	D
0.010%	0.529%	0.389%	0.348%	1.020%	1.000%	0.405%
0.928%			2.773%			
3.701%						

BOND STREET				
Crossrail WB Platform - AM Peak - 2026 - 24 TPH				
			<u>Origin</u>	<u>Destination</u>
CRL	07:01:09	07:01:54	ABW	HRW
CRL	07:03:30	07:04:15	SHN	PAD
CRL	07:06:17	07:07:02	ABW	PAD
CRL	07:08:30	07:09:15	SHN	PAD
CRL	07:10:59	07:11:44	ABW	MHD
CRL	07:13:28	07:14:13	SHN	PAD
CRL	07:16:13	07:16:58	ABW	HRW
CRL	07:19:06	07:19:51	SHN	PAD
CRL	07:21:36	07:22:21	ABW	PAD
CRL	07:23:32	07:24:17	SHN	MHD
CRL	07:25:56	07:26:41	ABW	WDR
CRL	07:28:43	07:29:28	SHN	PAD
CRL	07:31:14	07:31:59	ABW	HRW
CRL	07:33:52	07:34:37	SHN	PAD
CRL	07:36:24	07:37:09	ABW	PAD
CRL	07:38:53	07:39:38	SHN	PAD
CRL	07:41:14	07:41:59	ABW	MHD
CRL	07:44:11	07:44:56	SHN	PAD
CRL	07:46:41	07:47:26	ABW	HRW
CRL	07:49:13	07:49:58	SHN	PAD
CRL	07:51:25	07:52:10	ABW	PAD
CRL	07:53:51	07:54:36	SHN	MHD
CRL	07:56:47	07:57:32	ABW	WDR
CRL	07:58:32	07:59:17	SHN	PAD
CRL	08:00:59	08:01:44	ABW	HRW
CRL	08:03:27	08:04:12	SHN	PAD
CRL	08:05:56	08:06:41	ABW	PAD
CRL	08:08:27	08:09:12	SHN	PAD
CRL	08:11:28	08:12:13	ABW	MHD
CRL	08:13:27	08:14:12	SHN	PAD
CRL	08:16:07	08:16:52	ABW	HRW
CRL	08:18:27	08:19:12	SHN	PAD
CRL	08:20:59	08:21:44	ABW	PAD
CRL	08:24:01	08:24:46	SHN	MHD
CRL	08:26:09	08:26:54	ABW	WDR
CRL	08:29:08	08:29:53	SHN	PAD
CRL	08:30:59	08:31:44	ABW	HRW
CRL	08:33:24	08:34:09	SHN	PAD
CRL	08:36:11	08:36:56	ABW	PAD
CRL	08:39:03	08:39:48	SHN	PAD
CRL	08:41:27	08:42:12	ABW	MHD
CRL	08:43:57	08:44:42	SHN	PAD
CRL	08:45:57	08:46:42	ABW	HRW
CRL	08:48:36	08:49:21	SHN	PAD
CRL	08:51:48	08:52:33	ABW	PAD
CRL	08:53:38	08:54:23	SHN	MHD
CRL	08:56:06	08:56:51	ABW	WDR
CRL	08:58:41	08:59:26	SHN	PAD
CRL	09:01:17	09:02:02	ABW	HRW
CRL	09:03:59	09:04:44	SHN	PAD
CRL	09:06:04	09:06:49	ABW	PAD
CRL	09:08:32	09:09:17	SHN	PAD
CRL	09:11:13	09:11:58	ABW	MHD
CRL	09:13:36	09:14:21	SHN	PAD
CRL	09:16:33	09:17:18	ABW	HRW
CRL	09:19:18	09:20:03	SHN	PAD
CRL	09:21:00	09:21:45	ABW	PAD
CRL	09:23:32	09:24:17	SHN	MHD
CRL	09:26:40	09:27:25	ABW	WDR
CRL	09:28:51	09:29:36	SHN	PAD
CRL	09:31:30	09:32:15	ABW	HRW
CRL	09:33:39	09:34:24	SHN	PAD
CRL	09:36:10	09:36:55	ABW	PAD
CRL	09:38:26	09:39:11	SHN	PAD
CRL	09:41:02	09:41:47	ABW	MHD
CRL	09:43:55	09:44:40	SHN	PAD
CRL	09:46:37	09:47:22	ABW	HRW
CRL	09:48:25	09:49:10	SHN	PAD
CRL	09:51:09	09:51:54	ABW	PAD
CRL	09:53:24	09:54:09	SHN	MHD
CRL	09:55:55	09:56:40	ABW	WDR
CRL	09:58:34	09:59:19	SHN	PAD

Descriptive Stats	
Peak Period	AM Peak
Future Year	2026
Trains Per Hour	24

07:00 to 10:00	
\$B\$10:\$B\$81	10 81
CRL	72
	100.00%
	0.00%
<b>Total</b>	<b>72</b>

07:00 to 08:00	
\$B\$10:\$B\$33	10 33
CRL	24
	100.00%
	0.00%
<b>Total</b>	<b>24</b>

08:00 to 09:00	
\$B\$34:\$B\$57	34 57
CRL	24
	100.00%
	0.00%
<b>Total</b>	<b>24</b>

09:00 to 10:00	
\$B\$58:\$B\$81	58 81
CRL	24
	100.00%
	0.00%
<b>Total</b>	<b>24</b>

BOND STREET				
Crossrail WB Platform - PM Peak - 2026 - 24 TPH				
			<u>Origin</u>	<u>Destination</u>
CRL	16:01:09	16:01:54	ABW	PAD
CRL	16:03:30	16:04:15	SHN	MHD
CRL	16:06:17	16:07:02	ABW	WD
CRL	16:08:30	16:09:15	SHN	PAD
CRL	16:10:59	16:11:44	ABW	HRW
CRL	16:13:28	16:14:13	SHN	PAD
CRL	16:16:13	16:16:58	ABW	PAD
CRL	16:19:06	16:19:51	SHN	PAD
CRL	16:21:36	16:22:21	ABW	MHD
CRL	16:23:32	16:24:17	SHN	PAD
CRL	16:25:56	16:26:41	ABW	HRW
CRL	16:28:43	16:29:28	SHN	PAD
CRL	16:31:14	16:31:59	ABW	PAD
CRL	16:33:52	16:34:37	SHN	MHD
CRL	16:36:24	16:37:09	ABW	WD
CRL	16:38:53	16:39:38	SHN	PAD
CRL	16:41:14	16:41:59	ABW	HRW
CRL	16:44:11	16:44:56	SHN	PAD
CRL	16:46:41	16:47:26	ABW	PAD
CRL	16:49:13	16:49:58	SHN	PAD
CRL	16:51:25	16:52:10	ABW	MHD
CRL	16:53:51	16:54:36	SHN	PAD
CRL	16:56:47	16:57:32	ABW	HRW
CRL	16:58:32	16:59:17	SHN	PAD
CRL	17:00:59	17:01:44	ABW	PAD
CRL	17:03:27	17:04:12	SHN	MHD
CRL	17:05:56	17:06:41	ABW	WD
CRL	17:08:27	17:09:12	SHN	PAD
CRL	17:11:28	17:12:13	ABW	HRW
CRL	17:13:27	17:14:12	SHN	PAD
CRL	17:16:07	17:16:52	ABW	PAD
CRL	17:18:27	17:19:12	SHN	PAD
CRL	17:20:59	17:21:44	ABW	MHD
CRL	17:24:01	17:24:46	SHN	PAD
CRL	17:26:09	17:26:54	ABW	HRW
CRL	17:29:08	17:29:53	SHN	PAD
CRL	17:30:59	17:31:44	ABW	PAD
CRL	17:33:24	17:34:09	SHN	MHD
CRL	17:36:11	17:36:56	ABW	WD
CRL	17:39:03	17:39:48	SHN	PAD
CRL	17:41:27	17:42:12	ABW	HRW
CRL	17:43:57	17:44:42	SHN	PAD
CRL	17:45:57	17:46:42	ABW	PAD
CRL	17:48:36	17:49:21	SHN	PAD
CRL	17:51:48	17:52:33	ABW	MHD
CRL	17:53:38	17:54:23	SHN	PAD
CRL	17:56:06	17:56:51	ABW	HRW
CRL	17:58:41	17:59:26	SHN	PAD
CRL	18:01:17	18:02:02	ABW	PAD
CRL	18:03:59	18:04:44	SHN	MHD
CRL	18:06:04	18:06:49	ABW	WD
CRL	18:08:32	18:09:17	SHN	PAD
CRL	18:11:13	18:11:58	ABW	HRW
CRL	18:13:36	18:14:21	SHN	PAD
CRL	18:16:33	18:17:18	ABW	PAD
CRL	18:19:18	18:20:03	SHN	PAD
CRL	18:21:00	18:21:45	ABW	MHD
CRL	18:23:32	18:24:17	SHN	PAD
CRL	18:26:40	18:27:25	ABW	HRW
CRL	18:28:51	18:29:36	SHN	PAD
CRL	18:31:30	18:32:15	ABW	PAD
CRL	18:33:39	18:34:24	SHN	MHD
CRL	18:36:10	18:36:55	ABW	WD
CRL	18:38:26	18:39:11	SHN	PAD
CRL	18:41:02	18:41:47	ABW	HRW
CRL	18:43:55	18:44:40	SHN	PAD
CRL	18:46:37	18:47:22	ABW	PAD
CRL	18:48:25	18:49:10	SHN	PAD
CRL	18:51:09	18:51:54	ABW	MHD
CRL	18:53:24	18:54:09	SHN	PAD
CRL	18:55:55	18:56:40	ABW	HRW
CRL	18:58:34	18:59:19	SHN	PAD

Descriptive Stats	
Peak Period	PM Peak
Future Year	2026
Trains Per Hour	24

07:00 to 10:00	
\$B\$10:\$B\$81	10 81
CRL	72
	100.00%
	0.00%
<b>Total</b>	<b>72</b>

07:00 to 08:00	
\$B\$10:\$B\$33	10 33
CRL	24
	100.00%
	0.00%
<b>Total</b>	<b>24</b>

08:00 to 09:00	
\$B\$34:\$B\$57	34 57
CRL	24
	100.00%
	0.00%
<b>Total</b>	<b>24</b>

09:00 to 10:00	
\$B\$58:\$B\$81	58 81
CRL	24
	100.00%
	0.00%
<b>Total</b>	<b>24</b>

Learning Legal Document



RODS2008

	1600-1615	1615-1630	1630-1645	1645-1700	1700-1715	1715-1730	1730-1745	1745-1800	1800-1815	1815-1830	1830-1845	1845-1900	total
BOND STREET T H	1303	1373	1479	1660	1945	2185	2366	2410	2343	2172	1982	1790	23008
BOND STREET EXITS	0	0	0	0	0	0	0	0	0	0	0	0	0
BOND STREET CENTRAL WB	401	405	410	433	478	542	599	636	637	617	578	527	6263
BOND STREET CENTRAL EB	284	308	325	347	381	425	458	478	477	454	405	342	4684
BOND STREET JUBILEE NB	511	543	574	616	674	763	846	907	908	850	742	618	8552
BOND STREET JUBILEE SB	229	249	265	273	287	310	325	330	319	291	247	199	3324

BOND STREET TH	5.66%	5.97%	6.43%	7.21%	8.45%	9.50%	10.28%	10.47%	10.18%	9.44%	8.61%	7.78%
BOND STREET CENTRAL WB	6.40%	6.47%	6.55%	6.91%	7.63%	8.65%	9.56%	10.15%	10.17%	9.85%	9.23%	8.41%
BOND STREET CENTRAL EB	6.06%	6.58%	6.94%	7.41%	8.13%	9.07%	9.78%	10.20%	10.18%	9.69%	8.65%	7.30%
BOND STREET JUBILEE NB	5.98%	6.35%	6.71%	7.20%	7.88%	8.92%	9.89%	10.61%	10.62%	9.94%	8.68%	7.23%
BOND STREET JUBILEE SB	6.89%	7.49%	7.97%	8.21%	8.63%	9.33%	9.78%	9.93%	9.60%	8.75%	7.43%	5.99%

Proxy Required.....

CRL WB	6.40%	6.47%	6.55%	6.91%	7.63%	8.65%	9.56%	10.15%	10.17%	9.85%	9.23%	8.41%
CRL EB	6.06%	6.58%	6.94%	7.41%	8.13%	9.07%	9.78%	10.20%	10.18%	9.69%	8.65%	7.30%

Learning Legacy Document



**Appendix C – AM Peak 2026+28% Cover Sheet**

Learning Legacy Document

<u>List of Input Assumptions</u>	<u>CRL</u>	<u>LU</u>
1. CAD (Extent of Model)	Y	Y
2. TPH	Y	Y
3. Escalator Config.		
4. Gateline Config.		
5. Ticketing		
6. PRM Routings and Rules		
7. Non-PRM Routings		
8. One-Way System Elements		
9. CRL Adit Usage	Y	Y
10. CRL Timetable	Y	Y
11. CRL Cancelled Train Logic		
12. LU Timetable		
13. NR / Other Timetable		
14. Constraining Alighters Logic	Y	Y
15. Constraining Boarders Logic		
16. Boarding Profiles (CRL)	Y	Y
17. Boarding Profiles (LU / Other)		
18. Alighting Profiles (CRL)	Y	Y
19. Alighting Profiles (LU / Other)		
20. Boarding Logic	Y	Y
21. Dwell Time Logic	Y	Y
22. 15 Minute Profiling	Y	Y
23. TPH broken up into 15 minute periods	Y	Y
24. 15 Minute Demand to Train Services	Y	Y
25. B & A Percentages		
26. Accuracy of Seams		



## Version Control for 'ACS Bond Street CRL Complex (2026 plus 28% AM)'

Version Number	Date	Comments/Changes	Submitted by	Model Builder File Name (if applicable)
v1.0	09/07/2010	<b>Sent from Robert Duff (LU) to Nick Gavrielides (CRL) to be passed on to each respective Framework Consultant.</b> Assumption 4: Ticketing is still outstanding (FDC's informed to proceed with whatever's in their current model), Assumption 11: Cancelled Train Logic is to be determined when the perfect timetable set-up spreadsheets are sent back to CRL by the FDC, Assumption 15: In line with the Cancelled Train timetable amendments due to be undertaken by CRL. The Train Load Percentages in Assumption 25 will need to be filled in once the correct cancelled train has been determined. Assumption 25: CRL Modelling Team to inform B&A %'s from Railplan Run	Robert Duff (LU)	N/A
v2	06/10/2010	Sent from C132 to Crossrail pedestrian modelling team	Christine Palmer (WSP)	Bond St AM 2026+28% Sept 2010 For Report.lgm
v3	22/11/2010	A meeting between LUL, C132 and Crossrail on 10th November 2010 was held to discuss the issues highlighted in the model audit. Following this meeting a list of actions was completed by LUL for C132 to incorporate into the models.	Christine Palmer (WSP)	Bond St AM 2026+28% Nov 2010 For Report.lgm
v4	26/07/2011	Following the November Audit the following changes have been made to the Cover sheet: CAD Updated to Stage E CAD for Davies Street and Intermediate Level ( <b>see sheet 1</b> ) Increased number of ticket gates at Davies Street and Hanover Square ( <b>see sheet 4</b> ) Non PRM's now can use WAG's at Hanover Square ( <b>see sheet 6</b> ) Eastbound train stopping position moved westwards and revised boarding profiles issued by Crossrail on 18/04/11 used ( <b>see sheet 16</b> ) Revised Bond Street PM Peak demand added into the <b>BDS 2026 Demand worksheet</b>	Christine Palmer (WSP)	Bond St AM 2026+28%_Issued July 2011.LGM
v5	19/08/2011	Finalised for Issue with Final Report - updated train position diagram added to sheet 3. Revised reference to CPFR on sheet 2 from CPFR 4 to 5.	Christine Palmer (WSP)	Bond St AM 2026+28%_Issued August 2011.LGM



List of Input Assumptions

CRL LU

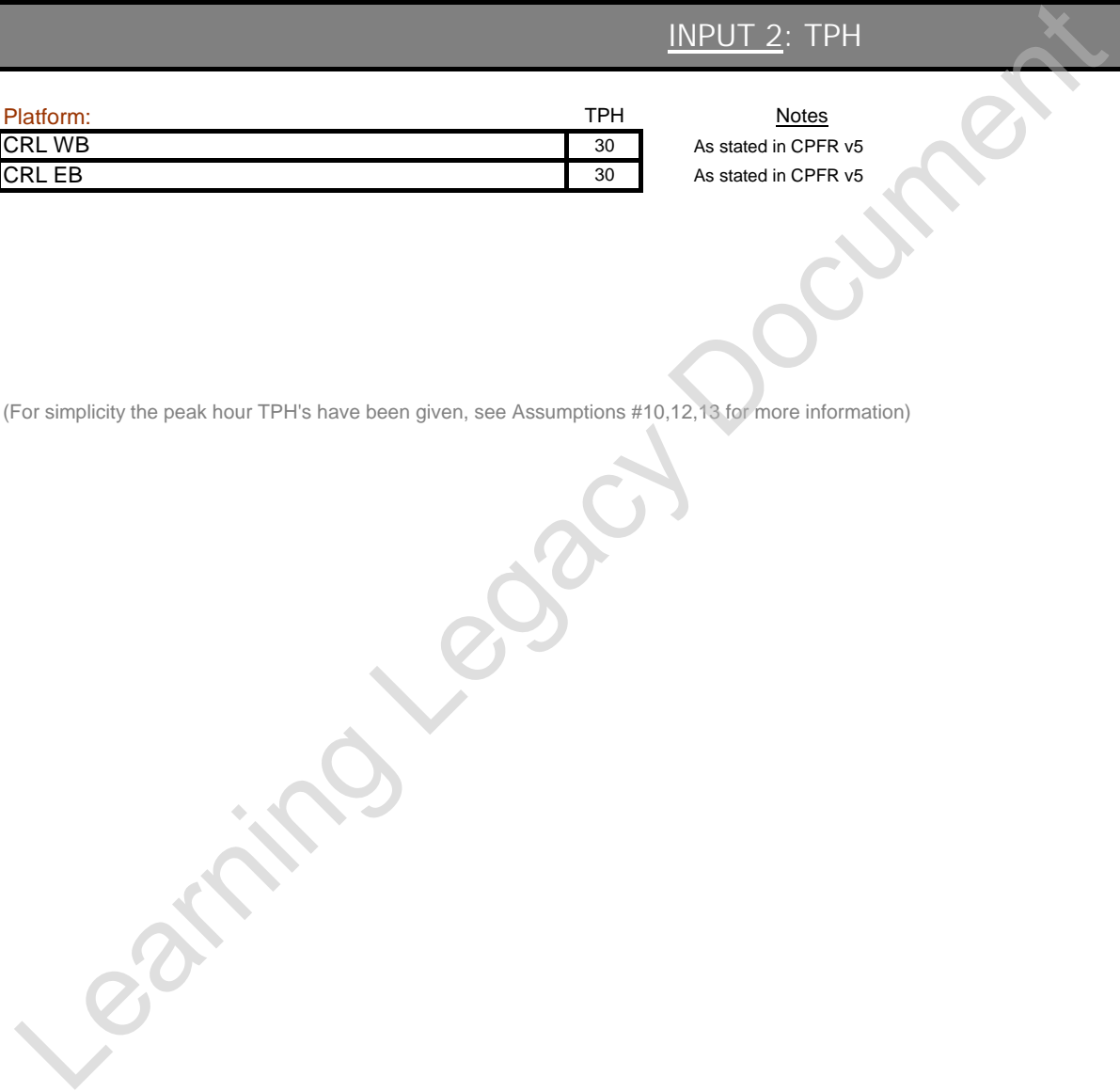
INPUT 2: TPH

- 1. CAD (Extent of Model) Y Y
- 2. TPH Y Y
- 3. Escalator Config. Y
- 4. Gateline Config. Y
- 5. Ticketing Y
- 6. PRM Routings and Rules Y
- 7. Non-PRM Routings Y
- 8. One-Way System Elements Y
- 9. CRL Adit Usage Y Y
- 10. CRL Timetable Y Y
- 11. CRL Cancelled Train Logic Y
- 12. LU Timetable Y
- 13. NR / Other Timetable Y
- 14. Constraining Alighters Logic Y Y
- 15. Constraining Boarders Logic Y
- 16. Boarding Profiles (CRL) Y Y
- 17. Boarding Profiles (LU / Other) Y
- 18. Alighting Profiles (CRL) Y Y
- 19. Alighting Profiles (LU / Other) Y
- 20. Boarding Logic Y Y
- 21. Dwell Time Logic Y Y
- 22. 15 Minute Profiling Y Y
- 23. TPH broken up into 15 minute periods Y Y
- 24. 15 Minute Demand to Train Services Y Y
- 25. B & A Percentages Y
- 26. Accuracy of Seams Y

Platform:	TPH
CRL WB	30
CRL EB	30

Notes  
As stated in CPFR v5  
As stated in CPFR v5

(For simplicity the peak hour TPH's have been given, see Assumptions #10,12,13 for more information)





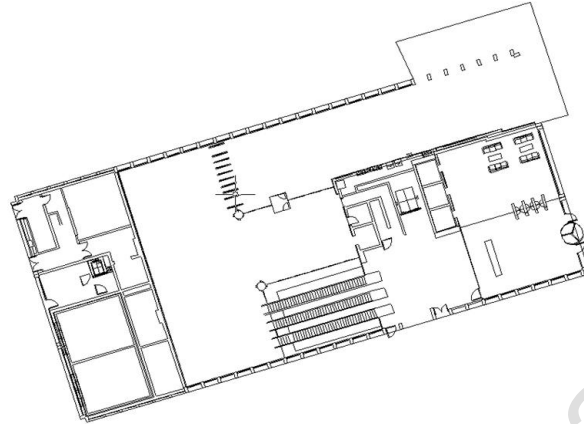
List of Input Assumptions

CRL LU

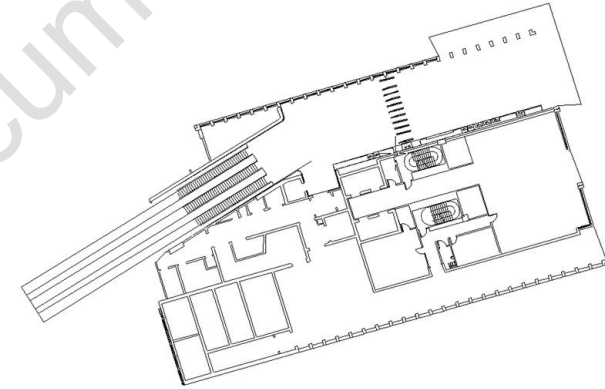
1. CAD (Extent of Model)	Y	Y
2. TPH	Y	Y
3. Escalator Config.		
4. Gateline Config.		
5. Ticketing		
6. PRM Routings and Rules		
7. Non-PRM Routings		
8. One-Way System Elements		
9. CRL Adit Usage	Y	Y
10. CRL Timetable	Y	Y
11. CRL Cancelled Train Logic		
12. LU Timetable		
13. NR / Other Timetable		
14. Constraining Alighters Logic	Y	Y
15. Constraining Boarders Logic		
16. Boarding Profiles (CRL)	Y	Y
17. Boarding Profiles (LU / Other)		
18. Alighting Profiles (CRL)	Y	Y
19. Alighting Profiles (LU / Other)		
20. Boarding Logic	Y	Y
21. Dwell Time Logic	Y	Y
22. 15 Minute Profiling	Y	Y
23. TPH broken up into 15 minute periods	Y	Y
24. 15 Minute Demand to Train Services	Y	Y
25. B & A Percentages		
26. Accuracy of Seams		

INPUT 4: Gateline Configurations

Davies Street CRL Ticket Hall



Hanover Square CRL Ticket Hall



No. Inwards UTS Gates	1
No. Outwards UTS Gate:	6
	<hr/>
	7
	<hr/>
No. Inwards WAGS	1
No. Outwards WAGS	1
No. Bi-Directional WAGS	0
	<hr/>
	2
	<hr/>

No. Inwards UTS Gates	1
No. Outwards UTS Gate:	7
	<hr/>
	8
	<hr/>
No. Inwards WAGS	1
No. Outwards WAGS	1
No. Bi-Directional WAGS	0
	<hr/>
	2
	<hr/>

Ticket capacity 33 pax/,min or 1.8 sec delay (taken from LUL Station Modelling with LEGION Best Practice Guide)

Ticket capacity 25 pax/,min or 2.4 sec delay - as per text below

(\*) There is the requirement that on any single gateline there should be two uni-directional WAGS positioned at either side of the gateline  
Bi-Directional WAGS are not favourable since they provide a throughput of just 7 pax/min compared to 25 pax/min of their uni-directional counterparts.

(\*\*) For any new ticket hall, the adequacy of the number of gates (proposed or current) should be backed up using the SPSG Gateline Formula.

List of Input Assumptions

CRL LU

INPUT 5: Ticketing

- 1. CAD (Extent of Model) Y Y
- 2. TPH Y Y
- 3. Escalator Config. Y Y
- 4. Gateline Config. Y Y
- 5. Ticketing Y Y
- 6. PRM Routings and Rules Y Y
- 7. Non-PRM Routings Y Y
- 8. One-Way System Elements Y Y
- 9. CRL Adit Usage Y Y
- 10. CRL Timetable Y Y
- 11. CRL Cancelled Train Logic Y Y
- 12. LU Timetable Y Y
- 13. NR / Other Timetable Y Y
- 14. Constraining Alighters Logic Y Y
- 15. Constraining Boarders Logic Y Y
- 16. Boarding Profiles (CRL) Y Y
- 17. Boarding Profiles (LU / Other) Y Y
- 18. Alighting Profiles (CRL) Y Y
- 19. Alighting Profiles (LU / Other) Y Y
- 20. Boarding Logic Y Y
- 21. Dwell Time Logic Y Y
- 22. 15 Minute Profiling Y Y
- 23. TPH broken up into 15 minute periods Y Y
- 24. 15 Minute Demand to Train Services Y Y
- 25. B & A Percentages Y Y
- 26. Accuracy of Seams Y Y

Davies Street CRL Ticket Hall:

Number of CRL TVM POM's 3 Transaction Time assumed: 20, 45, 75  
 Number of CRL TOP POM's 2 Transaction Time assumed: 10, 15, 30  
 % of accessing CRL/LU passengers that are assumed to require CRL POM's 6%

Hanover Square CRL Ticket Hall:

Number of CRL TVM POM's 3 Transaction Time assumed: 20, 45, 75  
 Number of CRL TOP POM's 2 Transaction Time assumed: 10, 15, 30  
 % of accessing CRL/LU passengers that are assumed to require CRL POM's 6%

LU LBPG

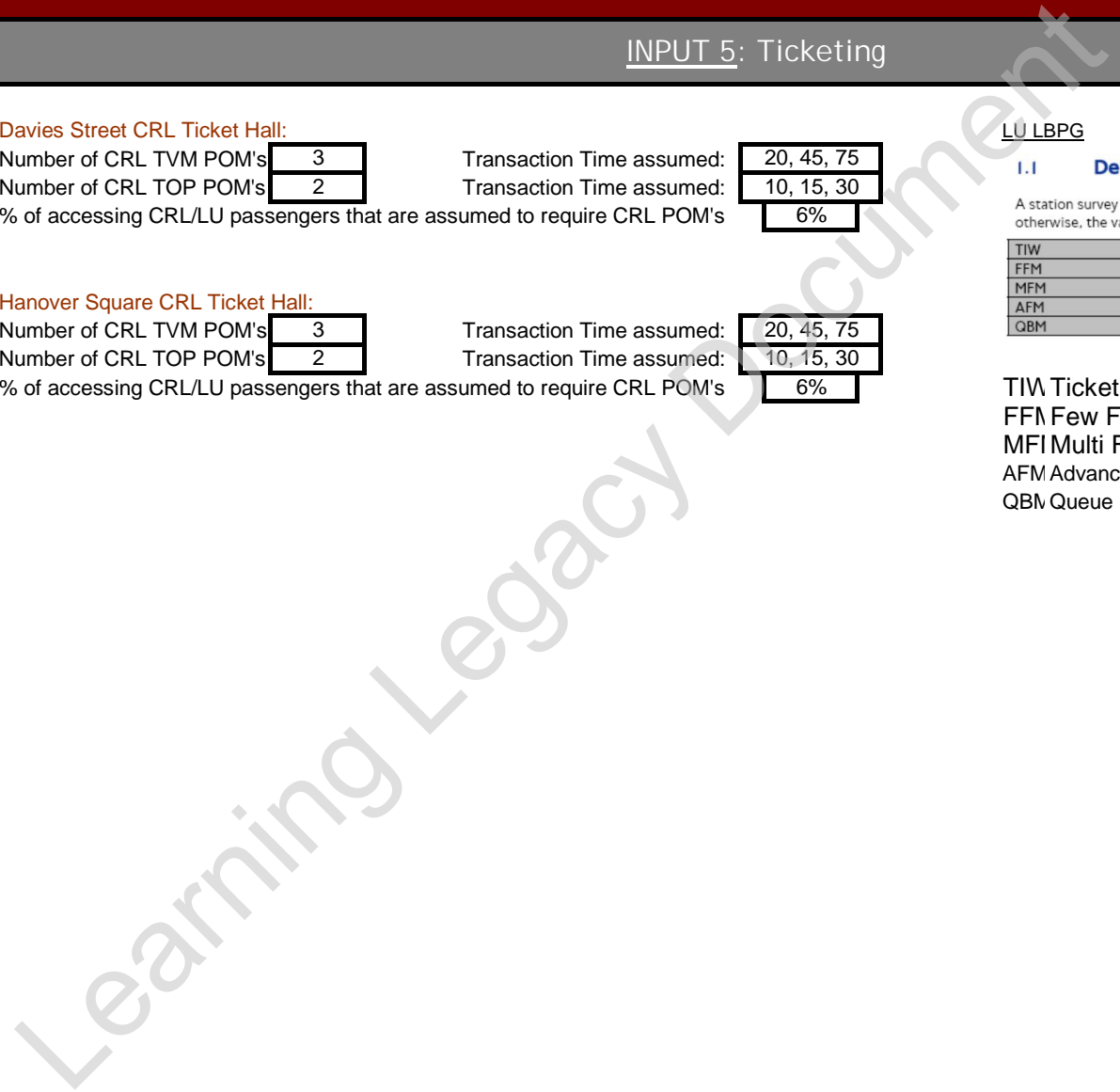
I.1 Delay used on ticket issuing facilities

A station survey should be conducted to collect the relevant information; otherwise, the values below may be used. All figures in seconds.

TIW	Variable: 20 (min), 40 (mean), 90 (max)
FFM	10, 15, 30
MFM	20, 45, 70
AFM	15, 20, 30
QBM	15, 40, 70

Source: LU LBPG (July 2009, Vol 3, Pg 1)

- TIW Ticket Issuing Window
- FFM Few Far Machine
- MFI Multi Fare Machine
- AFM Advanced Fare Machine
- QBM Queue Buster Machine



List of Input Assumptions		CRL	LU
1. CAD (Extent of Model)		Y	Y
2. TPH		Y	Y
3. Escalator Config.			
4. Gateline Config.			
5. Ticketing			
6. PRM Routings and Rules			
7. Non-PRM Routings			
8. One-Way System Elements			
9. CRL Adit Usage		Y	Y
10. CRL Timetable		Y	Y
11. CRL Cancelled Train Logic			
12. LU Timetable			
13. NR / Other Timetable			
14. Constraining Alighters Logic		Y	Y
15. Constraining Boarders Logic		Y	Y
16. Boarding Profiles (CRL)		Y	Y
17. Boarding Profiles (LU / Other)			
18. Alighting Profiles (CRL)		Y	Y
19. Alighting Profiles (LU / Other)			
20. Boarding Logic		Y	Y
21. Dwell Time Logic		Y	Y
22. 15 Minute Profiling		Y	Y
23. TPH broken up into 15 minute periods		Y	Y
24. 15 Minute Demand to Train Services		Y	Y
25. B & A Percentages			
26. Accuracy of Seams			

INPUT 6: PRM Routings and Rules

**WAG Rules:**  
 The following PRM's get sent through the WAG:

PRM_A	Y
PRM_B	Y
PRM_C	N
PRM_D	Y
PRM_E	Y
Non PRMs (Hanover Square ONLY)	Y

**Lift Rules:**  
 The following PRM's get sent to the Lift:

PRM_A	Y
PRM_B	Y
PRM_C	N
PRM_D	Y
PRM_E	Y

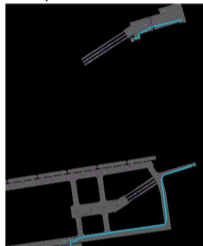
**Speeds and Sizes:**

Type	Diameter	Speed	
PRM_A	Large	0.58m/s	[Fixed]
PRM_B	Small	0.89m/s	[Fixed]
PRM_C	Medium	1.53m/s	[Normal Distribution]
PRM_D	Large	1.32m/s	[Normal Distribution]
PRM_E	Large	1.37m/s	[Normal Distribution]

Davies Street to Crossrail Westbound



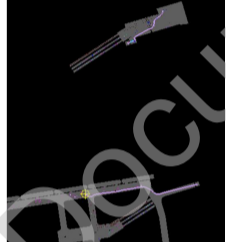
Hanover Square to Crossrail Westbound



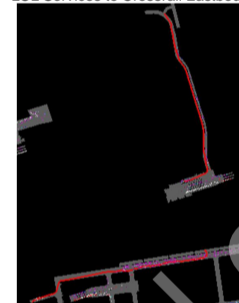
Davies Street to Crossrail Eastbound



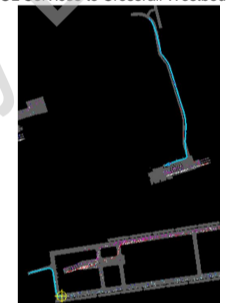
Hanover Square to Crossrail Eastbound



LUL Services to Crossrail Eastbound



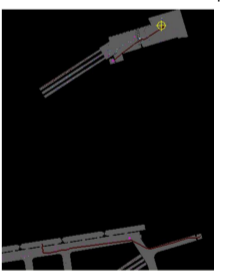
LUL Services to Crossrail Westbound



Crossrail Eastbound - Davies Street



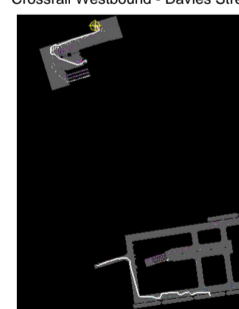
Crossrail Eastbound - Hanover Square



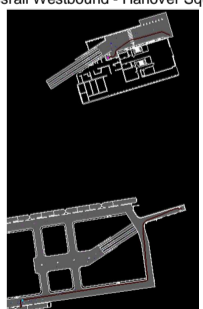
Crossrail Eastbound - LUL Services



Crossrail Westbound - Davies Street



Crossrail Westbound - Hanover Square



Crossrail Westbound - LUL Services



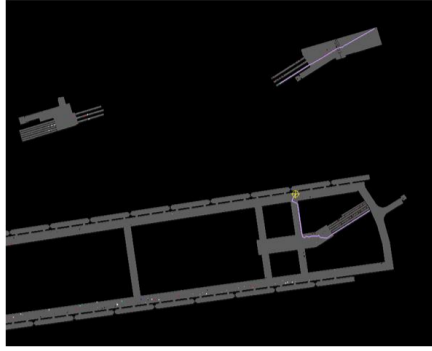
Learning Legacy Document

List of Input Assumptions

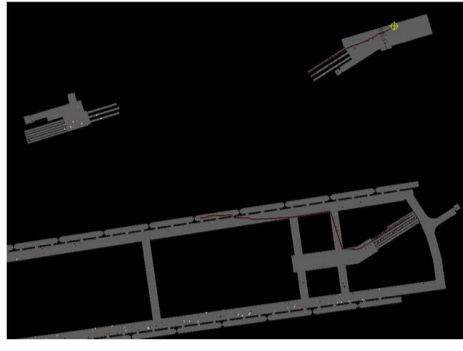
	CRL	LU
1. CAD (Extent of Model)	Y	Y
2. TPH	Y	Y
3. Escalator Config.		
4. GateLine Config.		
5. Ticketing		
6. PRM Routings and Rules		
7. Non-PRM Routings		
8. One-Way System Elements		
9. CRL Adit Usage	Y	Y
10. CRL Timetable	Y	Y
11. CRL Cancelled Train Logic		
12. LU Timetable		
13. NR / Other Timetable		
14. Constraining Alighters Logic	Y	Y
15. Constraining Boarders Logic		
16. Boarding Profiles (CRL)	Y	Y
17. Boarding Profiles (LU / Other)		
18. Alighting Profiles (CRL)	Y	Y
19. Alighting Profiles (LU / Other)		
20. Boarding Logic	Y	Y
21. Dwell Time Logic	Y	Y
22. 15 Minute Profiling	Y	Y
23. TPH broken up into 15 minute periods	Y	Y
24. 15 Minute Demand to Train Services	Y	Y
25. B & A Percentages		
26. Accuracy of Seams		

INPUT 7: Non-PRM Routings

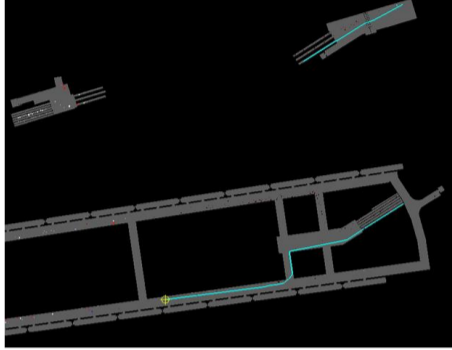
HS -> CRL EB:



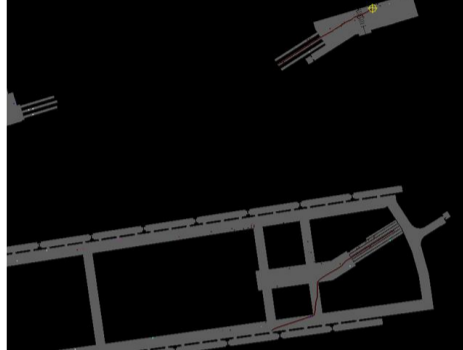
CRL EB -> HS:



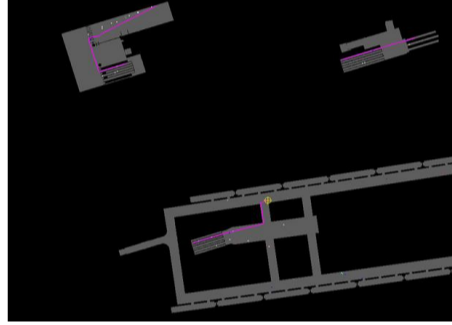
HS -> CRL WB:



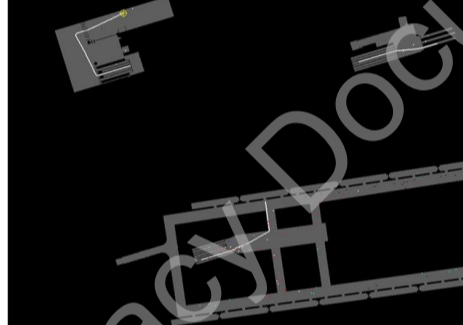
CRL WB -> HS:



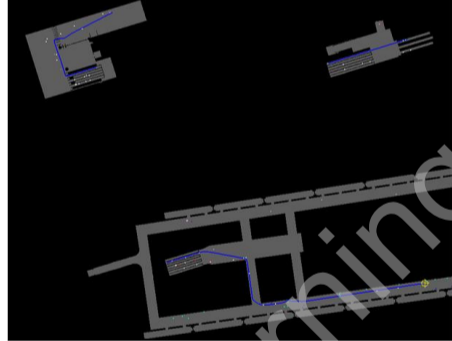
DS -> CRL EB:



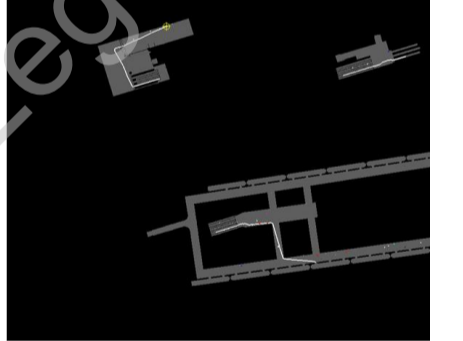
CRL EB -> DS:



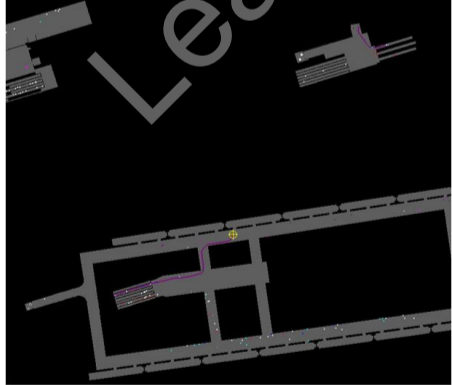
DS -> CRL WB:



CRL WB -> DS:



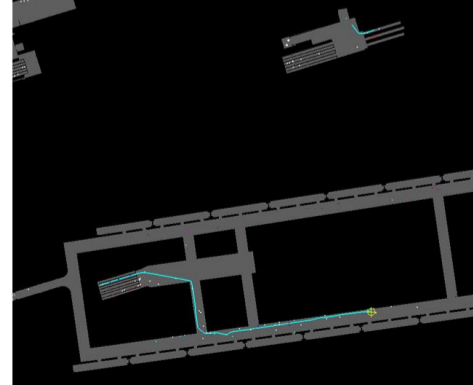
LUL -> CRL EB:



CRL EB -> LUL:



LUL -> CRL WB:



CRL WB -> LUL:





List of Input Assumptions

CRL LU

INPUT 8: One-Way System Elements

1. CAD (Extent of Model)	Y	Y
2. TPH	Y	Y
3. Escalator Config.		
4. Gateline Config.		
5. Ticketing		
6. PRM Routings and Rules		
7. Non-PRM Routings		
8. One-Way System Elements		
9. CRL Adit Usage	Y	Y
10. CRL Timetable	Y	Y
11. CRL Cancelled Train Logic		
12. LU Timetable		
13. NR / Other Timetable		
14. Constraining Alighters Logic	Y	Y
15. Constraining Boarders Logic		
16. Boarding Profiles (CRL)	Y	Y
17. Boarding Profiles (LU / Other)		
18. Alighting Profiles (CRL)	Y	Y
19. Alighting Profiles (LU / Other)		
20. Boarding Logic	Y	Y
21. Dwell Time Logic	Y	Y
22. 15 Minute Profiling	Y	Y
23. TPH broken up into 15 minute periods	Y	Y
24. 15 Minute Demand to Train Services	Y	Y
25. B & A Percentages		
26. Accuracy of Seams		

No One-Way passageways / staircases in Bond Street CRL Model

Learning Legacy Document

List of Input Assumptions

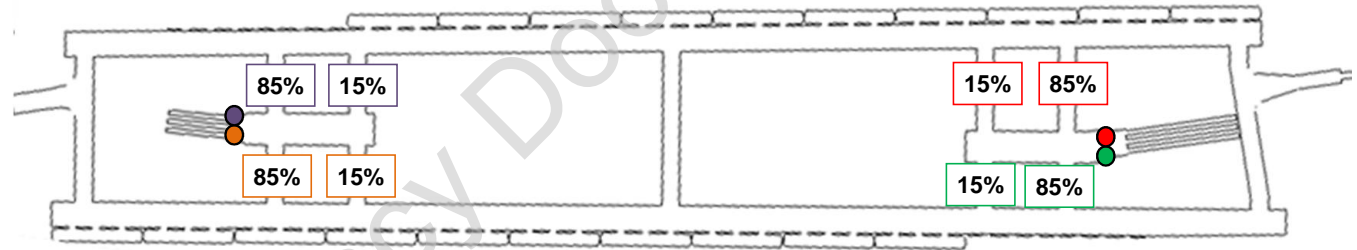
CRL LU

1. CAD (Extent of Model)	Y	Y
2. TPH	Y	Y
3. Escalator Config.		
4. Gateline Config.		
5. Ticketing		
6. PRM Routings and Rules		
7. Non-PRM Routings		
8. One-Way System Elements		
9. CRL Adit Usage	Y	Y
10. CRL Timetable	Y	Y
11. CRL Cancelled Train Logic		
12. LU Timetable		
13. NR / Other Timetable		
14. Constraining Alighters Logic	Y	Y
15. Constraining Boarders Logic		
16. Boarding Profiles (CRL)	Y	Y
17. Boarding Profiles (LU / Other)		
18. Alighting Profiles (CRL)	Y	Y
19. Alighting Profiles (LU / Other)		
20. Boarding Logic	Y	Y
21. Dwell Time Logic	Y	Y
22. 15 Minute Profiling	Y	Y
23. TPH broken up into 15 minute periods	If	Y
24. 15 Minute Demand to Train Services	Y	Y
25. B & A Percentages		
26. Accuracy of Seams		

INPUT 9: CRL Adit Usage

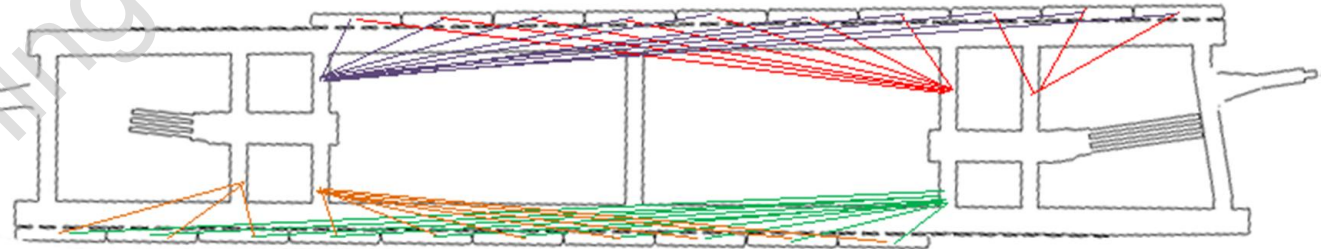
Boarders:

Strict % split assumption as detailed in below diagram.  
Specific Rules will exist for certain types of PRM's (see Assumption #6 for more information)



Alighters:

Logic Rule: Passengers as soon as they step off the train aim for the lower escalator concourse on the western/eastern end of the platforms and apply 'Shortest Distance' logic to determine the adit to be used. If this leads to unrealistic crowding in one adit while leaving the next adit along under-utilised, a reassignment to the less utilised adit would be appropriate.  
Certain Rules will exist for certain types of PRM's (see Assumption #6 for more information).



NB. Train Stopping positions (10 cars) may not necessarily be as depicted in the indicative diagrams above. The chief purpose of the diagrams are to illustratively highlight the logic to be applied in these areas.

List of Input Assumptions

CRL LU

1. CAD (Extent of Model)	Y	Y
2. TPH	Y	Y
3. Escalator Config.		
4. Gateline Config.		
5. Ticketing		
6. PRM Routings and Rules		
7. Non-PRM Routings		
8. One-Way System Elements		
9. CRL Adit Usage	Y	Y
10. CRL Timetable	Y	Y
11. CRL Cancelled Train Logic		
12. LU Timetable		
13. NR / Other Timetable		
14. Constraining Alighters Logic	Y	Y
15. Constraining Boarders Logic		
16. Boarding Profiles (CRL)	Y	Y
17. Boarding Profiles (LU / Other)		
18. Alighting Profiles (CRL)	Y	Y
19. Alighting Profiles (LU / Other)		
20. Boarding Logic	Y	Y
21. Dwell Time Logic	Y	Y
22. 15 Minute Profiling	Y	Y
23. TPH broken up into 15 minute periods	Y	Y
24. 15 Minute Demand to Train Services	Y	Y
25. B & A Percentages		
26. Accuracy of Seams		

INPUT 10: CRL Timetable

**CRL WB Platform - Descriptive Summary**

Origin	TPH 7-8	TPH 8-9	TPH 9-10	Total 7-10
Shenfield	18	18	18	54
Abbey Wood	12	12	12	36
	30	30	30	90

Destination	TPH 7-8	TPH 8-9	TPH 9-10	Total 7-10
Paddington	14	14	14	42
Heathrow	4	4	4	12
West Drayton	4	4	4	12
Ealing Broadway	4	4	4	12
Maidenhead	4	4	4	12
	30	30	30	90

**CRL EB Platform - Descriptive Summary**

Origin	TPH 7-8	TPH 8-9	TPH 9-10	Total 7-10
Paddington	14	14	14	42
Heathrow	4	4	4	12
West Drayton	4	4	4	12
Ealing Broadway	4	4	4	12
Maidenhead	4	4	4	12
	30	30	30	90

Destination	TPH 7-8	TPH 8-9	TPH 9-10	Total 7-10
Shenfield	18	18	18	54
Abbey Wood	12	12	12	36
	30	30	30	90

List of Input Assumptions

CRL LU

- 1. CAD (Extent of Model) Y Y
- 2. TPH Y Y
- 3. Escalator Config. Y
- 4. Gateline Config. Y
- 5. Ticketing Y
- 6. PRM Routings and Rules Y
- 7. Non-PRM Routings Y
- 8. One-Way System Elements Y
- 9. CRL Adit Usage Y Y
- 10. CRL Timetable Y Y
- 11. CRL Cancelled Train Logic Y Y
- 12. LU Timetable Y
- 13. NR / Other Timetable Y
- 14. Constraining Alighters Logic Y Y
- 15. Constraining Boarders Logic Y Y
- 16. Boarding Profiles (CRL) Y Y
- 17. Boarding Profiles (LU / Other) Y Y
- 18. Alighting Profiles (CRL) Y Y
- 19. Alighting Profiles (LU / Other) Y Y
- 20. Boarding Logic Y Y
- 21. Dwell Time Logic Y Y
- 22. 15 Minute Profiling Y Y
- 23. TPH broken up into 15 minute periods Y Y
- 24. 15 Minute Demand to Train Services Y Y
- 25. B & A Percentages Y Y
- 26. Accuracy of Seams Y Y

INPUT 11: CRL Cancelled Train Logic

**CRL WB Platform - Descriptive Summary**

Origin	TPH 7-8	TPH 8-9	TPH 9-10	Total 7-10
Shenfield	18	17	18	53
Abbey Wood	12	12	12	36
	30	29	30	89

Destination	TPH 7-8	TPH 8-9	TPH 9-10	Total 7-10
Paddington	14	14	14	42
Heathrow	4	3	4	11
West Drayton	4	4	4	12
Ealing Broadway	4	4	4	12
Maidenhead	4	4	4	12
	30	29	30	89

**CRL EB Platform - Descriptive Summary**

Origin	TPH 7-8	TPH 8-9	TPH 9-10	Total 7-10
Paddington	14	14	14	42
Heathrow	4	4	4	12
West Drayton	4	4	4	12
Ealing Broadway	4	4	4	12
Maidenhead	4	4	4	12
	30	30	30	90

Destination	TPH 7-8	TPH 8-9	TPH 9-10	Total 7-10
Shenfield	18	18	18	54
Abbey Wood	12	12	12	36
	30	30	30	90

Cancellation Logic:

During the peak 15 minutes one train will be cancelled on one Crossrail platform. The train will be cancelled on the platform with the highest volume of passengers. If there are more alighters than boarders (usually the case in the AM peak) then the train with the most alighters will be cancelled, and similarly if there are more boarders than alighters (usually the case in the PM peak) then the train with the most popular destination will be cancelled.

In the cancelled train scenario, there will be more passengers than normal waiting on the platform and therefore more passengers trying to board the next train. In some cases it might therefore not be possible for all passengers to board the train following the cancelled train. The capacity will be assessed and boarders will be constrained so that capacity is not breached.

In the cancelled train scenario, there will also be more passengers alighting from subsequent trains. Generally the alighters that would have been on the cancelled train will be transferred onto the following trains travelling on the same route. For example, at Whitechapel if a westbound train from Shenfield is cancelled, the alighters that would have been on the cancelled train will be assumed to arrive on the following train from Shenfield. None of these passengers would arrive on trains from Abbey Wood as the line splits at Whitechapel. However, at stations further west, for example Bond Street, in the same situation the alighters from the cancelled train would arrive on the two following trains, some on the next train from Abbey Wood and some on the next train from Shenfield. This is because the passengers getting on between Whitechapel and Bond Street could come on the next train following the cancelled train, which would be from Abbey Wood, but passengers getting on east of Whitechapel would have to board the next train from Shenfield. The split between the two trains will be based on the general split from Shenfield and Abbey Wood.

In some cases, this approach would cause the number of alighters on the trains following the cancelled train to exceed capacity. This will be assessed and the number of alighters per train will be limited so as not to exceed the total capacity. For example, at Whitechapel if the cancelled train from Shenfield would have had 300 alighters, the initial calculation would put 600 alighters on the following train from Shenfield. However, if the percentage of the train load alighting at Whitechapel is 30% then the maximum possible number of alighters would be 30% of 1700 (max train load) = 510. Therefore, the train from Shenfield following the cancelled train would be limited to 510 alighters as opposed to 600. The excess of 90 would be transferred to the following train from Shenfield, i.e. two trains (from Shenfield) after the cancelled train.

Where station designs on the platform area are not symmetrical it will be necessary to cancel a train on the least popular platform to ensure designs have been sufficiently tested.

List of Input Assumptions

	CRL	LU
1. CAD (Extent of Model)	Y	Y
2. TPH	Y	Y
3. Escalator Config.		
4. Gateline Config.		
5. Ticketing		
6. PRM Routings and Rules		
7. Non-PRM Routings		
8. One-Way System Elements		
9. CRL Adit Usage	Y	Y
10. CRL Timetable	Y	Y
11. CRL Cancelled Train Logic		
12. LU Timetable		
13. NR / Other Timetable		
14. Constraining Alighters Logic	Y	Y
15. Constraining Boarders Logic		
16. Boarding Profiles (CRL)	Y	Y
17. Boarding Profiles (LU / Other)		
18. Alighting Profiles (CRL)	Y	Y
19. Alighting Profiles (LU / Other)		
20. Boarding Logic	Y	Y
21. Dwell Time Logic	Y	Y
22. 15 Minute Profiling	Y	Y
23. TPH broken up into 15 minute periods	Y	Y
24. 15 Minute Demand to Train Services	Y	Y
25. B & A Percentages		
26. Accuracy of Seams		

INPUT 12: LU Timetable

Not relevant for the Bond Street Crossrail Model.

Learning Legacy Document

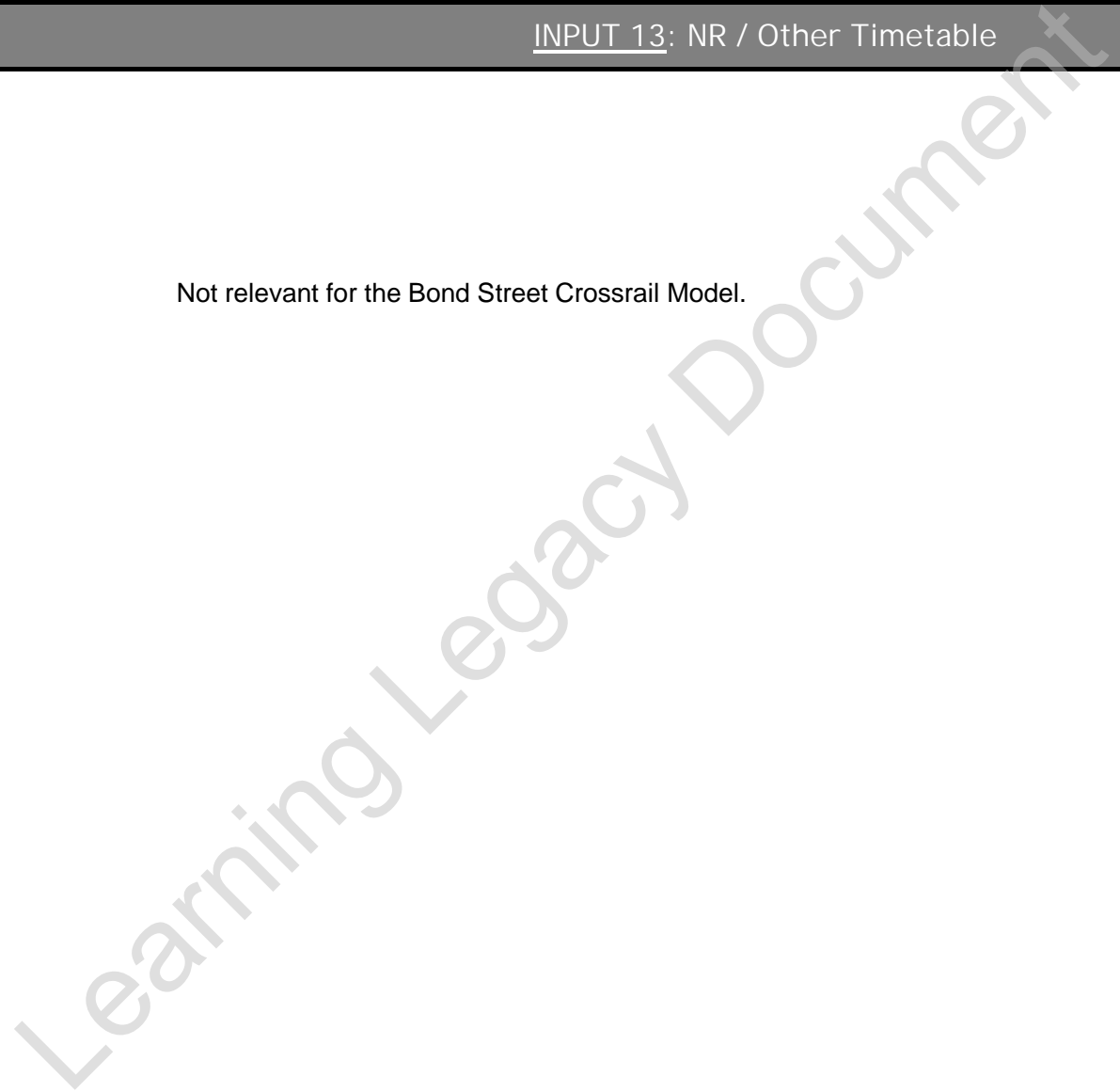
List of Input Assumptions

CRL LU

INPUT 13: NR / Other Timetable

1. CAD (Extent of Model)	Y	Y
2. TPH	Y	Y
3. Escalator Config.		
4. Gateline Config.		
5. Ticketing		
6. PRM Routings and Rules		
7. Non-PRM Routings		
8. One-Way System Elements		
9. CRL Adit Usage	Y	Y
10. CRL Timetable	Y	Y
11. CRL Cancelled Train Logic		
12. LU Timetable		
13. NR / Other Timetable		
14. Constraining Alighters Logic	Y	Y
15. Constraining Boarders Logic		
16. Boarding Profiles (CRL)	Y	Y
17. Boarding Profiles (LU / Other)		
18. Alighting Profiles (CRL)	Y	Y
19. Alighting Profiles (LU / Other)		
20. Boarding Logic	Y	Y
21. Dwell Time Logic	Y	Y
22. 15 Minute Profiling	Y	Y
23. TPH broken up into 15 minute periods	Y	Y
24. 15 Minute Demand to Train Services	Y	Y
25. B & A Percentages		
26. Accuracy of Seams		

Not relevant for the Bond Street Crossrail Model.



List of Input Assumptions

CRL	LU
Y	Y
Y	Y
Y	Y
Y	Y
Y	Y
Y	Y
Y	Y
Y	Y
Y	Y
Y	Y
Y	Y
Y	Y
Y	Y

INPUT 14: Constraining Alighters Logic

**Mostly Applicable in AM Peak when there are generally more Alighters than Boarders**

Step 1:

Determine the Peak Fifteen Minutes

[Define: Peak fifteen minutes]

Step 2:

Determine the CRL service in the peak fifteen minutes with the highest number of alighters that will be placed on subsequent trains following a cancellation

[Define: Direction + (from Origin)]

Choose from:

- CRL WB (from Abbey Wood)      CRL EB (from Paddington)
- CRL WB (from Shenfield)      CRL EB (from Maidenhead)
- CRL EB (from Heathrow)
- CRL EB (from West Drayton)
- CRL EB (from Ealing Broadway)

(N.B. Please ensure that the cancelled train is the first appropriate service in the Peak fifteen minutes in question, this will ensure that any effect of a cancellation is sufficiently captured in any congestion plots / outputs from the peak fifteen period in question)

Step 3:

Calculate the maximum number of alighters at any one time from a 'Direction + (from Origin)' service

[Define: Max Number of Alighters]

Step 4:

Calculate the number of alighters displaced from the cancelled train and add these appropriately to the alighters already due on subsequent train(s)

[Define: Revised Alighting Load On Subsequent Train(s)]

Step 5:

- a If Revised Alighting Load On ANY Subsequent Train  $\leq$  Max Number of Alighters then subsequent train Alighting Load = OKAY
- b If Revised Alighting Load On ANY Subsequent Train  $>$  Max Number of Alighters then subsequent train Alighting Load = Max Number of Alighters

Step 6:

If Step 5b takes precedence over Step 5a then place [ Revised Alighting Load On Subsequent Train(s) ] - [ Max Number of Alighters ] excess passengers on further appropriate subsequent trains

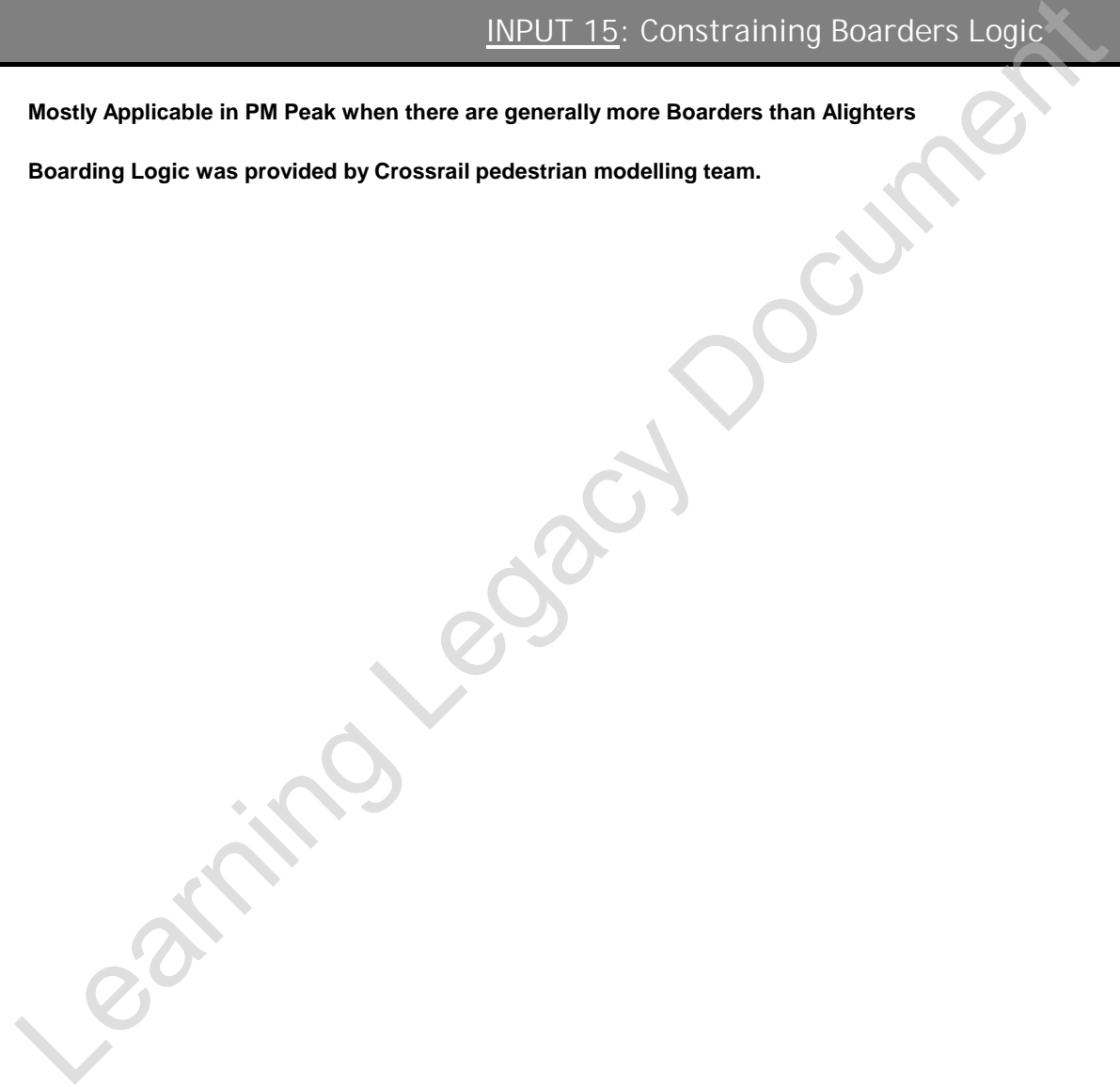
$$[Max\ Number\ of\ Alighters] = \frac{\text{Percentage of Trainload from a } [Direction + (from Origin)] \text{ Service Alighting at Whitechapel}}{\text{Capacity of a CRL Train}}$$

INPUT 15: Constraining Boarders Logic

List of Input Assumptions	CRL	LU
1. CAD (Extent of Model)	Y	Y
2. TPH	Y	Y
3. Escalator Config.		
4. Gateline Config.		
5. Ticketing		
6. PRM Routings and Rules		
7. Non-PRM Routings		
8. One-Way System Elements		
9. CRL Adit Usage	Y	Y
10. CRL Timetable	Y	Y
11. CRL Cancelled Train Logic		
12. LU Timetable		
13. NR / Other Timetable		
14. Constraining Alighters Logic	Y	Y
15. Constraining Boarders Logic		
16. Boarding Profiles (CRL)	Y	Y
17. Boarding Profiles (LU / Other)		
18. Alighting Profiles (CRL)	Y	Y
19. Alighting Profiles (LU / Other)		
20. Boarding Logic	Y	Y
21. Dwell Time Logic	Y	Y
22. 15 Minute Profiling	Y	Y
23. TPH broken up into 15 minute periods	Y	Y
24. 15 Minute Demand to Train Services	Y	Y
25. B & A Percentages		
26. Accuracy of Seams		

Mostly Applicable in PM Peak when there are generally more Boarders than Alighters

Boarding Logic was provided by Crossrail pedestrian modelling team.





List of Input Assumptions

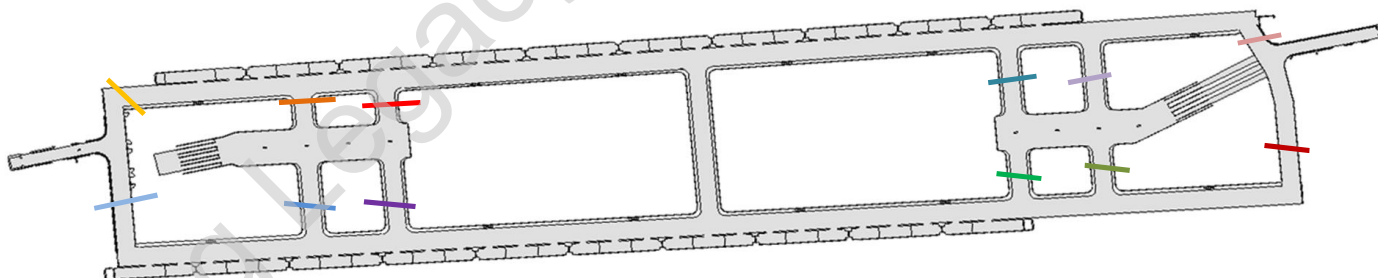
CRL LU

1. CAD (Extent of Model)	Y	Y
2. TPH	Y	Y
3. Escalator Config.		
4. Gateline Config.		
5. Ticketing		
6. PRM Routings and Rules		
7. Non-PRM Routings		
8. One-Way System Elements		
9. CRL Adit Usage	Y	Y
10. CRL Timetable	Y	Y
11. CRL Cancelled Train Logic		
12. LU Timetable		
13. NR / Other Timetable		
14. Constraining Alighters Logic	Y	Y
15. Constraining Boarders Logic		
16. Boarding Profiles (CRL)	Y	Y
17. Boarding Profiles (LU / Other)		
18. Alighting Profiles (CRL)	Y	Y
19. Alighting Profiles (LU / Other)		
20. Boarding Logic	Y	Y
21. Dwell Time Logic	Y	Y
22. 15 Minute Profiling	Y	Y
23. TPH broken up into 15 minute periods	Y	Y
24. 15 Minute Demand to Train Services	Y	Y
25. B & A Percentages		
26. Accuracy of Seams		

INPUT 16: Boarding Profiles (CRL)

CRL EB Platform Entrances

Car 10	Car 9	Car 8	Car 7	Car 6	Car 5	Car 4	Car 3	Car 2	Car 1	
40.0%	30.0%	20.0%	10.0%	0.0%	0.0%	0.0%	0.0%	0.0%	0.0%	100.0%
14.5%	16.0%	15.0%	14.0%	12.5%	10.0%	8.0%	5.5%	3.5%	1.0%	100.0%
5.0%	12.0%	16.0%	16.0%	15.0%	12.5%	11.0%	7.5%	4.5%	0.5%	100.0%
1.5%	2.5%	4.5%	7.5%	10.5%	12.5%	15.0%	15.0%	16.0%	15.0%	100.0%
1.0%	1.0%	4.0%	7.0%	10.0%	12.0%	14.0%	16.0%	17.0%	18.0%	100.0%
0.0%	0.0%	0.0%	0.0%	0.0%	0.0%	5.0%	17.5%	32.5%	45.0%	100.0%



CRL WB Platform Entrances

Car 1	Car 2	Car 3	Car 4	Car 5	Car 6	Car 7	Car 8	Car 9	Car 10	
40.0%	30.0%	20.0%	10.0%	0.0%	0.0%	0.0%	0.0%	0.0%	0.0%	100.0%
14.0%	15.0%	15.0%	14.0%	12.0%	10.0%	8.0%	6.0%	4.0%	2.0%	100.0%
4.0%	11.0%	16.0%	16.0%	15.0%	13.0%	11.0%	8.0%	5.0%	1.0%	100.0%
1.0%	1.0%	4.0%	7.0%	10.0%	12.0%	14.0%	16.0%	17.0%	18.0%	100.0%
1.0%	1.0%	4.0%	7.0%	10.0%	12.0%	14.0%	16.0%	17.0%	18.0%	100.0%
0.0%	0.0%	0.0%	0.0%	0.0%	0.0%	5.0%	17.5%	32.5%	45.0%	100.0%

List of Input Assumptions	CRL	LU	INPUT 17: Boarding Profiles (LU / Other)
1. CAD (Extent of Model)	Y	Y	<p>Not relevant for the Bond Street Crossrail Model.</p>
2. TPH	Y	Y	
3. Escalator Config.			
4. Gateline Config.			
5. Ticketing			
6. PRM Routings and Rules			
7. Non-PRM Routings			
8. One-Way System Elements			
9. CRL Adit Usage	Y	Y	
10. CRL Timetable	Y	Y	
11. CRL Cancelled Train Logic			
12. LU Timetable			
13. NR / Other Timetable			
14. Constraining Alighters Logic	Y	Y	
15. Constraining Boarders Logic			
16. Boarding Profiles (CRL)	Y	Y	
17. Boarding Profiles (LU / Other)			
18. Alighting Profiles (CRL)	Y	Y	
19. Alighting Profiles (LU / Other)			
20. Boarding Logic	Y	Y	
21. Dwell Time Logic	Y	Y	
22. 15 Minute Profiling	Y	Y	
23. TPH broken up into 15 minute periods	Y	Y	
24. 15 Minute Demand to Train Services	Y	Y	
25. B & A Percentages			
26. Accuracy of Seams			

Learning Legacy Document

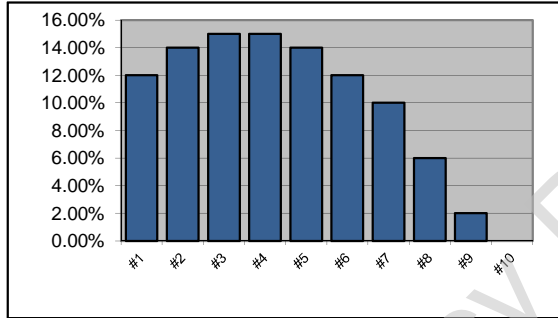
List of Input Assumptions

CRL LU

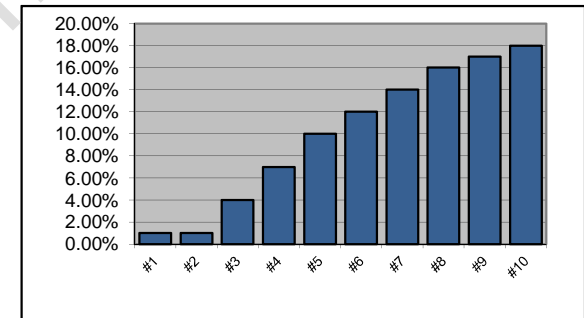
- 1. CAD (Extent of Model) Y Y
- 2. TPH Y Y
- 3. Escalator Config. Y Y
- 4. Gateline Config. Y Y
- 5. Ticketing Y Y
- 6. PRM Routings and Rules Y Y
- 7. Non-PRM Routings Y Y
- 8. One-Way System Elements Y Y
- 9. CRL Adit Usage Y Y
- 10. CRL Timetable Y Y
- 11. CRL Cancelled Train Logic Y Y
- 12. LU Timetable Y Y
- 13. NR / Other Timetable Y Y
- 14. Constraining Alighters Logic Y Y
- 15. Constraining Boarders Logic Y Y
- 16. Boarding Profiles (CRL) Y Y
- 17. Boarding Profiles (LU / Other) Y Y
- 18. Alighting Profiles (CRL) Y Y
- 19. Alighting Profiles (LU / Other) Y Y
- 20. Boarding Logic Y Y
- 21. Dwell Time Logic Y Y
- 22. 15 Minute Profiling Y Y
- 23. TPH broken up into 15 minute periods Y Y
- 24. 15 Minute Demand to Train Services Y Y
- 25. B & A Percentages Y Y
- 26. Accuracy of Seams Y Y

INPUT 18: Alighting Profiles (CRL)

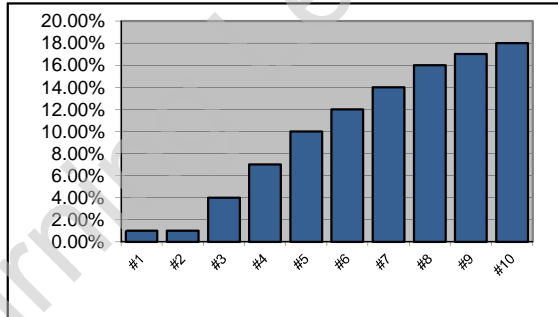
Platform Name	
CRL WB (Davies St)	
Car	%
#1	12.00%
#2	14.00%
#3	15.00%
#4	15.00%
#5	14.00%
#6	12.00%
#7	10.00%
#8	6.00%
#9	2.00%
#10	0.00%
<u>100.00%</u>	



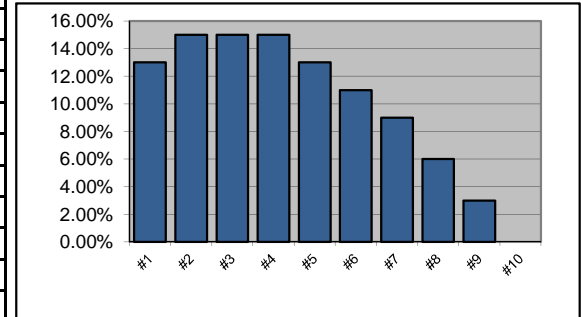
Platform Name	
CRL WB (Hanover Sq)	
Car	%
#1	1.00%
#2	1.00%
#3	4.00%
#4	7.00%
#5	10.00%
#6	12.00%
#7	14.00%
#8	16.00%
#9	17.00%
#10	18.00%
<u>100.00%</u>	



Platform Name	
CRL EB (Davies St)	
Car	%
#1	1.00%
#2	1.00%
#3	4.00%
#4	7.00%
#5	10.00%
#6	12.00%
#7	14.00%
#8	16.00%
#9	17.00%
#10	18.00%
<u>100.00%</u>	



Platform Name	
CRL EB (Hanover Sq)	
Car	%
#1	13.00%
#2	15.00%
#3	15.00%
#4	15.00%
#5	13.00%
#6	11.00%
#7	9.00%
#8	6.00%
#9	3.00%
#10	0.00%
<u>100.00%</u>	



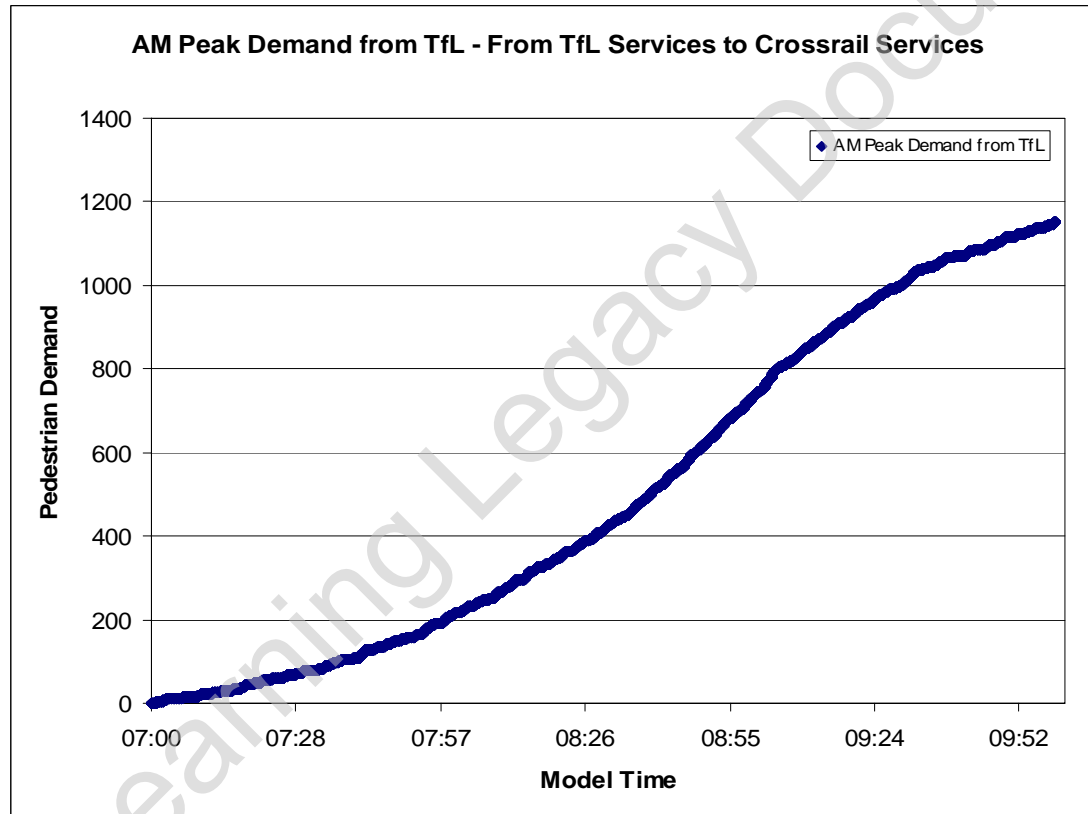
List of Input Assumptions

CRL LU

1. CAD (Extent of Model)	Y	Y
2. TPH	Y	Y
3. Escalator Config.	Y	Y
4. Gateline Config.	Y	Y
5. Ticketing	Y	Y
6. PRM Routings and Rules	Y	Y
7. Non-PRM Routings	Y	Y
8. One-Way System Elements	Y	Y
9. CRL Adit Usage	Y	Y
10. CRL Timetable	Y	Y
11. CRL Cancelled Train Logic	Y	Y
12. LU Timetable	Y	Y
13. NR / Other Timetable	Y	Y
14. Constraining Alighters Logic	Y	Y
15. Constraining Boarders Logic	Y	Y
16. Boarding Profiles (CRL)	Y	Y
17. Boarding Profiles (LU / Other)	Y	Y
18. Alighting Profiles (CRL)	Y	Y
19. Alighting Profiles (LU / Other)	Y	Y
20. Boarding Logic	Y	Y
21. Dwell Time Logic	Y	Y
22. 15 Minute Profiling	Y	Y
23. TPH broken up into 15 minute periods	Y	Y
24. 15 Minute Demand to Train Services	Y	Y
25. B & A Percentages	Y	Y
26. Accuracy of Seams	Y	Y

INPUT 19: Alighting Profiles (LU / Other)

This is the profile of demand provided by LU for the arrival of pedestrians into Bond Street Crossrail from LUL services - This has been taken from the Bond Street Upgrade Legion Model. This profile has been used and applied to the predicted demand from the LUL tunnel.  
LGM File: I:\BND Bond Street\J090xx Bond Street Modelling Assurance for RUP\BOS XRL 2017 AM\BOS XRL AM 2017\_RevB.lgm  
RES File: I:\BND Bond Street\J090xx Bond Street Modelling Assurance for RUP\BOS XRL 2017 AM\BOS XRL AM 2017\_RevB\_Base.res



List of Input Assumptions

CRL LU

INPUT 20: Boarding Logic

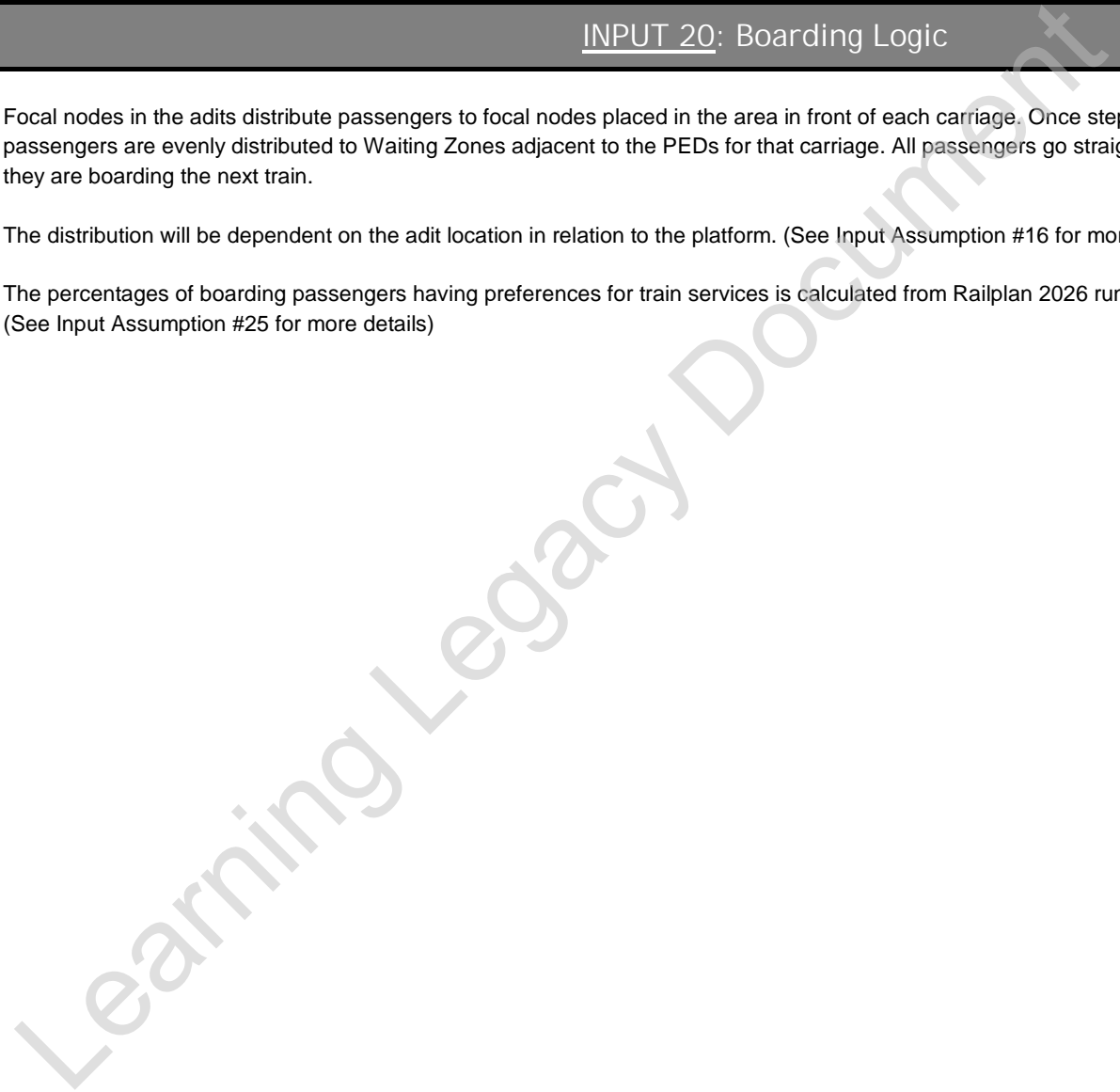
1. CAD (Extent of Model)	Y	Y
2. TPH	Y	Y
3. Escalator Config.		
4. Gateline Config.		
5. Ticketing		
6. PRM Routings and Rules		
7. Non-PRM Routings		
8. One-Way System Elements		
9. CRL Adit Usage	Y	Y
10. CRL Timetable	Y	Y
11. CRL Cancelled Train Logic		
12. LU Timetable		
13. NR / Other Timetable		
14. Constraining Alighters Logic	Y	Y
15. Constraining Boarders Logic		
16. Boarding Profiles (CRL)	Y	Y
17. Boarding Profiles (LU / Other)		
18. Alighting Profiles (CRL)	Y	Y
19. Alighting Profiles (LU / Other)		
20. Boarding Logic	Y	Y
21. Dwell Time Logic	Y	Y
22. 15 Minute Profiling	Y	Y
23. TPH broken up into 15 minute periods	Y	Y
24. 15 Minute Demand to Train Services	Y	Y
25. B & A Percentages		
26. Accuracy of Seams		

Focal nodes in the adits distribute passengers to focal nodes placed in the area in front of each carriage. Once stepped inside these carriage focal nodes passengers are evenly distributed to Waiting Zones adjacent to the PEDs for that carriage. All passengers go straight to the PEDs regardless of whether or not they are boarding the next train.

The distribution will be dependent on the adit location in relation to the platform. (See Input Assumption #16 for more details)

The percentages of boarding passengers having preferences for train services is calculated from Railplan 2026 run:  
(See Input Assumption #25 for more details)

XR153Ru



List of Input Assumptions

CRL LU

INPUT 21: Dwell Time Logic

1. CAD (Extent of Model)	Y	Y
2. TPH	Y	Y
3. Escalator Config.		
4. Gatetime Config.		
5. Ticketing		
6. PRM Routings and Rules		
7. Non-PRM Routings		
8. One-Way System Elements		
9. CRL Adit Usage	Y	Y
10. CRL Timetable	Y	Y
11. CRL Cancelled Train Logic		
12. LU Timetable		
13. NR / Other Timetable		
14. Constraining Alighters Logic	Y	Y
15. Constraining Boarders Logic		
16. Boarding Profiles (CRL)	Y	Y
17. Boarding Profiles (LU / Other)		
18. Alighting Profiles (CRL)	Y	Y
19. Alighting Profiles (LU / Other)		
20. Boarding Logic	Y	Y
21. Dwell Time Logic	Y	Y
22. 15 Minute Profiling	Y	Y
23. TPH broken up into 15 minute periods	Y	Y
24. 15 Minute Demand to Train Services	Y	Y
25. B & A Percentages		
26. Accuracy of Seams		

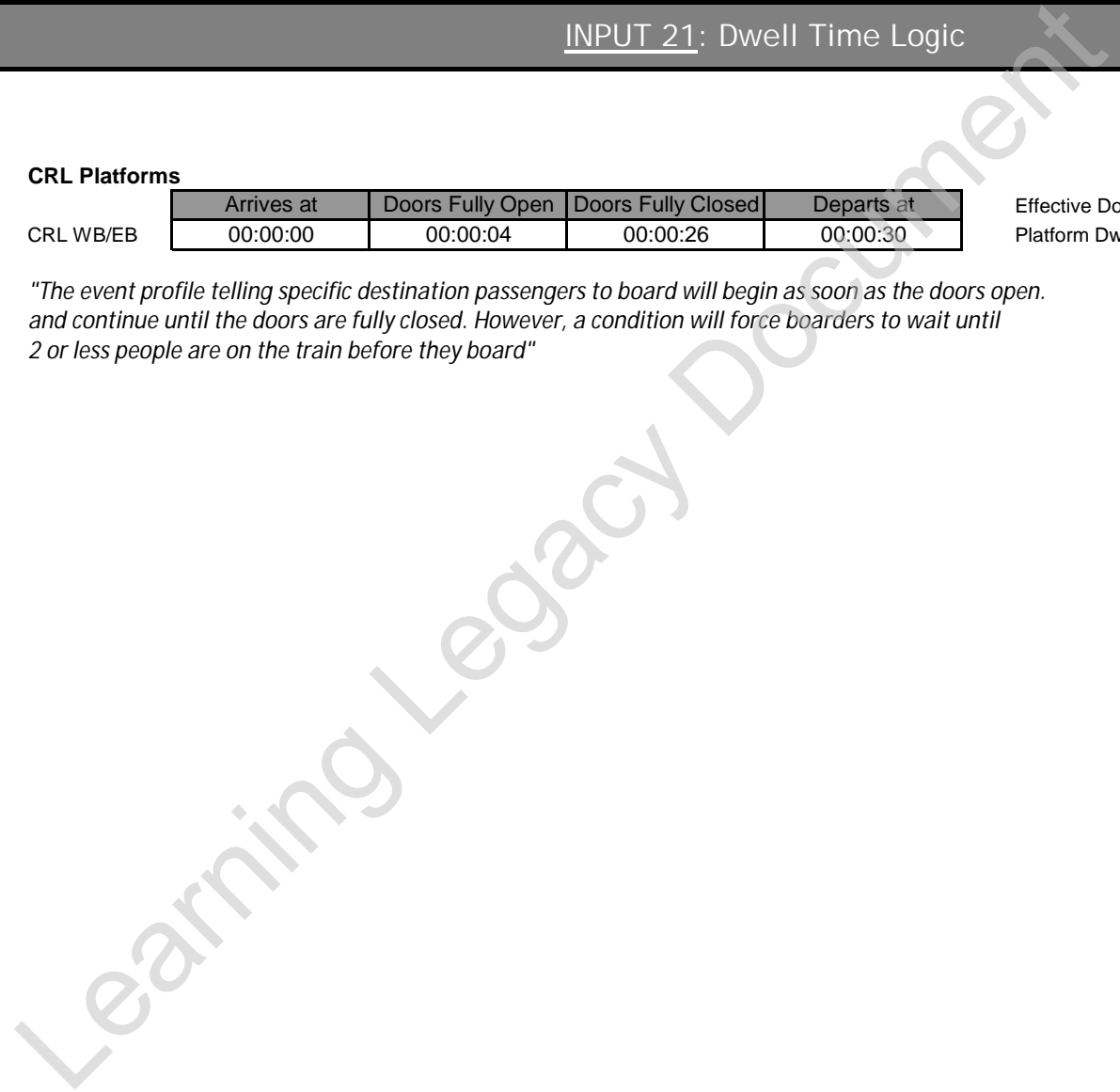
CRL Platforms

	Arrives at	Doors Fully Open	Doors Fully Closed	Departs at
CRL WB/EB	00:00:00	00:00:04	00:00:26	00:00:30

Effective Door Opening Time  
Platform Dwell Time

00:00:22
00:00:30

"The event profile telling specific destination passengers to board will begin as soon as the doors open. and continue until the doors are fully closed. However, a condition will force boarders to wait until 2 or less people are on the train before they board"





List of Input Assumptions

CRL LU

INPUT 23: TPH broken up 15 into minute periods

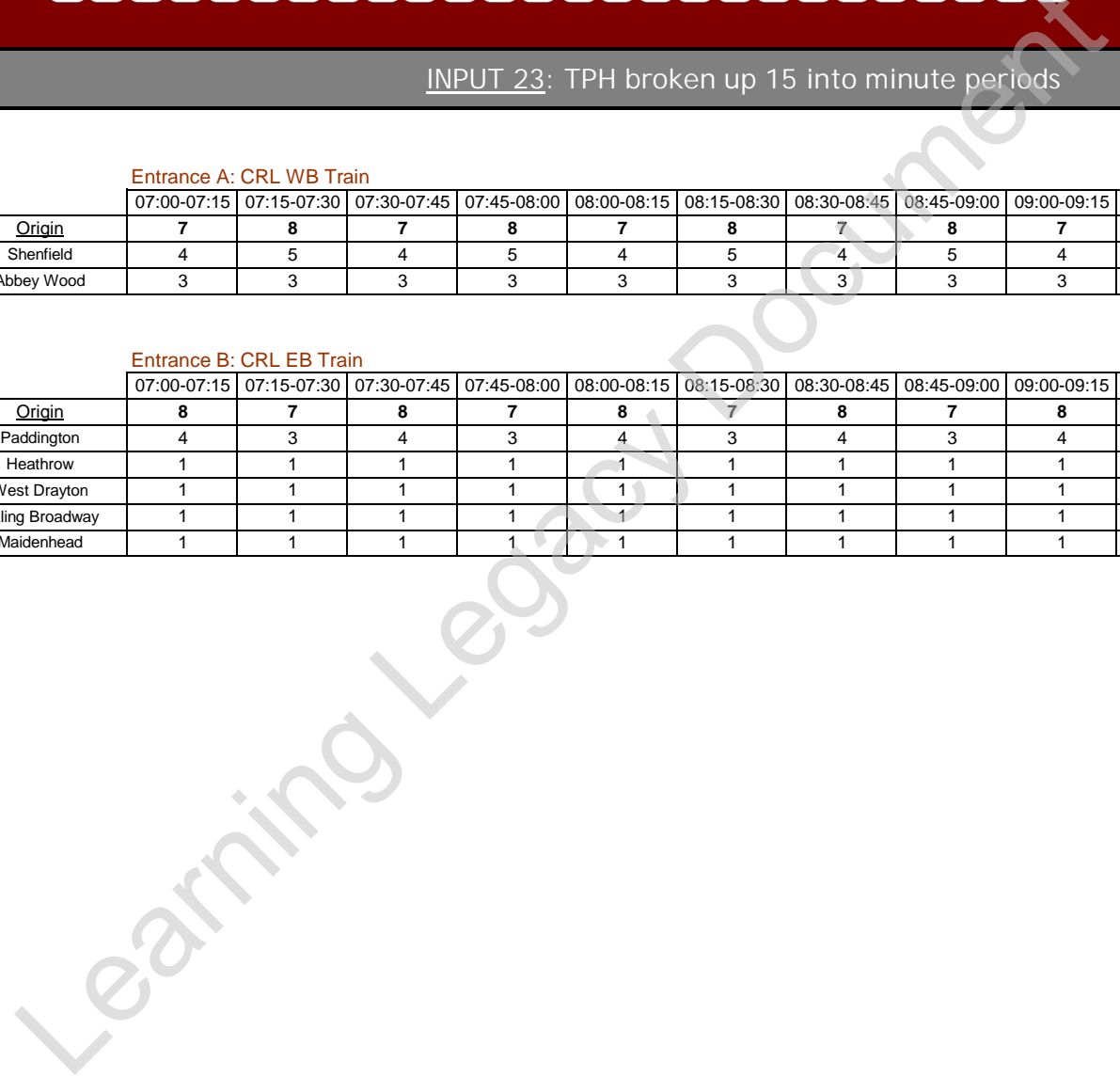
- 1. CAD (Extent of Model) Y Y
- 2. TPH Y Y
- 3. Escalator Config. Y
- 4. Gateline Config. Y
- 5. Ticketing Y
- 6. PRM Routings and Rules Y
- 7. Non-PRM Routings Y
- 8. One-Way System Elements Y
- 9. CRL Adit Usage Y Y
- 10. CRL Timetable Y Y
- 11. CRL Cancelled Train Logic Y Y
- 12. LU Timetable Y
- 13. NR / Other Timetable Y
- 14. Constraining Alighters Logic Y Y
- 15. Constraining Boarders Logic Y
- 16. Boarding Profiles (CRL) Y Y
- 17. Boarding Profiles (LU / Other) Y
- 18. Alighting Profiles (CRL) Y Y
- 19. Alighting Profiles (LU / Other) Y
- 20. Boarding Logic Y Y
- 21. Dwell Time Logic Y Y
- 22. 15 Minute Profiling Y Y
- 23. TPH broken up into 15 minute periods Y Y
- 24. 15 Minute Demand to Train Services Y Y
- 25. B & A Percentages Y
- 26. Accuracy of Seams Y

Entrance A: CRL WB Train

	07:00-07:15	07:15-07:30	07:30-07:45	07:45-08:00	08:00-08:15	08:15-08:30	08:30-08:45	08:45-09:00	09:00-09:15	09:15-09:30	09:30-09:45	09:45-10:00
<u>Origin</u>	7	8	7	8	7	8	7	8	7	8	7	8
Shenfield	4	5	4	5	4	5	4	5	4	5	4	5
Abbey Wood	3	3	3	3	3	3	3	3	3	3	3	3

Entrance B: CRL EB Train

	07:00-07:15	07:15-07:30	07:30-07:45	07:45-08:00	08:00-08:15	08:15-08:30	08:30-08:45	08:45-09:00	09:00-09:15	09:15-09:30	09:30-09:45	09:45-10:00
<u>Origin</u>	8	7	8	7	8	7	8	7	8	7	8	7
Paddington	4	3	4	3	4	3	4	3	4	3	4	3
Heathrow	1	1	1	1	1	1	1	1	1	1	1	1
West Drayton	1	1	1	1	1	1	1	1	1	1	1	1
Ealing Broadway	1	1	1	1	1	1	1	1	1	1	1	1
Maidenhead	1	1	1	1	1	1	1	1	1	1	1	1





INPUT 24: 15 Minute Demand to Train Services

List of Input Assumptions

CRL U

- 1. CAD (Extent of Model) Y Y
- 2. TPH Y Y
- 3. Escalator Config. Y
- 4. GateLine Config. Y
- 5. Ticketing Y
- 6. PRM Routings and Rules Y
- 7. Non-PRM Routings Y
- 8. One-Way System Elements Y
- 9. CRL Adit Usage Y Y
- 10. CRL Timetable Y Y
- 11. CRL Cancelled Train Logic Y
- 12. LU Timetable Y
- 13. NR / Other Timetable Y
- 14. Constraining Alighters Logic Y Y
- 15. Constraining Boarders Logic Y Y
- 16. Boarding Profiles (CRL) Y Y
- 17. Boarding Profiles (LU / Other) Y Y
- 18. Alighting Profiles (CRL) Y Y
- 19. Alighting Profiles (LU / Other) Y Y
- 20. Boarding Logic Y Y
- 21. Dwell Time Logic Y Y
- 22. 15 Minute Profiling Y Y
- 23. TPH broken up into 15 minute periods Y Y
- 24. 15 Minute Demand to Train Services Y Y
- 25. B & A Percentages Y
- 26. Accuracy of Seams Y

Entrance A: CRL WB Train

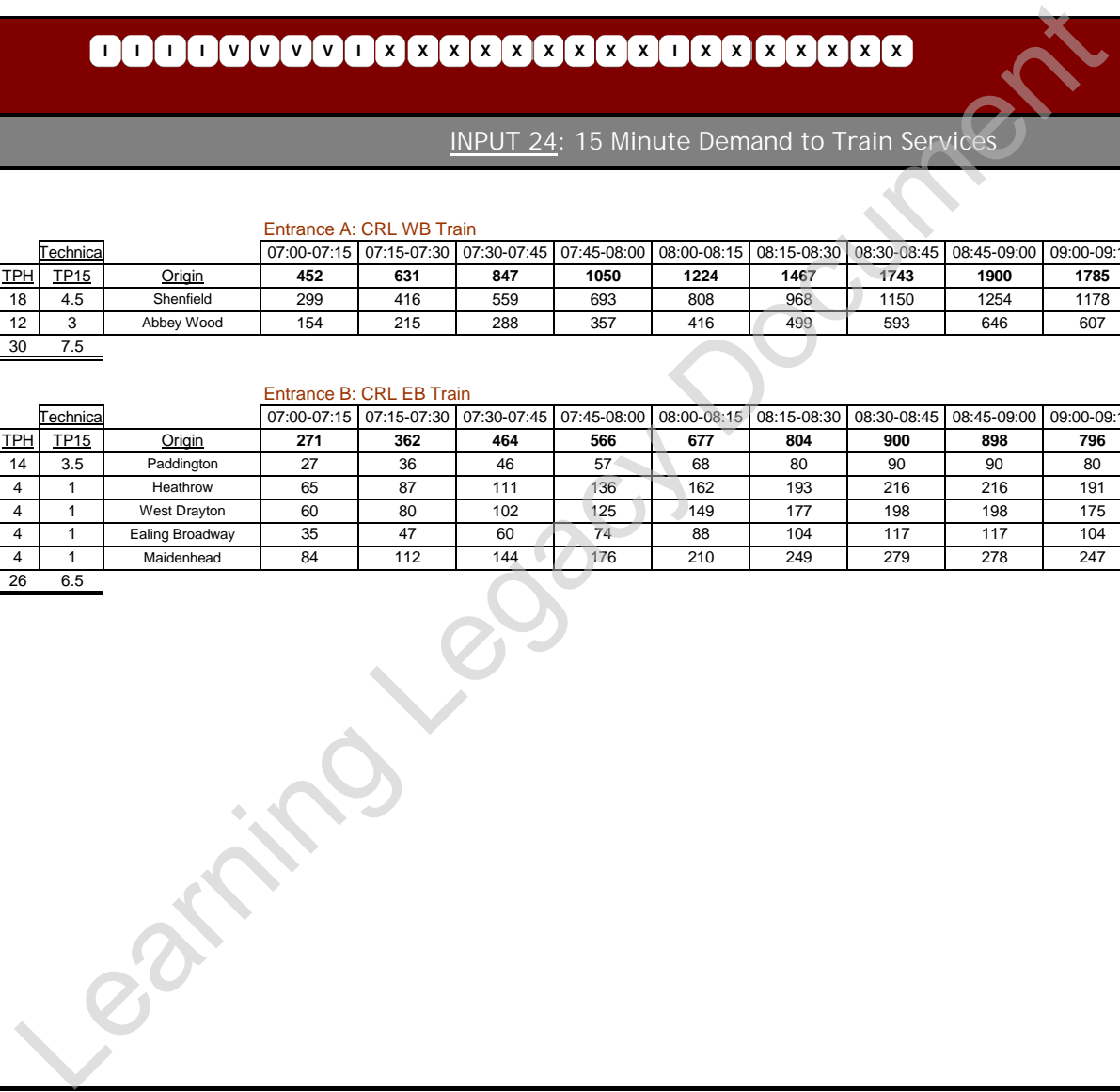
			Technica													
Popularity	TPH	TP15	Origin	07:00-07:15	07:15-07:30	07:30-07:45	07:45-08:00	08:00-08:15	08:15-08:30	08:30-08:45	08:45-09:00	09:00-09:15	09:15-09:30	09:30-09:45	09:45-10:00	
66%	18	4.5	Shenfield	452	631	847	1050	1224	1467	1743	1900	1785	1525	1266	1085	14976
34%	12	3	Abbey Wood	299	416	559	693	808	968	1150	1254	1178	1006	836	716	
100%	30	7.5														

Entrance B: CRL EB Train

			Technica													
Popularity	TPH	TP15	Origin	07:00-07:15	07:15-07:30	07:30-07:45	07:45-08:00	08:00-08:15	08:15-08:30	08:30-08:45	08:45-09:00	09:00-09:15	09:15-09:30	09:30-09:45	09:45-10:00	
10%	14	3.5	Paddington	271	362	464	566	677	804	900	898	796	665	553	467	7424
24%	4	1	Heathrow	27	36	46	57	68	80	90	90	80	67	55	47	
22%	4	1	West Drayton	65	87	111	136	162	193	216	216	191	160	133	112	
13%	4	1	Ealing Broadway	60	80	102	125	149	177	198	198	175	146	122	103	
31%	4	1	Maidenhead	35	47	60	74	88	104	117	117	104	86	72	61	
100%	26	6.5														

14976

7424



List of Input Assumptions	CRL	LU
1. CAD (Extent of Model)	Y	Y
2. TPH	Y	Y
3. Escalator Config.	Y	Y
4. Gateline Config.	Y	Y
5. Ticketing	Y	Y
6. PRM Routings and Rules	Y	Y
7. Non-PRM Routings	Y	Y
8. One-Way System Elements	Y	Y
9. CRL Adit Usage	Y	Y
10. CRL Timetable	Y	Y
11. CRL Cancelled Train Logic	Y	Y
12. LU Timetable	Y	Y
13. NR / Other Timetable	Y	Y
14. Constraining Alighters Logic	Y	Y
15. Constraining Boarders Logic	Y	Y
16. Boarding Profiles (CRL)	Y	Y
17. Boarding Profiles (LU / Other)	Y	Y
18. Alighting Profiles (CRL)	Y	Y
19. Alighting Profiles (LU / Other)	Y	Y
20. Boarding Logic	Y	Y
21. Dwell Time Logic	Y	Y
22. 15 Minute Profiling	Y	Y
23. TPH broken up into 15 minute periods	Y	Y
24. 15 Minute Demand to Train Services	Y	Y
25. B & A Percentages	Y	Y
26. Accuracy of Seams	Y	Y

INPUT 25: B & A Percentages

Railplan Source:  (2026XR)

**CRL**  
Boarding Percentages

CRL WB Any (Destination is Bond Street or Paddington)	9%
CRL WB Any Post Ealing-WD (Destination is stations between Ealing Broadway and West Drayton)	31%
CRL WB Any Post PAD-Ealing (Destination is stations between Paddington and Ealing Broadway)	25%
CRL WB Heathrow (Destination is Heathrow Airport)	10%
CRL WB Any Post WD-MAID (Destination is stations between West Drayton and Maidenhead)	25%
<b>100%</b>	

CRL EB Any (Destination is any station between Farringdon and Whitechapel)	17%
CRL EB Shenfield (Destination is any station on the Shenfield Branch)	24%
CRL EB Abbey Wood (Destination is any station on the Abbey Wood Branch)	59%
<b>100%</b>	

Alighting Percentages

Split of CRL WB Alighters originating from a Shenfield Service	66.0%
Split of CRL WB Alighters originating from a Abbey Wood Service	34.0%
<b>100%</b>	
Split of CRL EB Alighters originating from a Paddington Service	10.0%
Split of CRL EB Alighters originating from a Heathrow Service	24.0%
Split of CRL EB Alighters originating from a West Drayton Service	22.0%
Split of CRL EB Alighters originating from a Maidenhead Service	31.0%
Split of CRL EB Alighters originating from an Ealing Broadway Service	13.0%
<b>100%</b>	

Train Load Percentages (for assistance with logic around impact on Cancelled Train)

Percentage of a WB train load from Shenfield alighting at Whitechapel	
Percentage of a WB train load from Abbey Wood alighting at Whitechapel	
Percentage of a WB train load from Paddington alighting at Whitechapel	
Percentage of a WB train load from Heathrow alighting at Whitechapel	
Percentage of a WB train load from West Drayton alighting at Whitechapel	
Percentage of a WB train load from Ealing Broadway alighting at Whitechapel	
Percentage of a WB train load from Maidenhead alighting at Whitechapel	

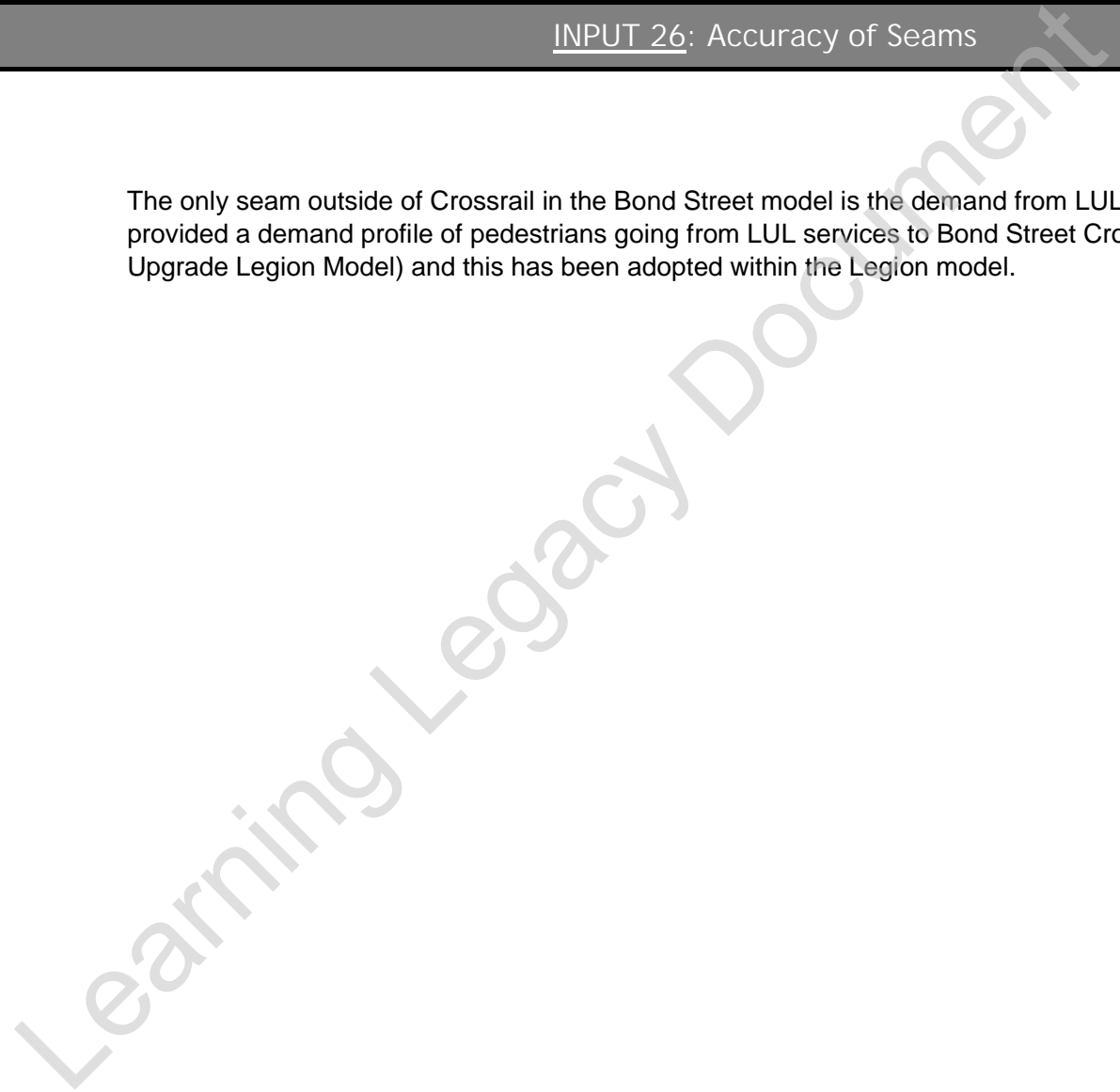
List of Input Assumptions

CRL LU

INPUT 26: Accuracy of Seams

1. CAD (Extent of Model)	Y	Y
2. TPH	Y	Y
3. Escalator Config.		
4. Gateline Config.		
5. Ticketing		
6. PRM Routings and Rules		
7. Non-PRM Routings		
8. One-Way System Elements		
9. CRL Adit Usage	Y	Y
10. CRL Timetable	Y	Y
11. CRL Cancelled Train Logic		
12. LU Timetable		
13. NR / Other Timetable		
14. Constraining Alighters Logic	Y	Y
15. Constraining Boarders Logic		
16. Boarding Profiles (CRL)	Y	Y
17. Boarding Profiles (LU / Other)		
18. Alighting Profiles (CRL)	Y	Y
19. Alighting Profiles (LU / Other)		
20. Boarding Logic	Y	Y
21. Dwell Time Logic	Y	Y
22. 15 Minute Profiling	Y	Y
23. TPH broken up into 15 minute periods	Y	Y
24. 15 Minute Demand to Train Services	Y	Y
25. B & A Percentages		
26. Accuracy of Seams		

The only seam outside of Crossrail in the Bond Street model is the demand from LUL services. LU have provided a demand profile of pedestrians going from LUL services to Bond Street Crossrail (from the Bond Street Upgrade Legion Model) and this has been adopted within the Legion model.



List of Input Assumptions

CRL LU

INPUT 27: PRM Types and Proportions

1. CAD (Extent of Model)

Y Y

2. TPH

Y Y

3. Escalator Config.

4. Gateline Config.

5. Ticketing

6. PRM Routings and Rules

7. Non-PRM Routings

8. One-Way System Elements

9. CRL Adit Usage

Y Y

10. CRL Timetable

Y Y

11. CRL Cancelled Train Logic

12. LU Timetable

13. NR / Other Timetable

14. Constraining Alighters Logic

Y Y

15. Constraining Boarders Logic

16. Boarding Profiles (CRL)

Y Y

17. Boarding Profiles (LU / Other)

18. Alighting Profiles (CRL)

Y Y

19. Alighting Profiles (LU / Other)

20. Boarding Logic

Y Y

21. Dwell Time Logic

Y Y

22. 15 Minute Profiling

Y Y

23. TPH broken up into 15 minute periods

Y Y

24. 15 Minute Demand to Train Services

Y Y

25. B & A Percentages

Y Y

26. Accuracy of Seams

27. PRM Types and Proportions

This is taken from the Multi-Disciplinary Consultant Works Package 2 Bond St Crossrail Station - Legion Modeeling Report  
Bond St - SD3 Legion Modelling Report (ARUP)  
Document Number: CR-SD-BOS-CE-RT-00011

Table 9: 2016 PRM Types and proportions

Physically impaired			Encumbered			
Wheelchair User	Disabled	Elderly Impaired	Adults with Young Children	Heavy Shopping Bags	Medium Luggage	Large Luggage Items
A	B	B	E	C	C	D
0.010%	0.529%	0.389%	0.348%	1.020%	1.000%	0.405%
0.928%			2.773%			
3.701%						

BOND STREET

CRL WB Platform - AM Peak - 2026+28% - 30 TPH

Descriptive Stats

Peak Period	AM Peak
Future Year	2026+28%
Trains Per Hour	30

07:00 to 10:00

CRL	90	100.00%	10	99
		0.00%		
		0.00%		
Total	90			

07:00 to 08:00

CRL	30	100.00%	10	39
		0.00%		
		0.00%		
Total	30			

08:00 to 09:00

CRL	30	100.00%	40	69
		0.00%		
		0.00%		
Total	30			

09:00 to 10:00

CRL	30	100.00%	70	99
		0.00%		
		0.00%		
Total	30			

	Origin	Destination
CRL	07:01:24	07:01:54 Shenfield Paddington
CRL	07:03:45	07:04:15 Shenfield Maidenhead
CRL	07:05:27	07:05:57 Abbey Wood Heathrow
CRL	07:07:18	07:07:48 Shenfield Paddington
CRL	07:09:48	07:10:18 Abbey Wood West Drayton
CRL	07:11:39	07:12:09 Shenfield Ealing Broadway
CRL	07:13:41	07:14:11 Shenfield Paddington
CRL	07:15:38	07:16:08 Abbey Wood Paddington
CRL	07:17:48	07:18:18 Shenfield Heathrow
CRL	07:19:18	07:19:48 Abbey Wood Maidenhead
CRL	07:21:24	07:21:54 Shenfield Paddington
CRL	07:23:20	07:23:50 Shenfield West Drayton
CRL	07:25:19	07:25:49 Abbey Wood Paddington
CRL	07:27:17	07:27:47 Shenfield Ealing Broadway
CRL	07:29:28	07:29:58 Abbey Wood Paddington
CRL	07:31:42	07:32:12 Shenfield Paddington
CRL	07:33:27	07:33:57 Shenfield Maidenhead
CRL	07:35:20	07:35:50 Abbey Wood Heathrow
CRL	07:37:32	07:38:02 Shenfield Paddington
CRL	07:39:26	07:39:56 Abbey Wood West Drayton
CRL	07:41:48	07:42:18 Shenfield Ealing Broadway
CRL	07:43:27	07:43:57 Shenfield Paddington
CRL	07:45:15	07:45:45 Abbey Wood Paddington
CRL	07:47:41	07:48:11 Shenfield Heathrow
CRL	07:49:45	07:50:15 Abbey Wood Maidenhead
CRL	07:51:18	07:51:48 Shenfield Paddington
CRL	07:53:53	07:54:23 Shenfield West Drayton
CRL	07:55:29	07:55:59 Abbey Wood Paddington
CRL	07:57:40	07:58:10 Shenfield Paddington
CRL	07:59:18	07:59:48 Abbey Wood Ealing Broadway
CRL	08:01:16	08:01:46 Shenfield Paddington
CRL	08:03:45	08:04:15 Shenfield Maidenhead
CRL	08:06:01	08:06:31 Abbey Wood Heathrow
CRL	08:07:20	08:07:50 Shenfield Paddington
CRL	08:09:17	08:09:47 Abbey Wood West Drayton
CRL	08:11:27	08:11:57 Shenfield Ealing Broadway
CRL	08:13:45	08:14:15 Shenfield Paddington
CRL	08:15:45	08:16:15 Abbey Wood Paddington
CRL	08:17:34	08:18:04 Shenfield Heathrow
CRL	08:19:23	08:19:53 Abbey Wood Maidenhead
CRL	08:21:42	08:22:12 Shenfield Paddington
CRL	08:23:49	08:24:19 Shenfield West Drayton
CRL	08:25:29	08:25:59 Abbey Wood Paddington
CRL	08:27:26	08:27:56 Shenfield Ealing Broadway
CRL	08:29:28	08:29:58 Abbey Wood Paddington
CRL	08:31:28	08:31:58 Shenfield Paddington
CRL	08:33:19	08:33:49 Shenfield Maidenhead
CRL	08:36:02	08:36:32 Abbey Wood Heathrow
CRL	08:37:21	08:37:51 Shenfield Paddington
CRL	08:39:19	08:39:49 Abbey Wood West Drayton
CRL	08:41:24	08:41:54 Shenfield Ealing Broadway
CRL	08:43:42	08:44:12 Shenfield Paddington
CRL	08:45:18	08:45:48 Abbey Wood Paddington
CRL	08:47:19	08:47:49 Shenfield Heathrow
CRL	08:49:10	08:49:40 Abbey Wood Maidenhead
CRL	08:52:05	08:52:35 Shenfield Paddington
CRL	08:53:46	08:54:16 Shenfield West Drayton
CRL	08:56:02	08:56:32 Abbey Wood Paddington
CRL	08:57:59	08:58:29 Shenfield Paddington
CRL	08:59:29	08:59:59 Abbey Wood Ealing Broadway
CRL	09:01:23	09:01:53 Shenfield Paddington
CRL	09:03:26	09:03:56 Shenfield Maidenhead
CRL	09:05:33	09:06:03 Abbey Wood Heathrow
CRL	09:07:19	09:07:49 Shenfield Paddington
CRL	09:09:37	09:10:07 Abbey Wood West Drayton
CRL	09:11:30	09:12:00 Shenfield Ealing Broadway
CRL	09:13:47	09:14:17 Shenfield Paddington
CRL	09:15:35	09:16:05 Abbey Wood Paddington
CRL	09:17:17	09:17:47 Shenfield Heathrow
CRL	09:19:19	09:19:49 Abbey Wood Maidenhead
CRL	09:21:26	09:21:56 Shenfield Paddington
CRL	09:23:27	09:23:57 Shenfield West Drayton
CRL	09:25:46	09:26:16 Abbey Wood Paddington
CRL	09:27:32	09:28:02 Shenfield Ealing Broadway
CRL	09:29:26	09:29:56 Abbey Wood Paddington
CRL	09:31:27	09:31:57 Shenfield Paddington
CRL	09:33:29	09:33:59 Shenfield Maidenhead
CRL	09:36:05	09:36:35 Abbey Wood Heathrow
CRL	09:37:55	09:38:25 Shenfield Paddington
CRL	09:39:43	09:40:13 Abbey Wood West Drayton
CRL	09:41:40	09:42:10 Shenfield Ealing Broadway
CRL	09:43:51	09:44:21 Shenfield Paddington
CRL	09:45:16	09:45:46 Abbey Wood Paddington
CRL	09:48:00	09:48:30 Shenfield Heathrow
CRL	09:50:00	09:50:30 Abbey Wood Maidenhead
CRL	09:52:02	09:52:32 Shenfield Paddington
CRL	09:53:23	09:53:53 Shenfield West Drayton
CRL	09:55:29	09:55:59 Abbey Wood Paddington
CRL	09:57:23	09:57:53 Shenfield Paddington
CRL	09:59:29	09:59:59 Abbey Wood Ealing Broadway

BOND STREET

CRL EB Platform - AM Peak - 2026+28% - 30 TPH

Descriptive Stats

Peak Period	AM Peak
Future Year	2026+28%
Trains Per Hour	30

	Origin	Destination
CRL	07:00:35	07:01:05 Paddington Shenfield
CRL	07:02:22	07:02:52 Maidenhead Shenfield
CRL	07:04:17	07:04:47 Heathrow Abbey Wood
CRL	07:06:30	07:07:00 Paddington Shenfield
CRL	07:08:41	07:09:11 West Drayton Abbey Wood
CRL	07:10:20	07:10:50 Ealing Broadway Shenfield
CRL	07:12:58	07:13:28 Paddington Shenfield
CRL	07:14:30	07:15:00 Paddington Abbey Wood
CRL	07:16:25	07:16:55 Heathrow Shenfield
CRL	07:18:16	07:18:46 Maidenhead Abbey Wood
CRL	07:20:37	07:21:07 Paddington Shenfield
CRL	07:22:17	07:22:47 West Drayton Shenfield
CRL	07:24:22	07:24:52 Paddington Abbey Wood
CRL	07:26:25	07:26:55 Ealing Broadway Shenfield
CRL	07:28:56	07:29:26 Paddington Abbey Wood
CRL	07:30:26	07:30:56 Paddington Shenfield
CRL	07:32:48	07:33:18 Maidenhead Shenfield
CRL	07:34:16	07:34:46 Heathrow Abbey Wood
CRL	07:36:40	07:37:10 Paddington Shenfield
CRL	07:38:52	07:39:22 West Drayton Abbey Wood
CRL	07:40:20	07:40:50 Ealing Broadway Shenfield
CRL	07:42:58	07:43:28 Paddington Shenfield
CRL	07:44:20	07:44:50 Paddington Abbey Wood
CRL	07:46:20	07:46:50 Heathrow Shenfield
CRL	07:48:57	07:49:27 Maidenhead Abbey Wood
CRL	07:51:01	07:51:31 Paddington Shenfield
CRL	07:52:39	07:53:09 West Drayton Shenfield
CRL	07:54:27	07:54:57 Paddington Abbey Wood
CRL	07:56:20	07:56:50 Paddington Shenfield
CRL	07:58:17	07:58:47 Ealing Broadway Abbey Wood
CRL	08:00:30	08:01:00 Paddington Shenfield
CRL	08:02:16	08:02:46 Maidenhead Shenfield
CRL	08:04:26	08:04:56 Heathrow Abbey Wood
CRL	08:06:51	08:07:21 Paddington Shenfield
CRL	08:09:00	08:09:30 West Drayton Abbey Wood
CRL	08:10:20	08:10:50 Ealing Broadway Shenfield
CRL	08:12:22	08:12:52 Paddington Shenfield
CRL	08:14:19	08:14:49 Paddington Abbey Wood
CRL	08:16:23	08:16:53 Heathrow Shenfield
CRL	08:18:32	08:19:02 Maidenhead Abbey Wood
CRL	08:20:27	08:20:57 Paddington Shenfield
CRL	08:22:15	08:22:45 West Drayton Shenfield
CRL	08:24:40	08:25:10 Paddington Abbey Wood
CRL	08:26:21	08:26:51 Ealing Broadway Shenfield
CRL	08:29:02	08:29:32 Paddington Abbey Wood
CRL	08:30:43	08:31:13 Paddington Shenfield
CRL	08:32:55	08:33:25 Maidenhead Shenfield
CRL	08:35:03	08:35:33 Heathrow Abbey Wood
CRL	08:37:04	08:37:34 Paddington Shenfield
CRL	08:38:58	08:39:28 West Drayton Abbey Wood
CRL	08:41:05	08:41:35 Ealing Broadway Shenfield
CRL	08:43:00	08:43:30 Paddington Shenfield
CRL	08:44:17	08:44:47 Paddington Abbey Wood
CRL	08:46:17	08:46:47 Heathrow Shenfield
CRL	08:48:59	08:49:29 Maidenhead Abbey Wood
CRL	08:50:26	08:50:56 Paddington Shenfield
CRL	08:52:16	08:52:46 West Drayton Shenfield
CRL	08:54:38	08:55:08 Paddington Abbey Wood
CRL	08:56:45	08:57:15 Paddington Shenfield
CRL	08:58:16	08:58:46 Ealing Broadway Abbey Wood
CRL	09:01:01	09:01:31 Paddington Shenfield
CRL	09:02:29	09:02:59 Maidenhead Shenfield
CRL	09:04:21	09:04:51 Heathrow Abbey Wood
CRL	09:06:16	09:06:46 Paddington Shenfield
CRL	09:08:26	09:08:56 West Drayton Abbey Wood
CRL	09:11:00	09:11:30 Ealing Broadway Shenfield
CRL	09:12:29	09:12:59 Paddington Shenfield
CRL	09:14:32	09:15:02 Paddington Abbey Wood
CRL	09:16:19	09:16:49 Heathrow Shenfield
CRL	09:18:20	09:18:50 Maidenhead Abbey Wood
CRL	09:20:20	09:20:50 Paddington Shenfield
CRL	09:22:30	09:23:00 West Drayton Shenfield
CRL	09:24:16	09:24:46 Paddington Abbey Wood
CRL	09:26:25	09:26:55 Ealing Broadway Shenfield
CRL	09:28:15	09:28:45 Paddington Abbey Wood
CRL	09:30:36	09:31:06 Paddington Shenfield
CRL	09:32:29	09:32:59 Maidenhead Shenfield
CRL	09:34:30	09:35:00 Heathrow Abbey Wood
CRL	09:36:17	09:36:47 Paddington Shenfield
CRL	09:38:26	09:38:56 West Drayton Abbey Wood
CRL	09:40:59	09:41:29 Ealing Broadway Shenfield
CRL	09:42:19	09:42:49 Paddington Shenfield
CRL	09:44:19	09:44:49 Paddington Abbey Wood
CRL	09:46:38	09:47:08 Heathrow Shenfield
CRL	09:48:16	09:48:46 Maidenhead Abbey Wood
CRL	09:50:55	09:51:25 Paddington Shenfield
CRL	09:52:25	09:52:55 West Drayton Shenfield
CRL	09:54:26	09:54:56 Paddington Abbey Wood
CRL	09:56:24	09:56:54 Paddington Shenfield
CRL	09:58:20	09:58:50 Ealing Broadway Abbey Wood

07:00 to 10:00

CRL	90	100.00%	10	99
		0.00%		
		0.00%		
Total	90			

07:00 to 08:00

CRL	30	100.00%	10	39
		0.00%		
		0.00%		
Total	30			

08:00 to 09:00

CRL	30	100.00%	40	69
		0.00%		
		0.00%		
Total	30			

09:00 to 10:00

CRL	30	100.00%	70	99
		0.00%		
		0.00%		
Total	30			

BOND STREET

CRL WB Platform - PM Peak - 2026+28% - 30 TPH

Descriptive Stats	
Peak Period	PM Peak
Future Year	2026+28%
Trains Per Hour	30

07:00 to 10:00		
	\$B\$10:\$B\$99	
CRL	90	100.00%
		0.00%
		0.00%
<b>Total</b>	<b>90</b>	

07:00 to 08:00		
	\$B\$10:\$B\$39	
CRL	30	100.00%
		0.00%
		0.00%
<b>Total</b>	<b>30</b>	

08:00 to 09:00		
	\$B\$40:\$B\$69	
CRL	30	100.00%
		0.00%
		0.00%
<b>Total</b>	<b>30</b>	

09:00 to 10:00		
	\$B\$70:\$B\$99	
CRL	30	100.00%
		0.00%
		0.00%
<b>Total</b>	<b>30</b>	

		Origin	Destination
CRL	16:01:41	Shenfield	Paddington
CRL	16:03:29	Shenfield	Maidenhead
CRL	16:05:29	Abbey Wood	Heathrow
CRL	16:07:28	Shenfield	Paddington
CRL	16:09:41	Abbey Wood	West Drayton
CRL	16:11:20	Shenfield	Ealing Broadway
CRL	16:13:28	Shenfield	Paddington
CRL	16:15:21	Abbey Wood	Paddington
CRL	16:17:18	Shenfield	Heathrow
CRL	16:19:18	Abbey Wood	Maidenhead
CRL	16:21:22	Shenfield	Paddington
CRL	16:23:27	Shenfield	West Drayton
CRL	16:25:52	Abbey Wood	Paddington
CRL	16:27:35	Shenfield	Ealing Broadway
CRL	16:29:21	Abbey Wood	Paddington
CRL	16:31:58	Shenfield	Paddington
CRL	16:33:25	Shenfield	Maidenhead
CRL	16:35:23	Abbey Wood	Heathrow
CRL	16:37:26	Shenfield	Paddington
CRL	16:39:18	Abbey Wood	West Drayton
CRL	16:41:15	Shenfield	Ealing Broadway
CRL	16:43:53	Shenfield	Paddington
CRL	16:45:45	Abbey Wood	Paddington
CRL	16:47:16	Shenfield	Heathrow
CRL	16:49:25	Abbey Wood	Maidenhead
CRL	16:51:16	Shenfield	Paddington
CRL	16:53:23	Shenfield	West Drayton
CRL	16:55:26	Abbey Wood	Paddington
CRL	16:57:54	Shenfield	Paddington
CRL	16:59:55	Abbey Wood	Ealing Broadway
CRL	17:01:36	Shenfield	Paddington
CRL	17:03:39	Shenfield	Maidenhead
CRL	17:05:56	Abbey Wood	Heathrow
CRL	17:07:55	Shenfield	Paddington
CRL	17:09:38	Abbey Wood	West Drayton
CRL	17:11:47	Shenfield	Ealing Broadway
CRL	17:13:47	Shenfield	Paddington
CRL	17:15:43	Abbey Wood	Paddington
CRL	17:17:40	Shenfield	Heathrow
CRL	17:19:39	Abbey Wood	Maidenhead
CRL	17:21:31	Shenfield	Paddington
CRL	17:23:49	Shenfield	West Drayton
CRL	17:25:40	Abbey Wood	Paddington
CRL	17:27:23	Shenfield	Ealing Broadway
CRL	17:29:45	Abbey Wood	Paddington
CRL	17:31:49	Shenfield	Paddington
CRL	17:33:31	Shenfield	Maidenhead
CRL	17:35:17	Abbey Wood	Heathrow
CRL	17:37:33	Shenfield	Paddington
CRL	17:39:22	Abbey Wood	West Drayton
CRL	17:41:38	Shenfield	Ealing Broadway
CRL	17:43:53	Shenfield	Paddington
CRL	17:45:17	Abbey Wood	Paddington
CRL	17:47:36	Shenfield	Heathrow
CRL	17:50:04	Abbey Wood	Maidenhead
CRL	17:51:56	Shenfield	Paddington
CRL	17:54:14	Shenfield	West Drayton
CRL	17:56:00	Abbey Wood	Paddington
CRL	17:57:53	Shenfield	Paddington
CRL	17:59:46	Abbey Wood	Ealing Broadway
CRL	18:01:20	Shenfield	Paddington
CRL	18:03:41	Shenfield	Maidenhead
CRL	18:05:19	Abbey Wood	Heathrow
CRL	18:07:52	Shenfield	Paddington
CRL	18:09:33	Abbey Wood	West Drayton
CRL	18:11:31	Shenfield	Ealing Broadway
CRL	18:13:17	Shenfield	Paddington
CRL	18:15:54	Abbey Wood	Paddington
CRL	18:17:52	Shenfield	Heathrow
CRL	18:19:59	Abbey Wood	Maidenhead
CRL	18:21:19	Shenfield	Paddington
CRL	18:23:39	Shenfield	West Drayton
CRL	18:25:19	Abbey Wood	Paddington
CRL	18:27:28	Shenfield	Ealing Broadway
CRL	18:29:17	Abbey Wood	Paddington
CRL	18:31:18	Shenfield	Paddington
CRL	18:33:22	Shenfield	Maidenhead
CRL	18:35:16	Abbey Wood	Heathrow
CRL	18:37:42	Shenfield	Paddington
CRL	18:39:28	Abbey Wood	West Drayton
CRL	18:41:36	Shenfield	Ealing Broadway
CRL	18:43:47	Shenfield	Paddington
CRL	18:45:22	Abbey Wood	Paddington
CRL	18:47:58	Shenfield	Heathrow
CRL	18:49:31	Abbey Wood	Maidenhead
CRL	18:51:57	Shenfield	Paddington
CRL	18:53:27	Shenfield	West Drayton
CRL	18:55:59	Abbey Wood	Paddington
CRL	18:57:52	Shenfield	Paddington
CRL	18:59:25	Abbey Wood	Ealing Broadway

BOND STREET

CRL EB Platform - PM Peak - 2026+28% - 30 TPH

Descriptive Stats	
Peak Period	PM Peak
Future Year	2026+28%
Trains Per Hour	30

07:00 to 10:00		
	\$N\$10:\$N\$99	
CRL	90	100.00%
		0.00%
		0.00%
<b>Total</b>	<b>90</b>	

07:00 to 08:00		
	\$N\$10:\$N\$39	
CRL	30	100.00%
		0.00%
		0.00%
<b>Total</b>	<b>30</b>	

08:00 to 09:00		
	\$N\$40:\$N\$69	
CRL	30	100.00%
		0.00%
		0.00%
<b>Total</b>	<b>30</b>	

09:00 to 10:00		
	\$N\$70:\$N\$99	
CRL	30	100.00%
		0.00%
		0.00%
<b>Total</b>	<b>30</b>	

		Origin	Destination
CRL	16:00:29	Paddington	Shenfield
CRL	16:02:15	Maidenhead	Shenfield
CRL	16:04:54	Heathrow	Abbey Wood
CRL	16:06:17	Paddington	Shenfield
CRL	16:08:35	West Drayton	Abbey Wood
CRL	16:10:27	Ealing Broadway	Shenfield
CRL	16:12:19	Paddington	Shenfield
CRL	16:14:27	Paddington	Abbey Wood
CRL	16:16:17	Heathrow	Shenfield
CRL	16:18:48	Maidenhead	Abbey Wood
CRL	16:20:54	Paddington	Shenfield
CRL	16:22:27	West Drayton	Shenfield
CRL	16:24:17	Paddington	Abbey Wood
CRL	16:26:28	Ealing Broadway	Shenfield
CRL	16:28:18	Paddington	Abbey Wood
CRL	16:30:17	Paddington	Shenfield
CRL	16:32:30	Maidenhead	Shenfield
CRL	16:34:29	Heathrow	Abbey Wood
CRL	16:36:21	Paddington	Shenfield
CRL	16:39:00	West Drayton	Abbey Wood
CRL	16:41:04	Ealing Broadway	Shenfield
CRL	16:42:41	Paddington	Shenfield
CRL	16:44:48	Paddington	Abbey Wood
CRL	16:46:39	Heathrow	Shenfield
CRL	16:48:20	Maidenhead	Abbey Wood
CRL	16:50:40	Paddington	Shenfield
CRL	16:52:20	West Drayton	Shenfield
CRL	16:55:04	Paddington	Abbey Wood
CRL	16:56:38	Paddington	Shenfield
CRL	16:58:15	Ealing Broadway	Abbey Wood
CRL	17:00:25	Paddington	Shenfield
CRL	17:02:43	Maidenhead	Shenfield
CRL	17:04:28	Heathrow	Abbey Wood
CRL	17:06:22	Paddington	Shenfield
CRL	17:08:19	West Drayton	Abbey Wood
CRL	17:10:21	Ealing Broadway	Shenfield
CRL	17:12:21	Paddington	Shenfield
CRL	17:14:20	Paddington	Abbey Wood
CRL	17:17:05	Heathrow	Shenfield
CRL	17:18:17	Maidenhead	Abbey Wood
CRL	17:20:54	Paddington	Shenfield
CRL	17:22:40	West Drayton	Shenfield
CRL	17:24:40	Paddington	Abbey Wood
CRL	17:26:20	Ealing Broadway	Shenfield
CRL	17:28:42	Paddington	Abbey Wood
CRL	17:30:30	Paddington	Shenfield
CRL	17:33:00	Maidenhead	Shenfield
CRL	17:34:17	Heathrow	Abbey Wood
CRL	17:36:58	Paddington	Shenfield
CRL	17:38:24	West Drayton	Abbey Wood
CRL	17:40:39	Ealing Broadway	Shenfield
CRL	17:42:48	Paddington	Shenfield
CRL	17:44:55	Paddington	Abbey Wood
CRL	17:46:29	Heathrow	Shenfield
CRL	17:48:52	Maidenhead	Abbey Wood
CRL	17:50:15	Paddington	Shenfield
CRL	17:52:28	West Drayton	Shenfield
CRL	17:54:27	Paddington	Abbey Wood
CRL	17:56:39	Paddington	Shenfield
CRL	17:58:53	Ealing Broadway	Abbey Wood
CRL	18:00:29	Paddington	Shenfield
CRL	18:02:33	Maidenhead	Shenfield
CRL	18:04:23	Heathrow	Abbey Wood
CRL	18:06:17	Paddington	Shenfield
CRL	18:08:19	West Drayton	Abbey Wood
CRL	18:10:39	Ealing Broadway	Shenfield
CRL	18:12:16	Paddington	Shenfield
CRL	18:14:27	Paddington	Abbey Wood
CRL	18:16:57	Heathrow	Shenfield
CRL	18:18:42	Maidenhead	Abbey Wood
CRL	18:20:41	Paddington	Shenfield
CRL	18:23:02	West Drayton	Shenfield
CRL	18:24:16	Paddington	Abbey Wood
CRL	18:26:30	Ealing Broadway	Shenfield
CRL	18:29:02	Paddington	Abbey Wood
CRL	18:31:01	Paddington	Shenfield
CRL	18:32:31	Maidenhead	Shenfield
CRL	18:34:21	Heathrow	Abbey Wood
CRL	18:36:21	Paddington	Shenfield
CRL	18:38:18	West Drayton	Abbey Wood
CRL	18:41:03	Ealing Broadway	Shenfield
CRL	18:42:54	Paddington	Shenfield
CRL	18:44:58	Paddington	Abbey Wood
CRL	18:46:31	Heathrow	Shenfield
CRL	18:48:22	Maidenhead	Abbey Wood
CRL	18:51:03	Paddington	Shenfield
CRL	18:52:19	West Drayton	Shenfield
CRL	18:54:39	Paddington	Abbey Wood
CRL	18:56:26	Paddington	Shenfield
CRL	18:58:35	Ealing Broadway	Abbey Wood

RODS2008

	0700-0715	0715-0730	0730-0745	0745-0800	0800-0815	0815-0830	0830-0845	0845-0900	0900-0915	0915-0930	0930-0945	0945-1000	total
BOND STREET T H	68	86	108	131	160	188	207	210	210	211	217	220	2016
BOND STREET EXITS	0	0	0	0	0	0	0	0	0	0	0	0	0
BOND STREET CENTRAL WB	205	286	384	476	555	665	790	861	809	691	574	492	6788
BOND STREET CENTRAL EB	186	249	319	389	465	552	618	617	547	457	380	321	5100
BOND STREET JUBILEE NB	309	438	600	742	858	1001	1154	1223	1137	956	781	658	9857
BOND STREET JUBILEE SB	285	400	527	651	791	944	1054	1047	927	767	626	515	8534

BOND STREET TH	3.37%	4.27%	5.36%	6.50%	7.94%	9.33%	10.27%	10.42%	10.42%	10.47%	10.76%	10.91%
BOND STREET CENTRAL WB	3.02%	4.21%	5.66%	7.01%	8.18%	9.80%	11.64%	12.68%	11.92%	10.18%	8.46%	7.25%
BOND STREET CENTRAL EB	3.65%	4.88%	6.25%	7.63%	9.12%	10.82%	12.12%	12.10%	10.73%	8.96%	7.45%	6.29%
BOND STREET JUBILEE NB	3.13%	4.44%	6.09%	7.53%	8.70%	10.16%	11.71%	12.41%	11.53%	9.70%	7.92%	6.68%
BOND STREET JUBILEE SB	3.34%	4.69%	6.18%	7.63%	9.27%	11.06%	12.35%	12.27%	10.86%	8.99%	7.34%	6.03%

Proxy Required.....

CRL WB	3.02%	4.21%	5.66%	7.01%	8.18%	9.80%	11.64%	12.68%	11.92%	10.18%	8.46%	7.25%
CRL EB	3.65%	4.88%	6.25%	7.63%	9.12%	10.82%	12.12%	12.10%	10.73%	8.96%	7.45%	6.29%

Learning Legacy Document



**Appendix D – PM Peak 2026+28% Cover Sheet**

Learning Legacy Document



## Appendix E – AM 2026 Density Maps

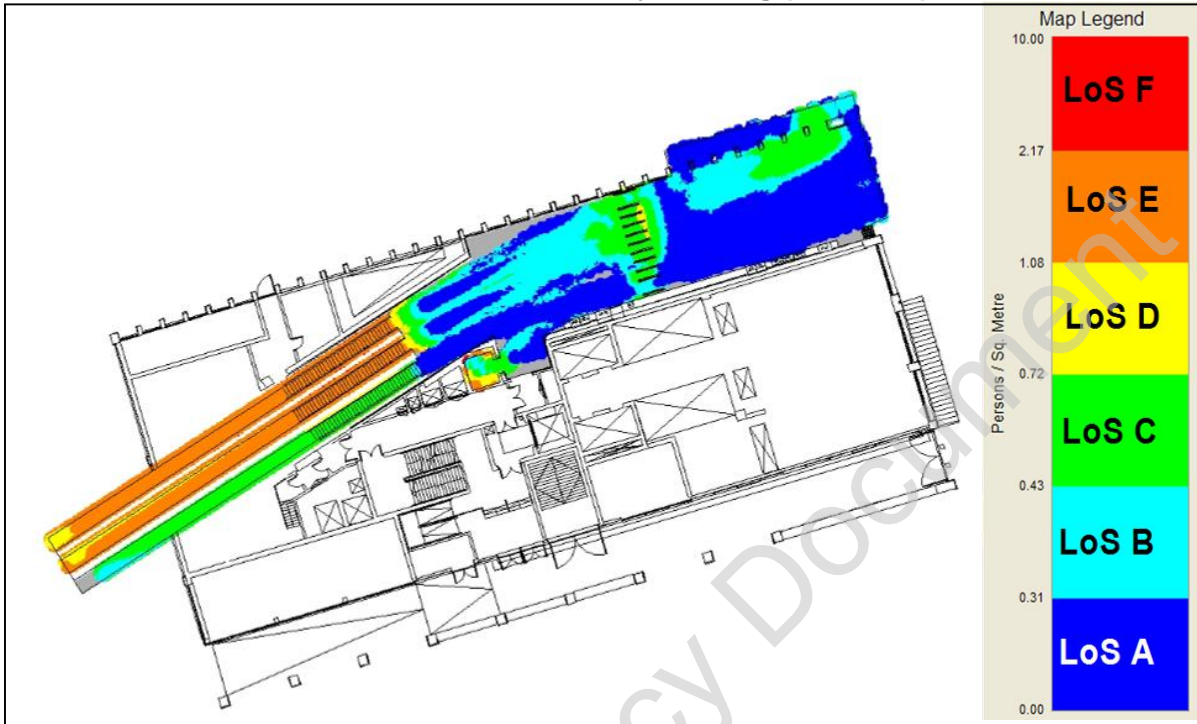
Cumulative Mean Density (CMD) maps provide the average density conditions that occur within the peak 15 minutes these are presented in 15 minute segments for the peak hour (8:30-9:30).

Cumulative High Density Maps (CHD) maps shows how long various areas of a site have registered densities greater than 1.54 passengers/sq.metre (LoS D for queuing). The range of colours represent time, in 1 minute intervals (up to 6 minutes). The map is similar to a 'temperature' map: areas that have experienced high levels of density for a long time appear red; those that have experienced shorter periods of density appear blue.

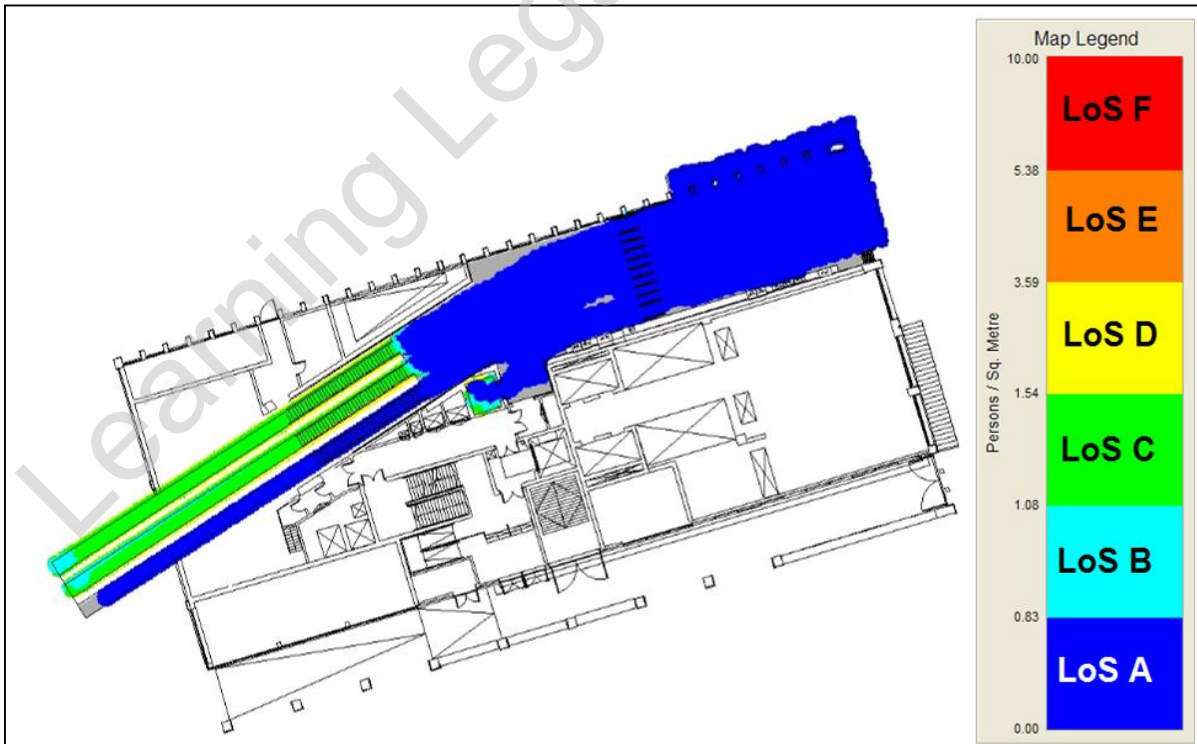
Learning Legacy Document

Hanover Square Ticket Hall

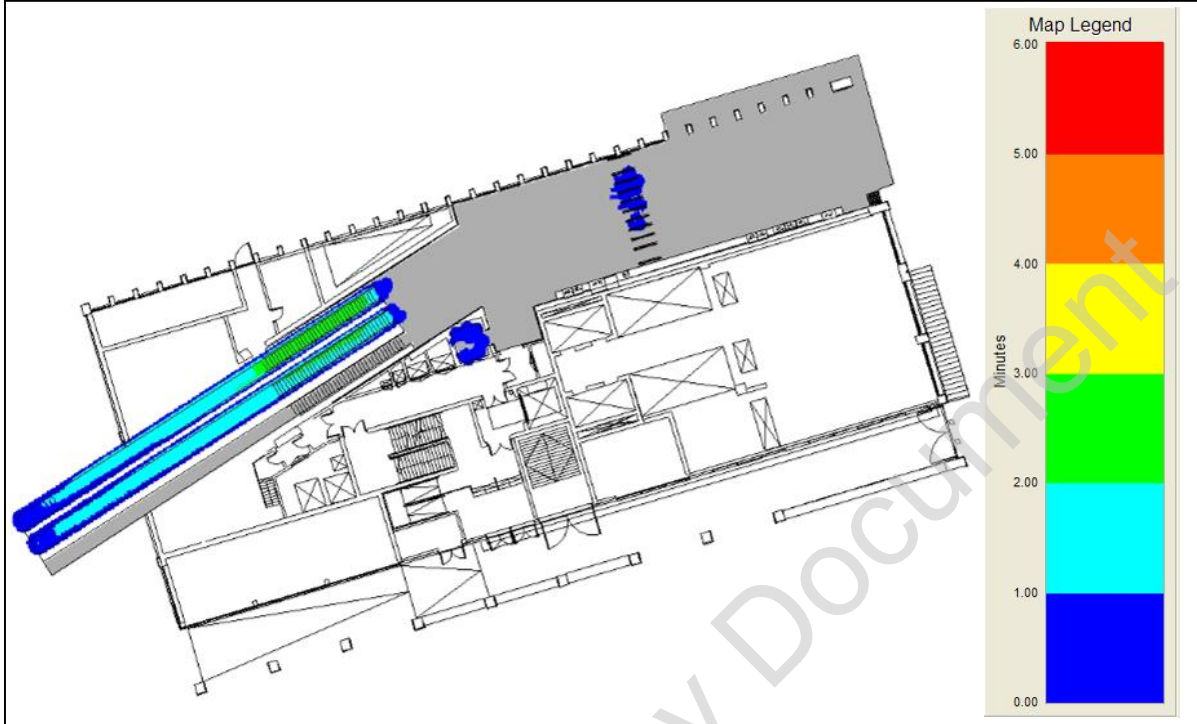
AM Peak 2026 Stage E Design Hanover Square Ticket Hall  
Cumulative Mean Density Walking (8:30-8:45)



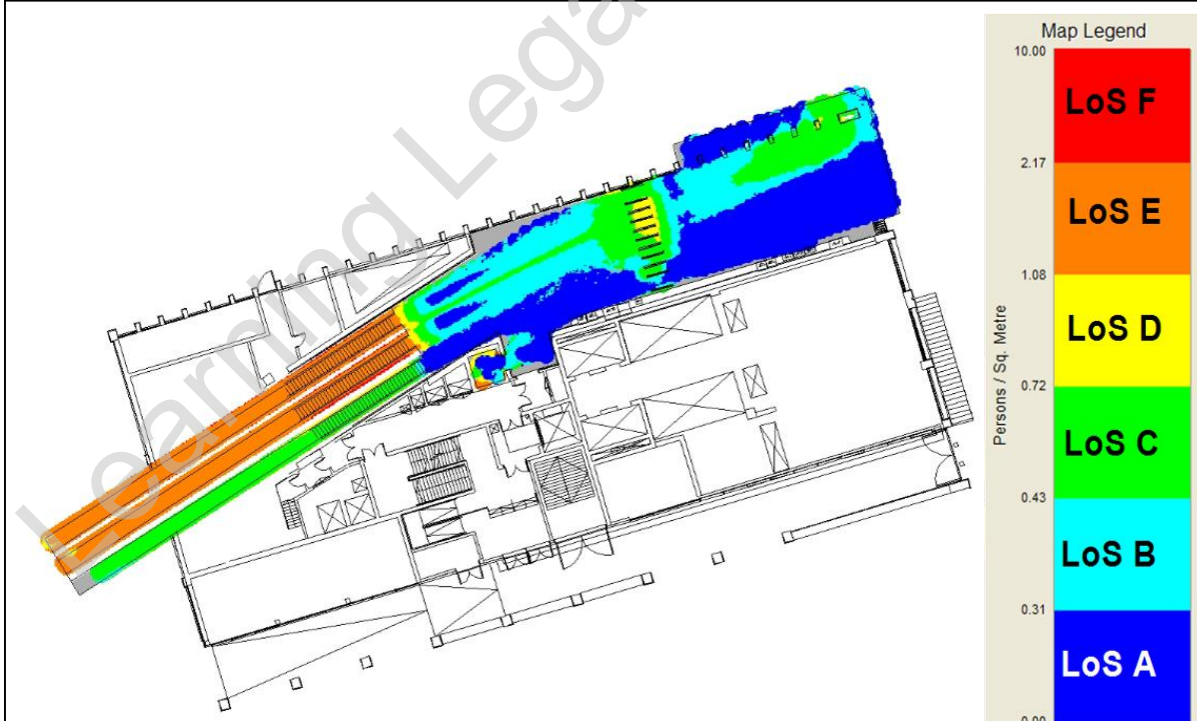
AM Peak 2026 Stage E Design Hanover Square Ticket Hall  
Cumulative Mean Density Queuing (8:30-8:45)



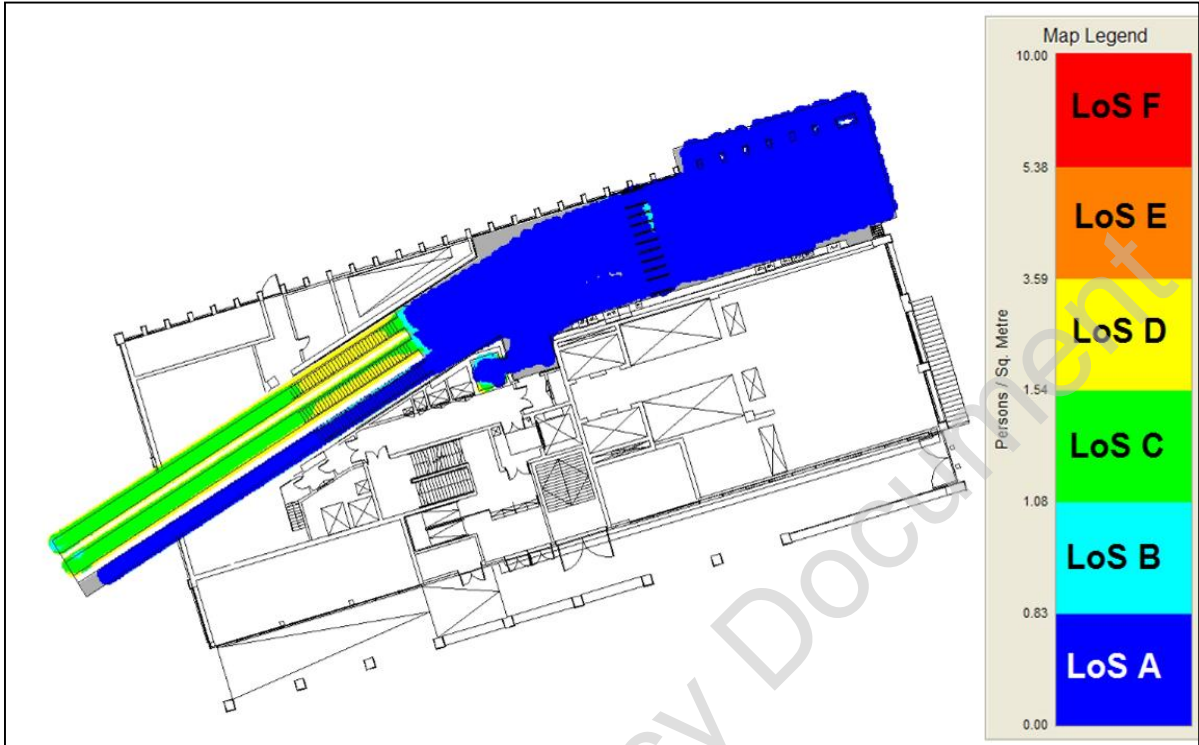
**AM Peak 2026 Stage E Design Hanover Square Ticket Hall  
 Cumulative High Density (8:30-8:45)**



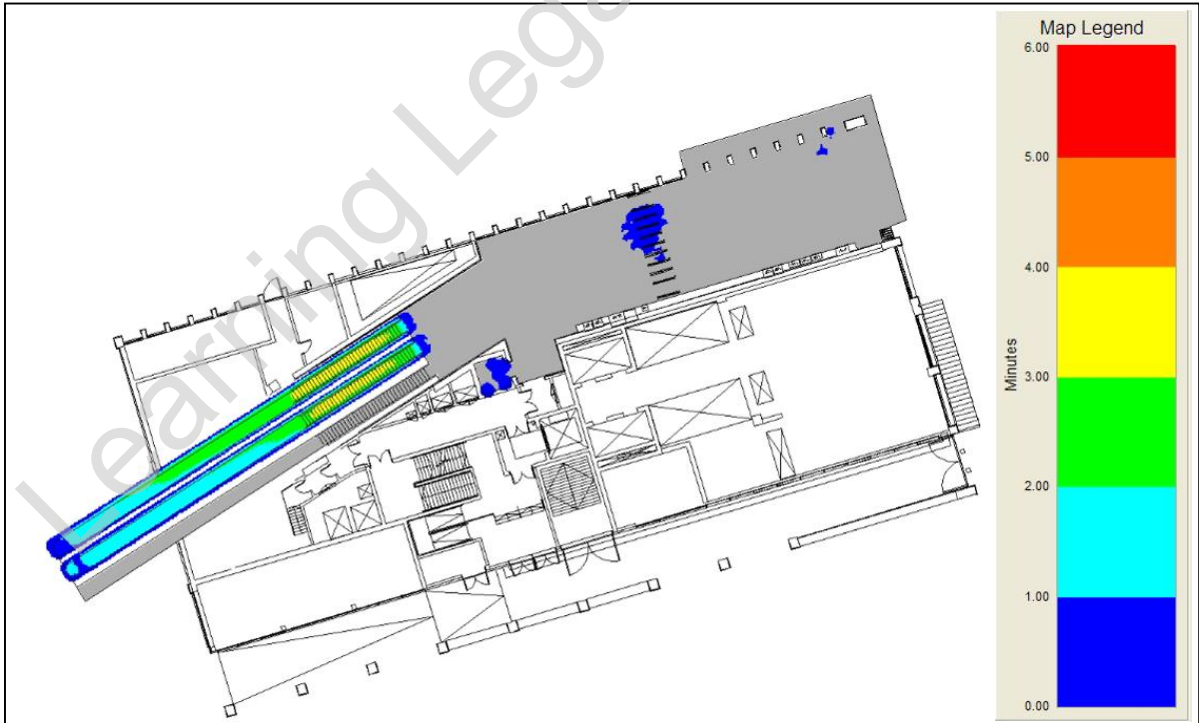
**AM Peak 2026 Stage E Design Hanover Square Ticket Hall  
 Cumulative Mean Density Walking (8:45-9:00)**



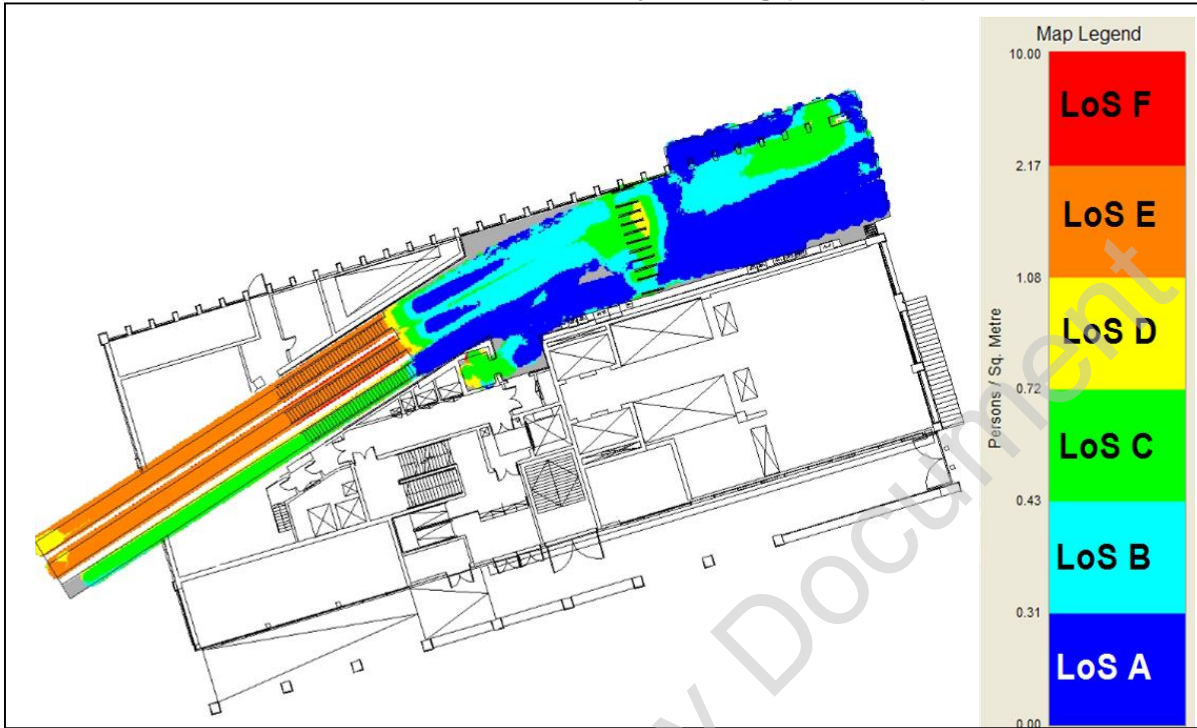
**AM Peak 2026 Stage E Design Hanover Square Ticket Hall  
 Cumulative Mean Density Queuing (8:45-9:00)**



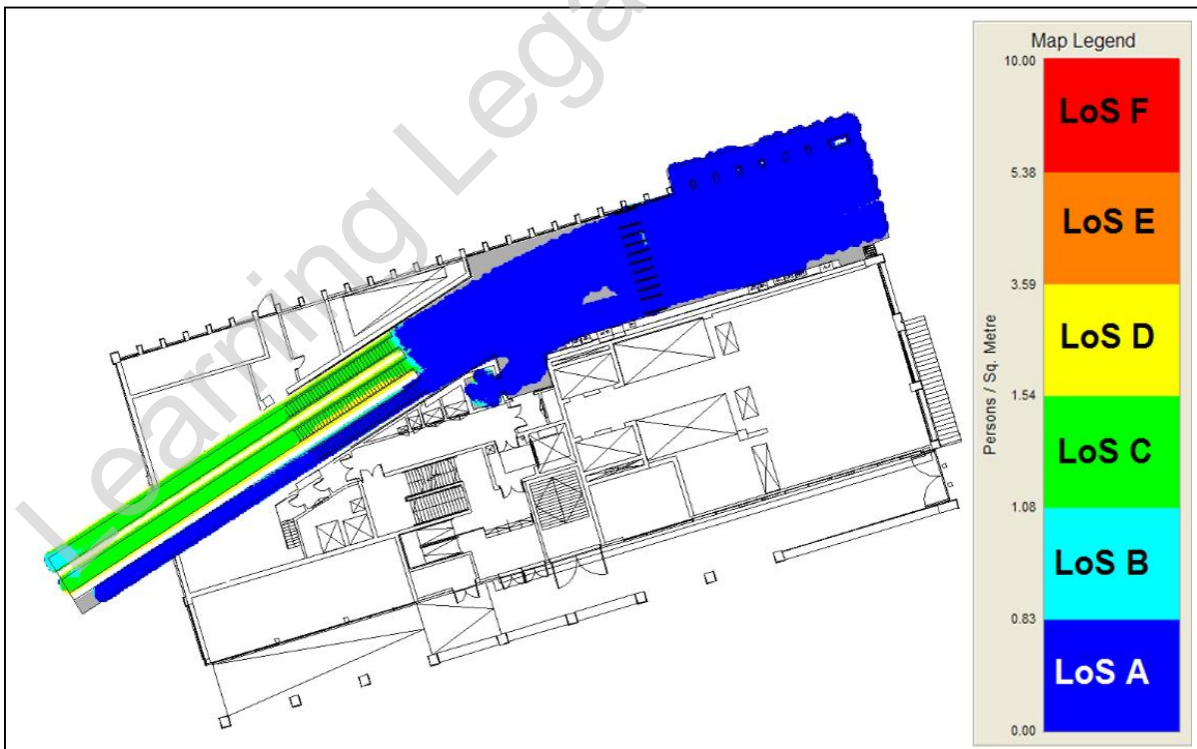
**AM Peak 2026 Stage E Design Hanover Square Ticket Hall  
 Cumulative High Density (8:45-9:00)**



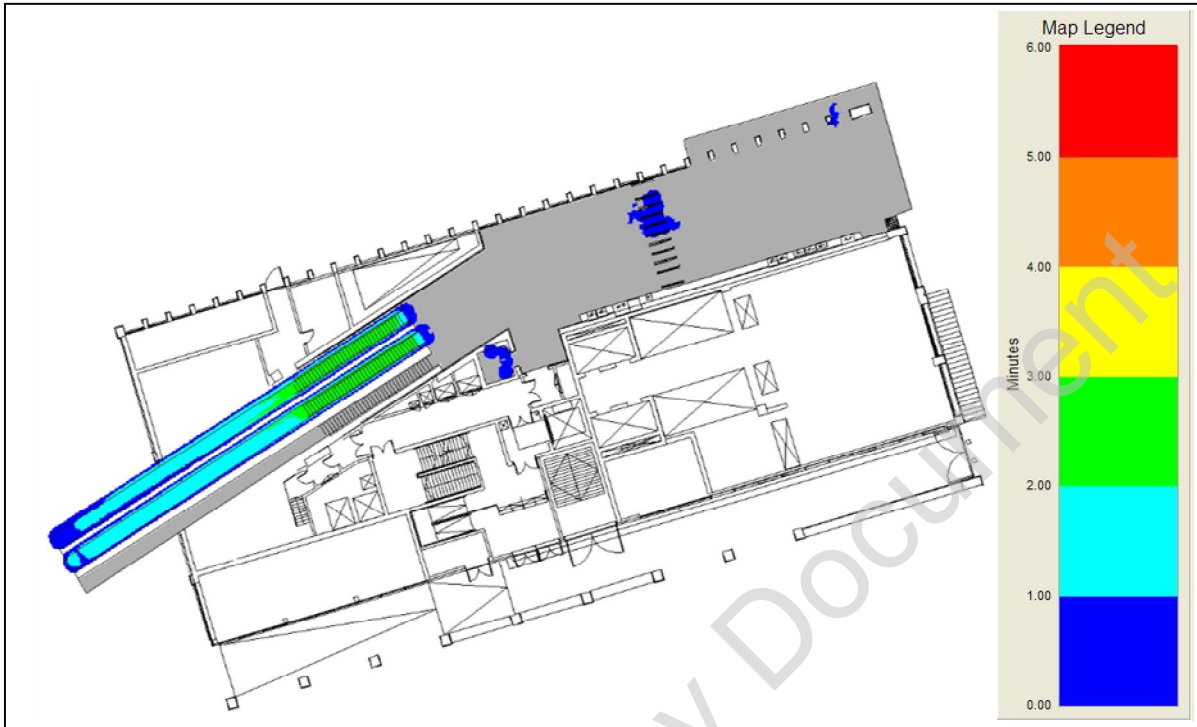
**AM Peak 2026 Stage E Design Hanover Square Ticket Hall  
 Cumulative Mean Density Walking (9:00-9:15)**



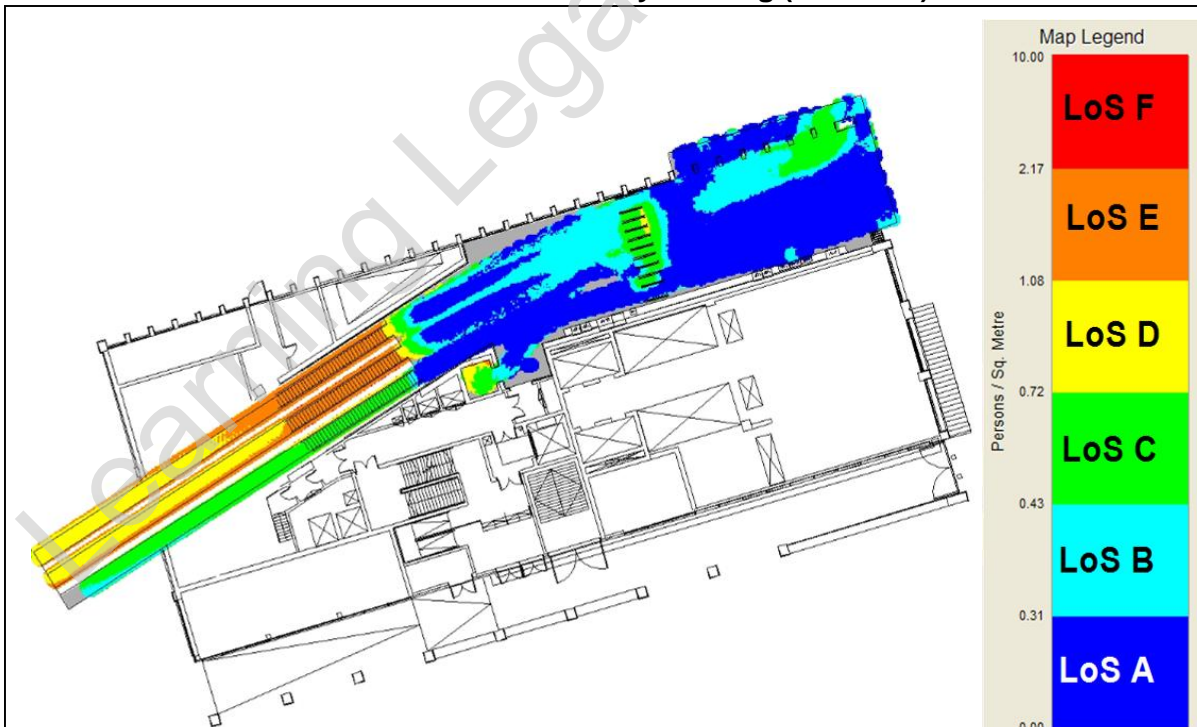
**AM Peak 2026 Stage E Design Hanover Square Ticket Hall  
 Cumulative Mean Density Queuing (9:00-9:15)**



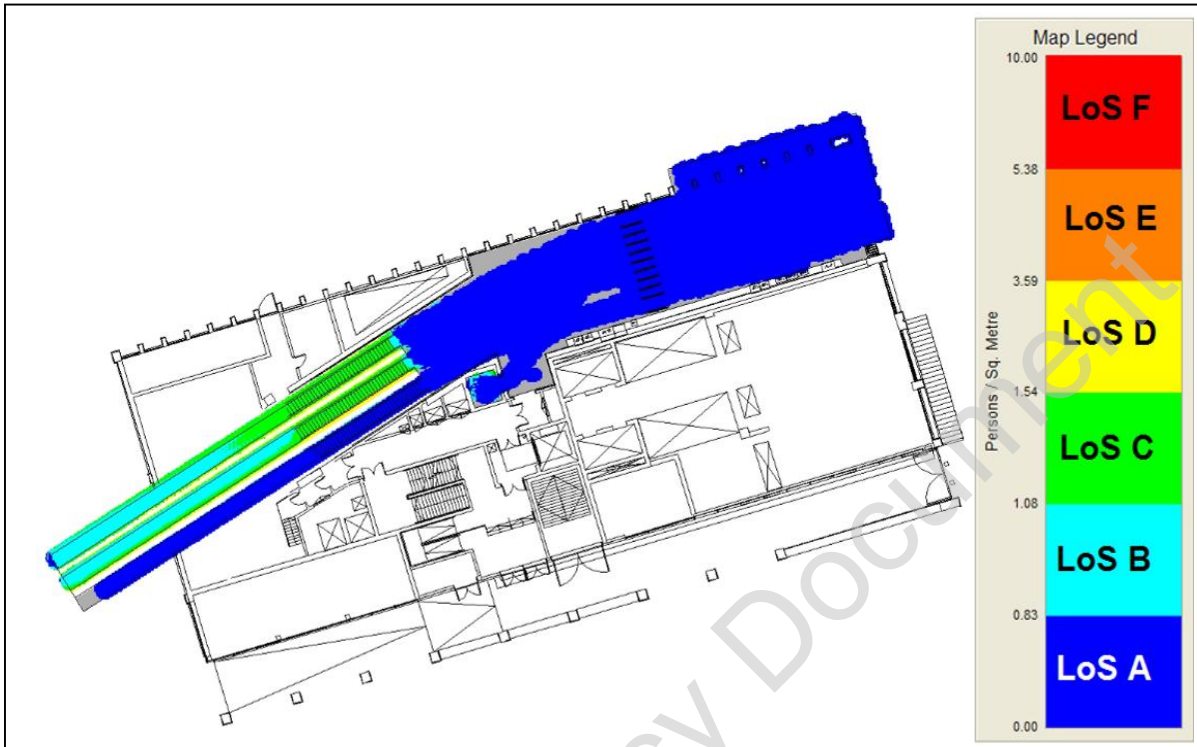
**AM Peak 2026 Stage E Design Hanover Square Ticket Hall  
 Cumulative High Density (9:00-9:15)**



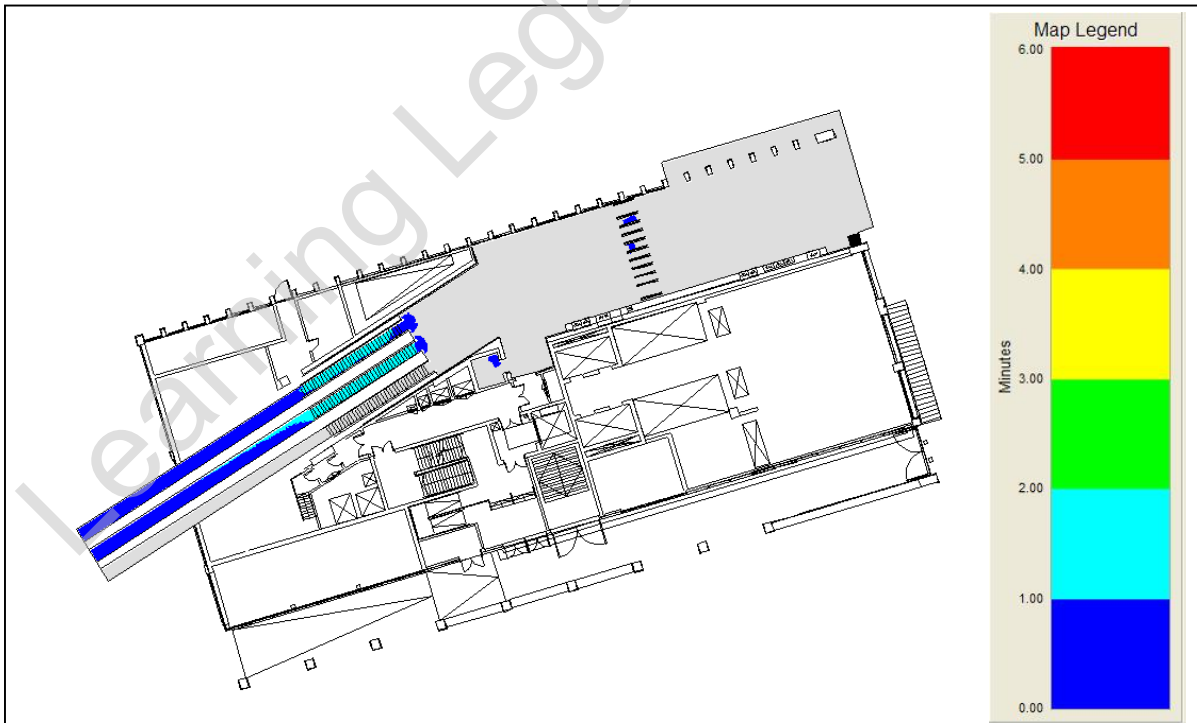
**AM Peak 2026 Stage E Design Hanover Square Ticket Hall  
 Cumulative Mean Density Walking (9:15-9:30)**



**AM Peak 2026 Stage E Design Hanover Square Ticket Hall  
 Cumulative Mean Density Queuing (9:15-9:30)**

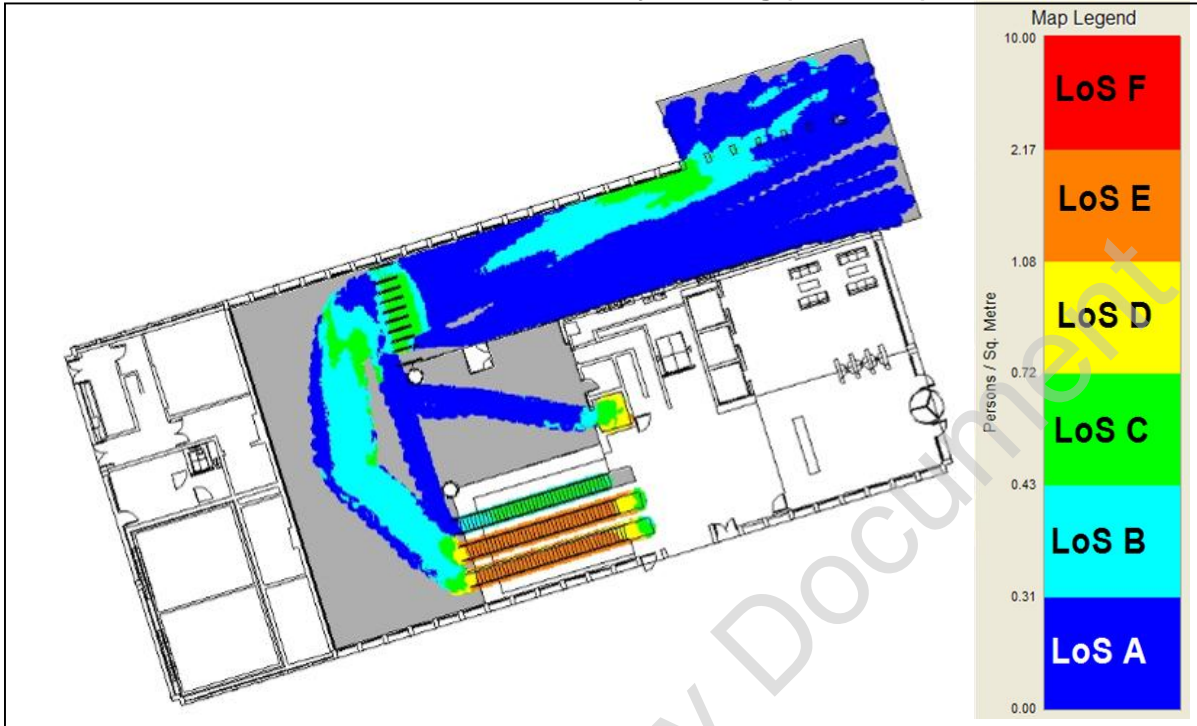


**AM Peak 2026 Stage E Design Hanover Square Ticket Hall  
 Cumulative High (9:15-9:30)**

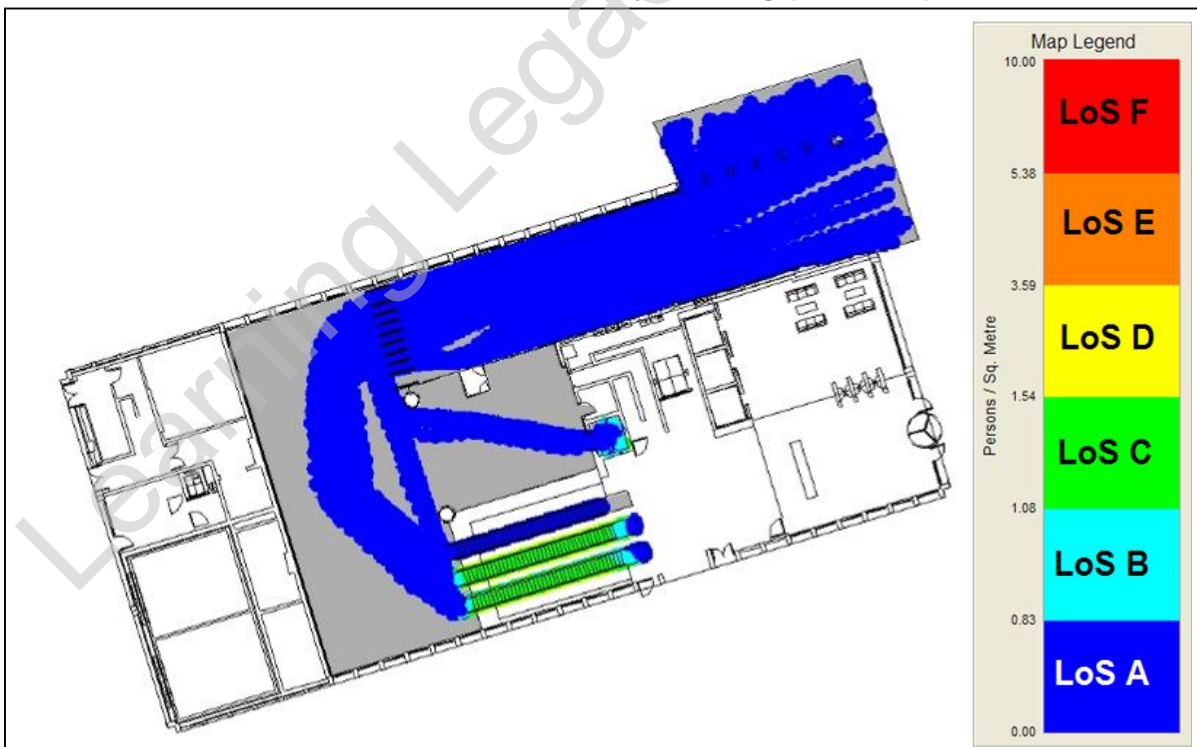


Davies Street Ticket Hall

**AM Peak 2026 Stage E Design Davies Street Ticket Hall  
 Cumulative Mean Density Walking (8:30-8:45)**

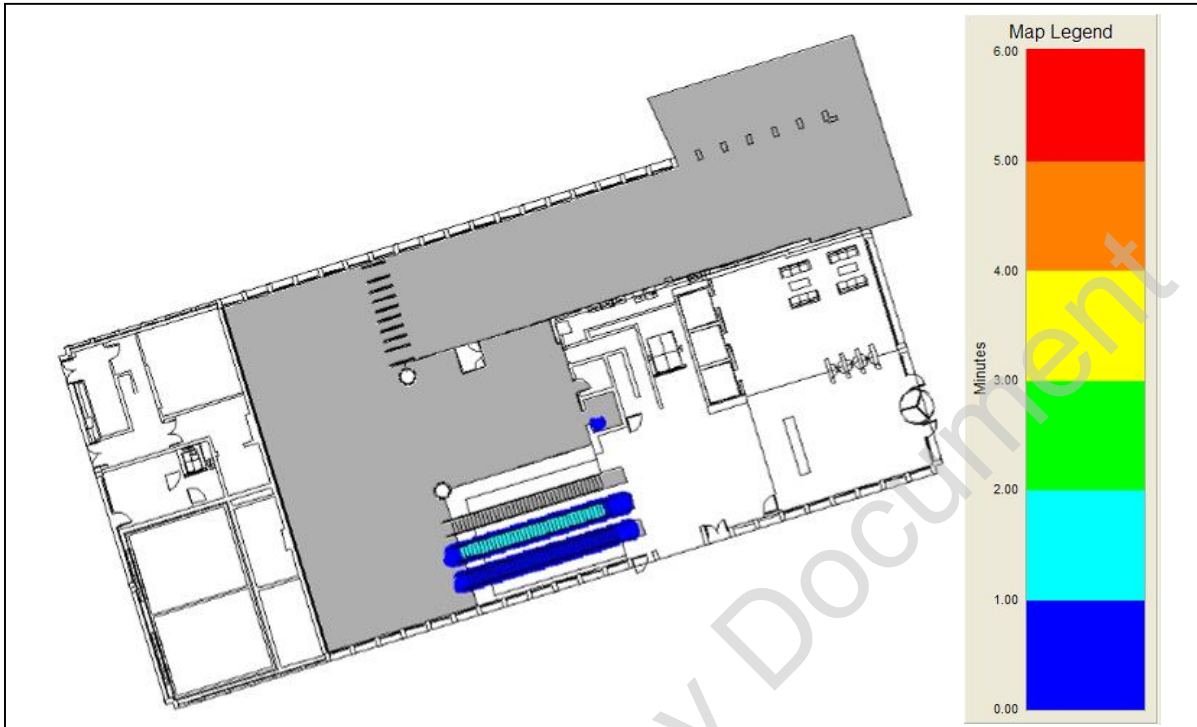


**AM Peak 2026 Stage E Design Davies Street Ticket Hall  
 Cumulative Mean Density Queuing (8:30-8:45)**

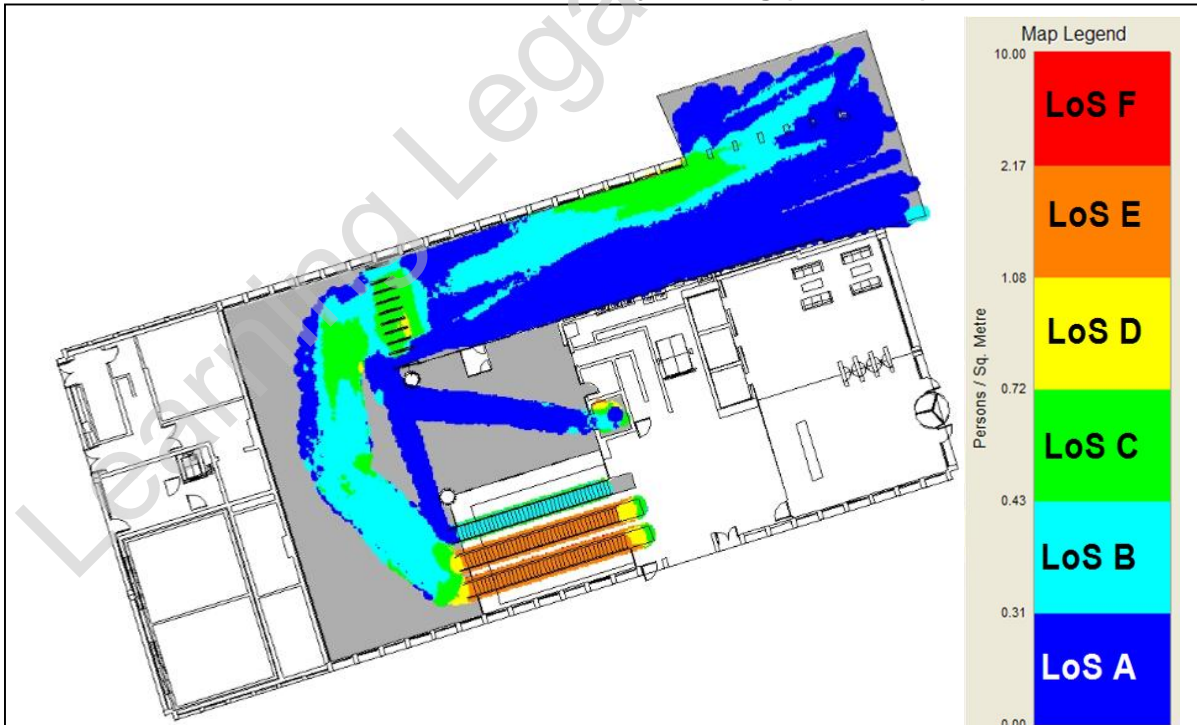




**AM Peak 2026 Stage E Design Davies Street Ticket Hall  
 Cumulative High Density (8:30-8:45)**



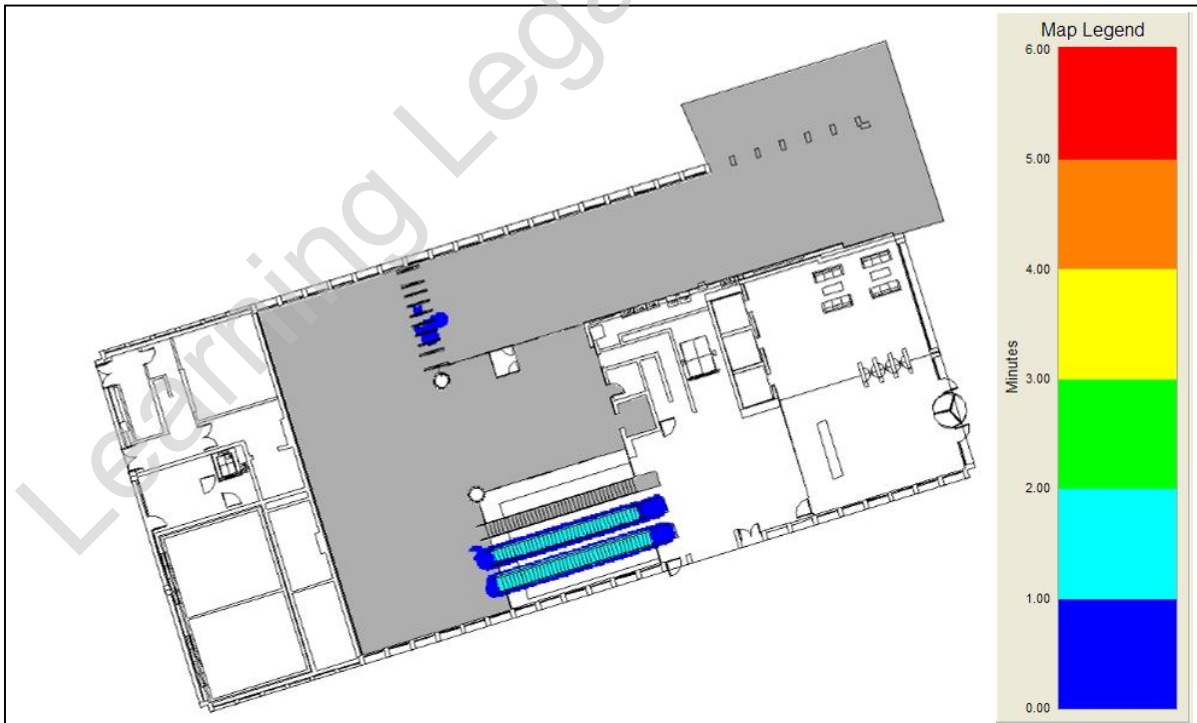
**AM Peak 2026 Stage E Design Davies Street Ticket Hall  
 Cumulative Mean Density Walking (8:45-9:00)**



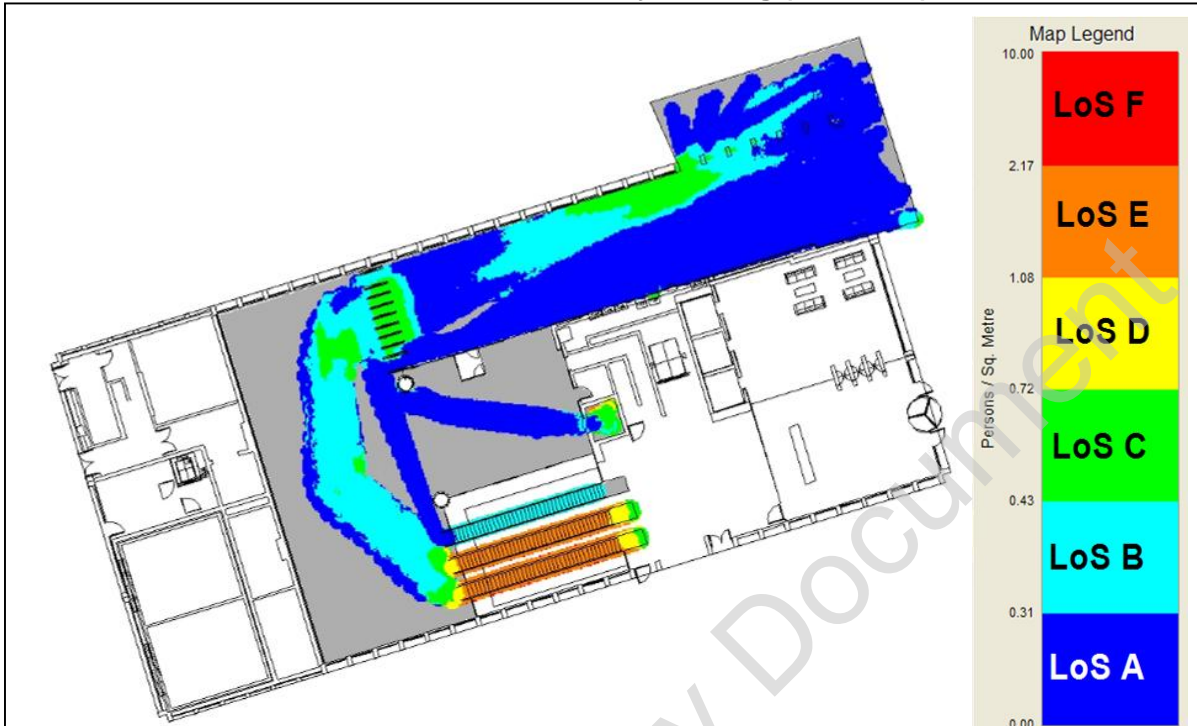
**AM Peak 2026 Stage E Design Davies Street Ticket Hall  
 Cumulative Mean Density Queuing (8:45-9:00)**



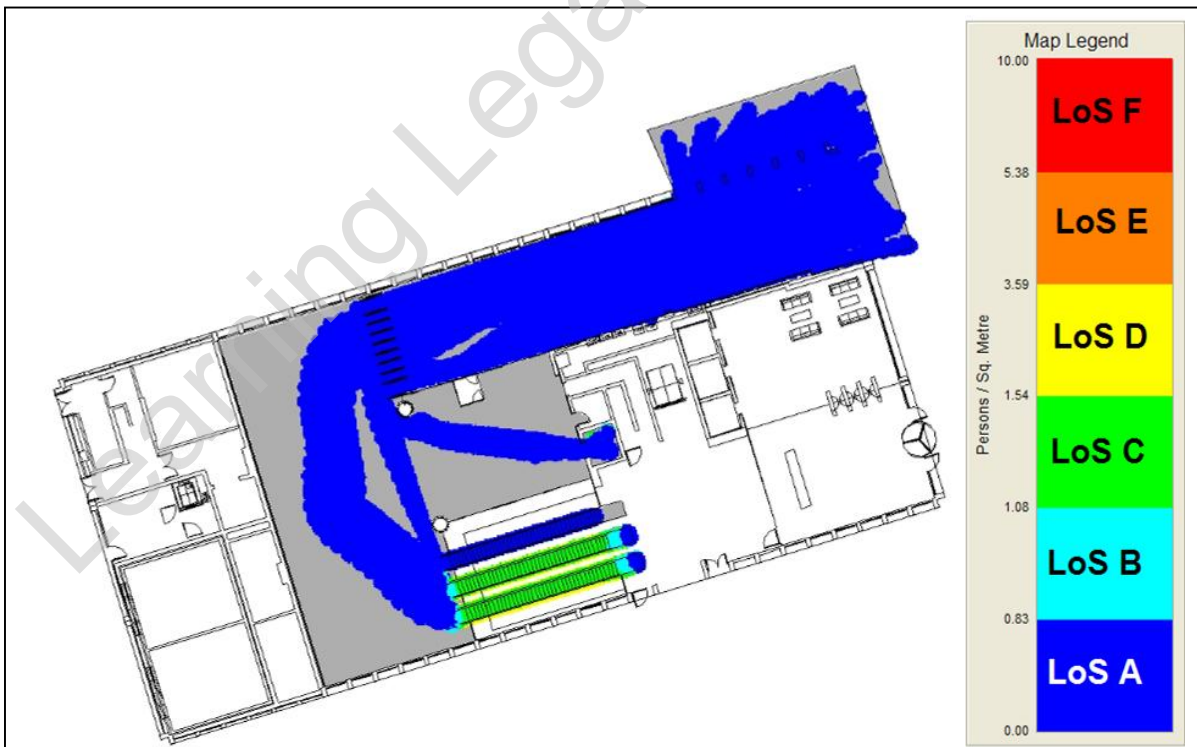
**AM Peak 2026 Stage E Design Davies Street Ticket Hall  
 Cumulative High Density (8:45-9:00)**



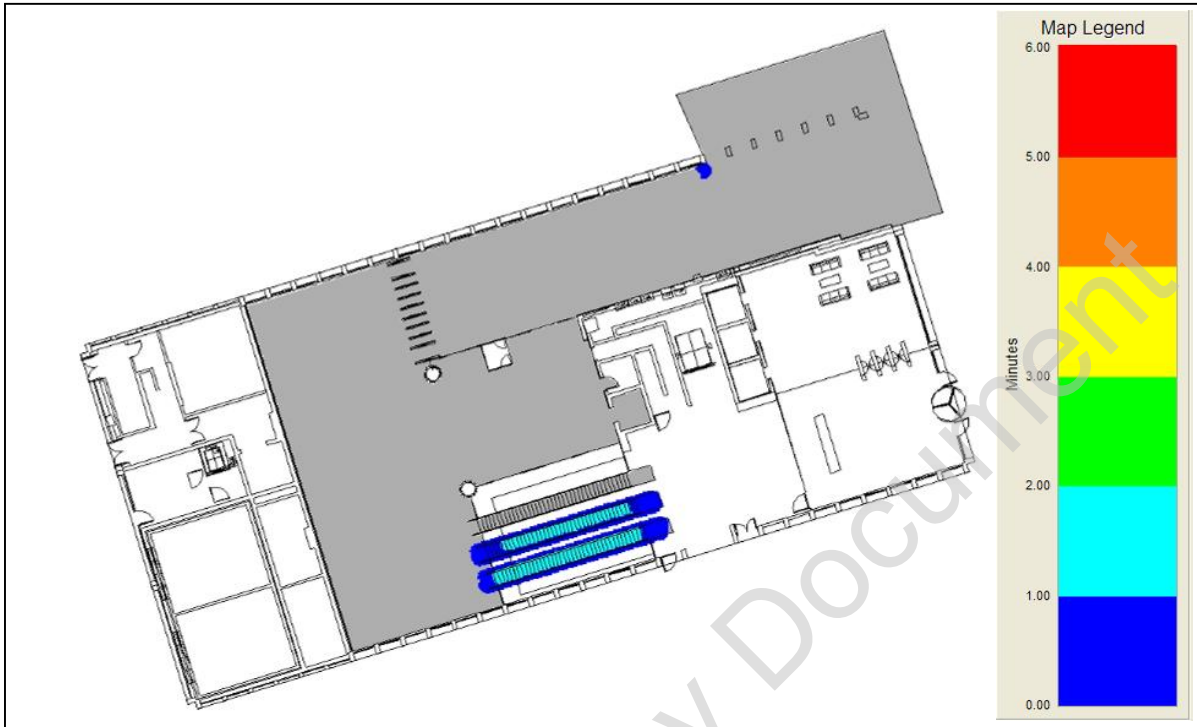
**AM Peak 2026 Stage E Design Davies Street Ticket Hall  
 Cumulative Mean Density Walking (9:00-9:15)**



**AM Peak 2026 Stage E Design Davies Street Ticket Hall  
 Cumulative Mean Density Queuing (9:00-9:15)**



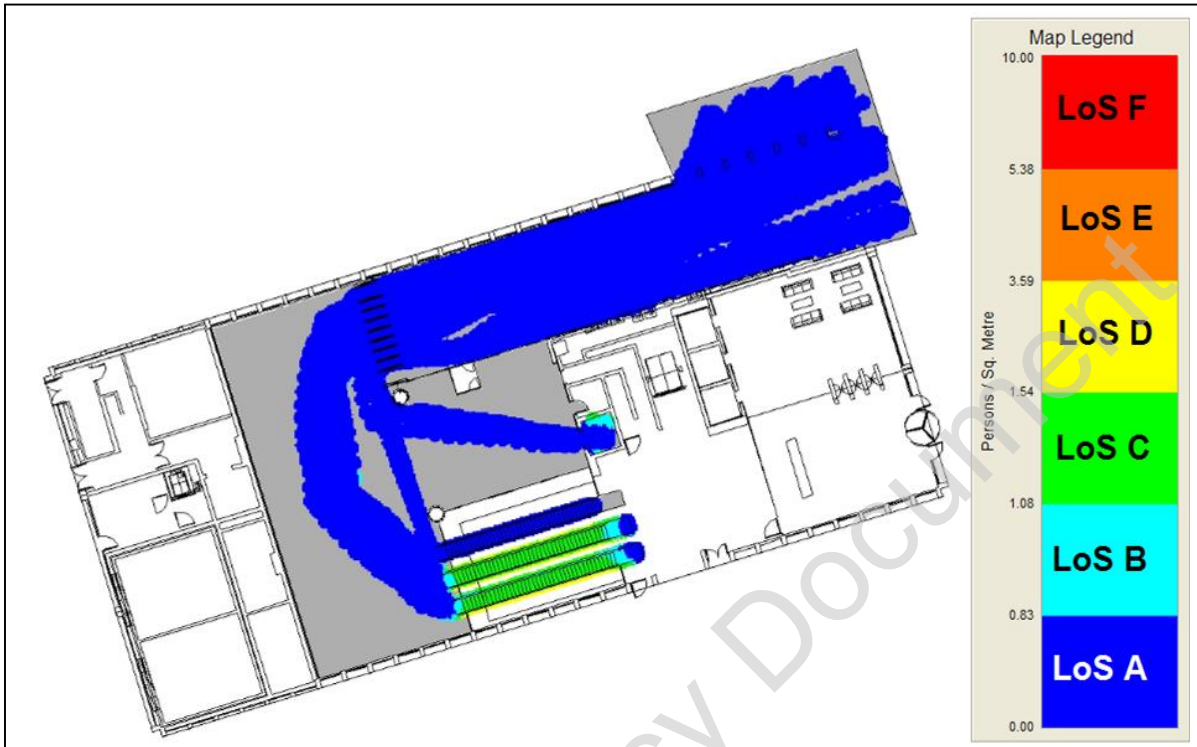
**AM Peak 2026 Stage E Design Davies Street Ticket Hall  
 Cumulative High Density (9:00-9:15)**



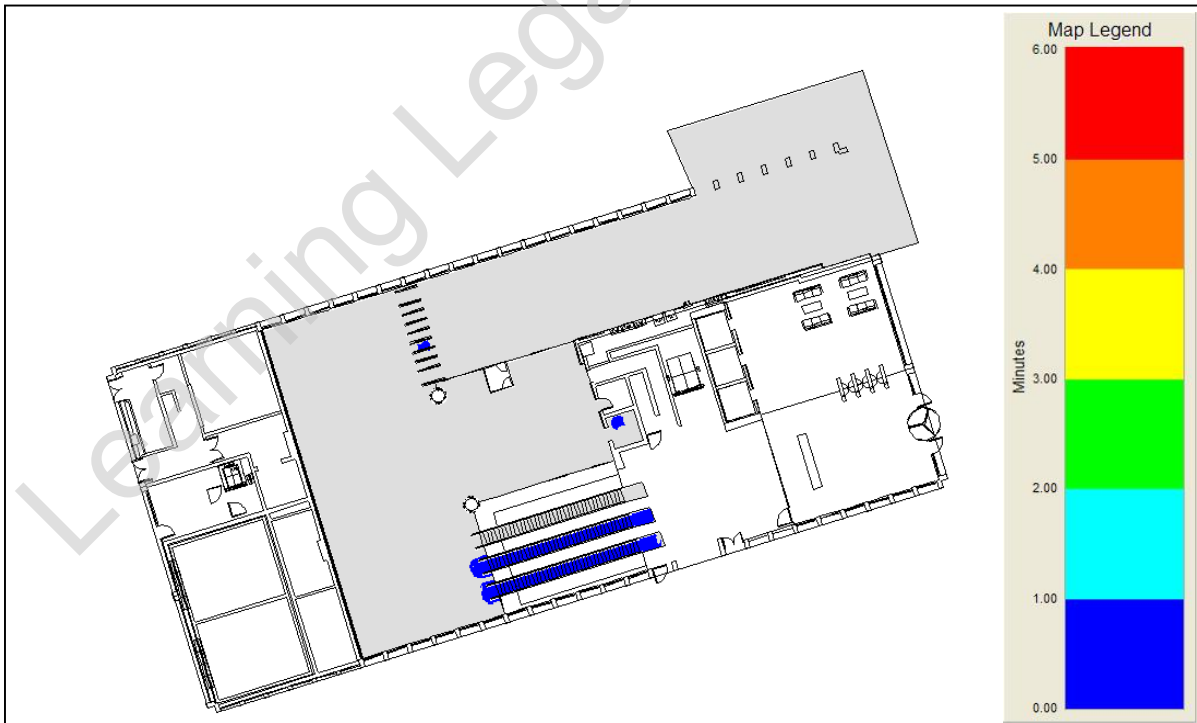
**AM Peak 2026 Stage E Design Davies Street Ticket Hall  
 Cumulative Mean Density Walking (9:15-9:30)**



**AM Peak 2026 Stage E Design Davies Street Ticket Hall  
 Cumulative Mean Density Queuing (9:15-9:30)**

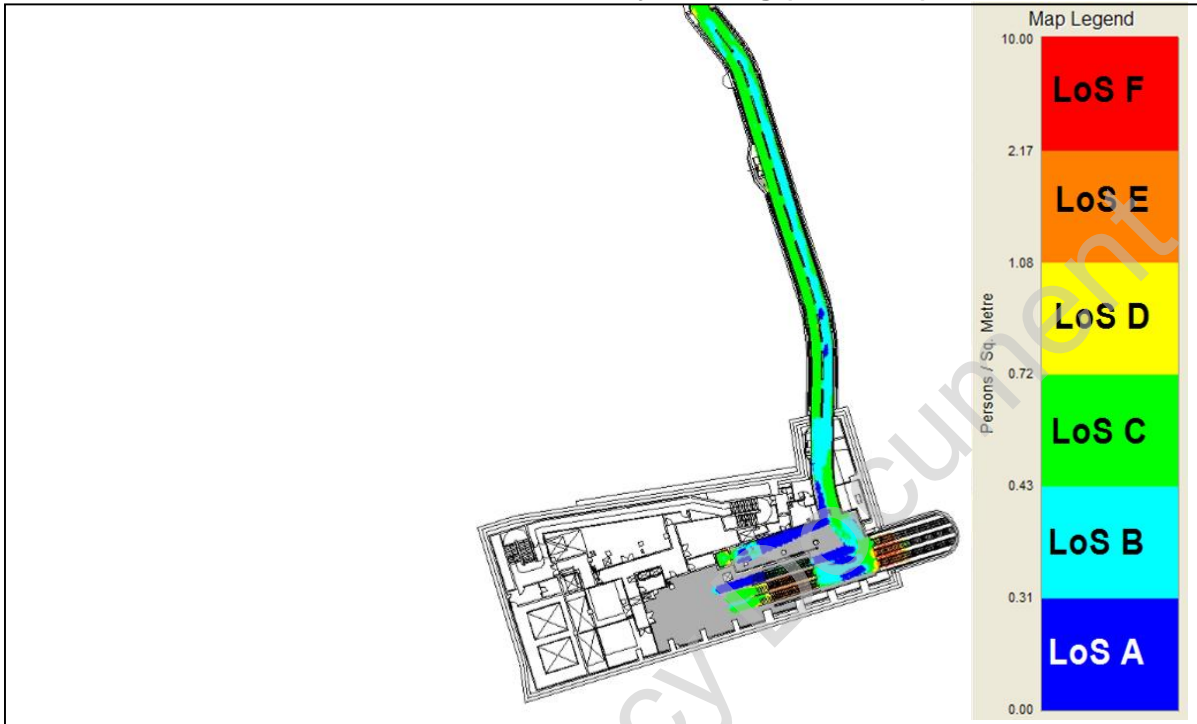


**AM Peak 2026 Stage E Design Davies Street Ticket Hall  
 Cumulative High (9:15-9:30)**

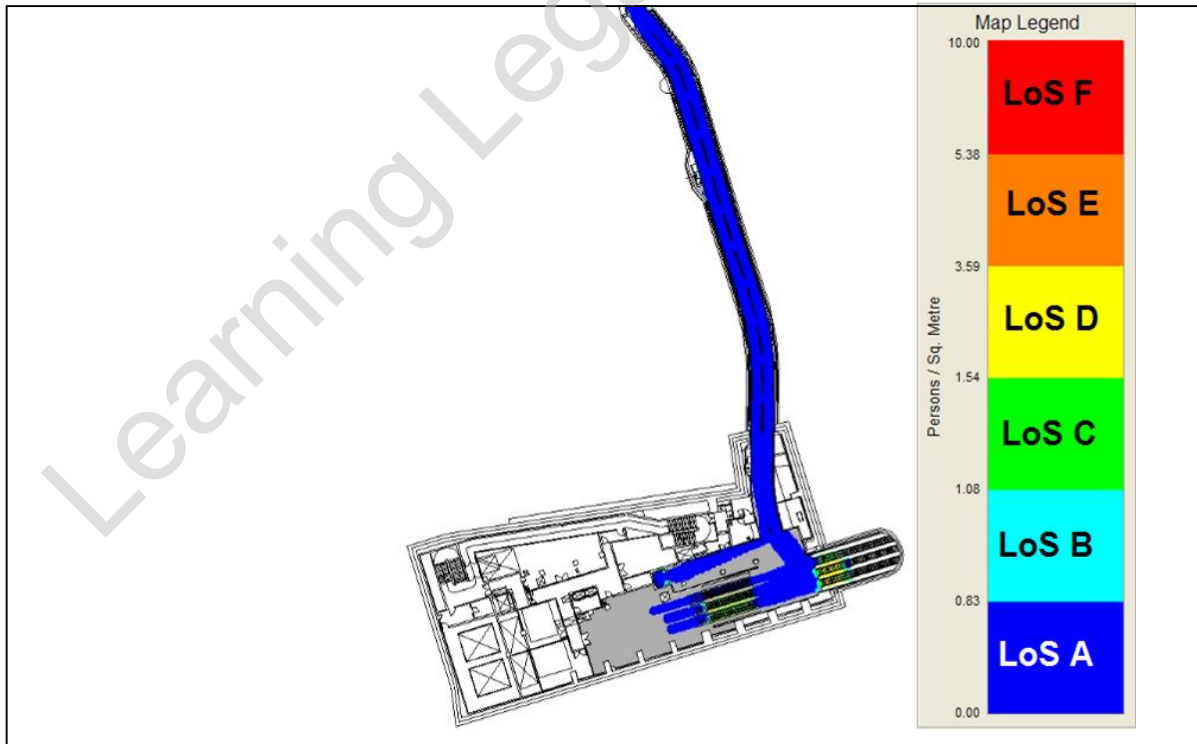


Intermediate Level

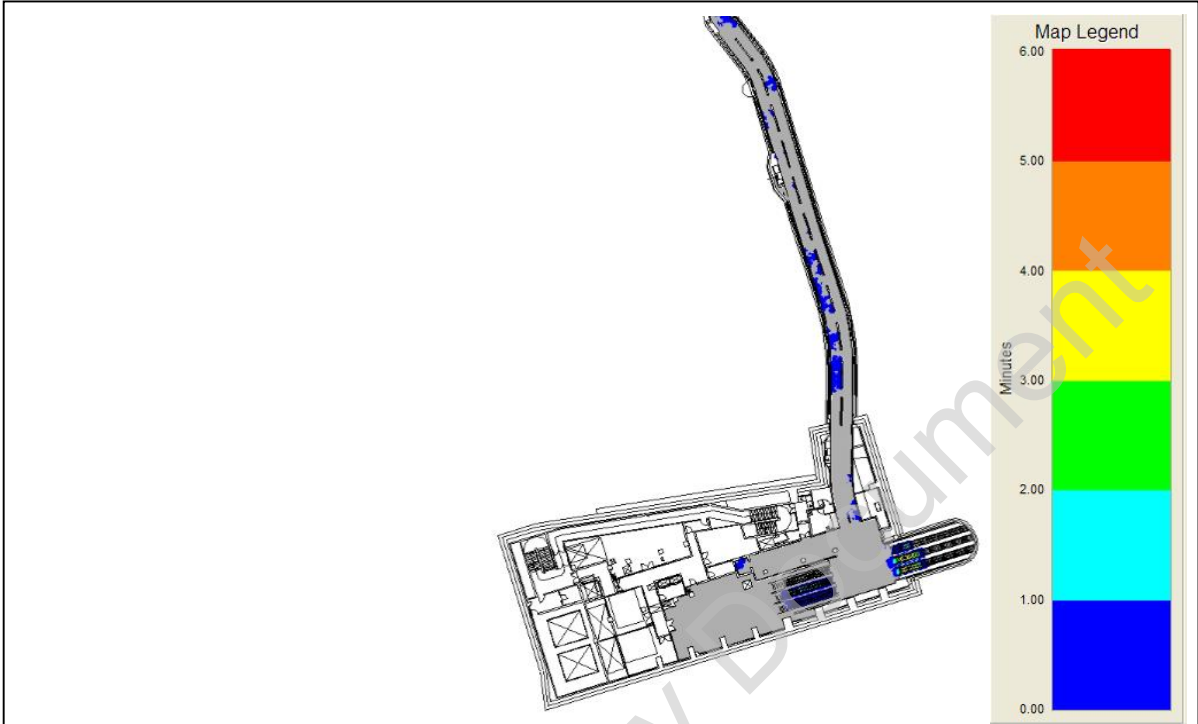
AM Peak 2026 Stage E Design Intermediate Level  
 Cumulative Mean Density Walking (8:30-8:45)



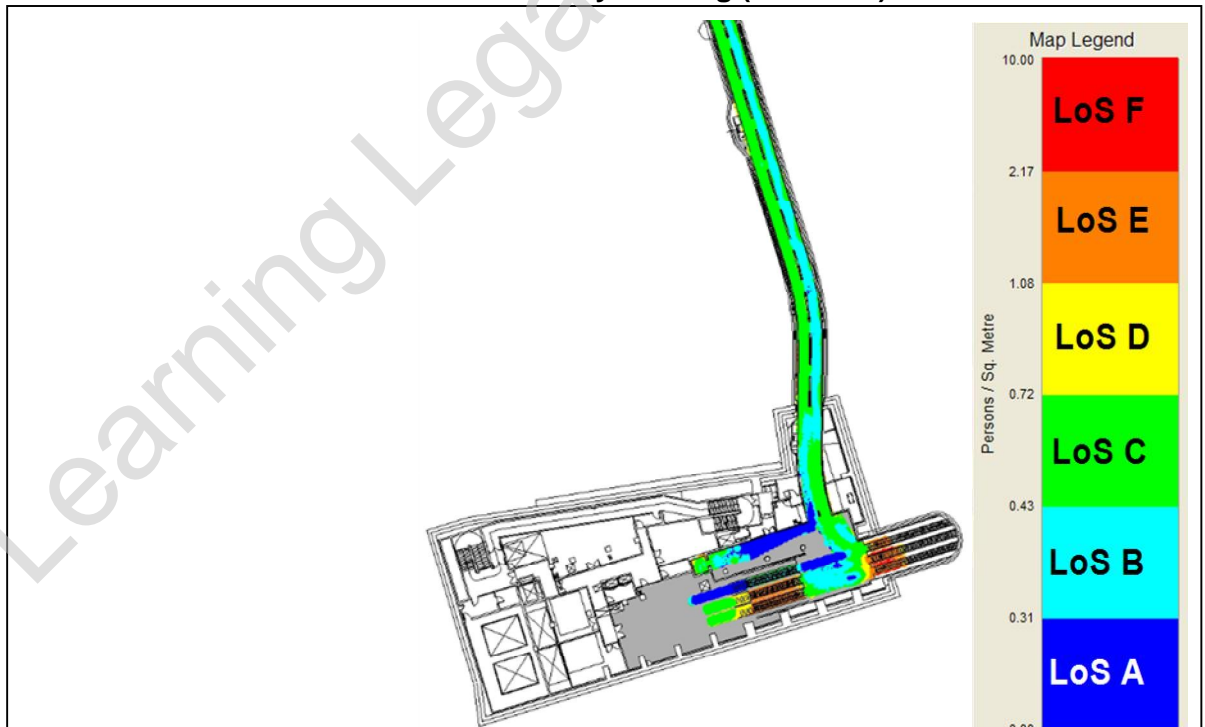
AM Peak 2026 Stage E Design Intermediate Level  
 Cumulative Mean Density Queuing (8:30-8:45)



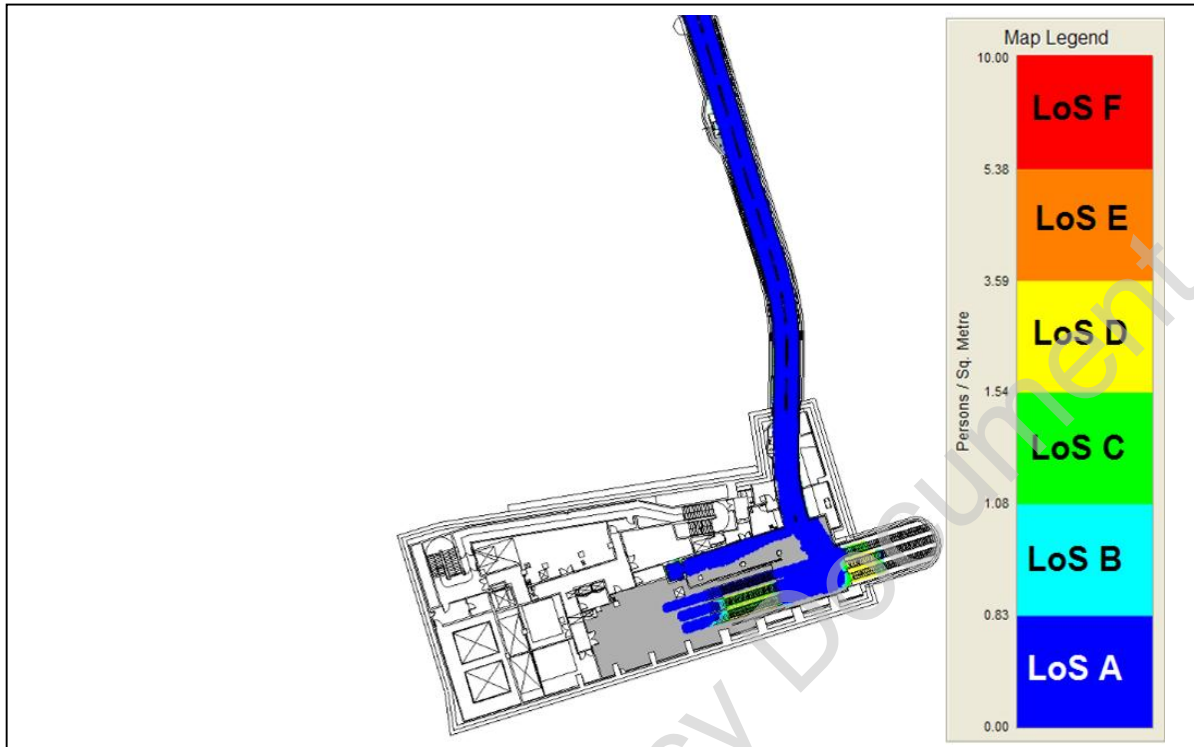
**AM Peak 2026 Stage E Design Intermediate Level  
 Cumulative High Density (8:30-8:45)**



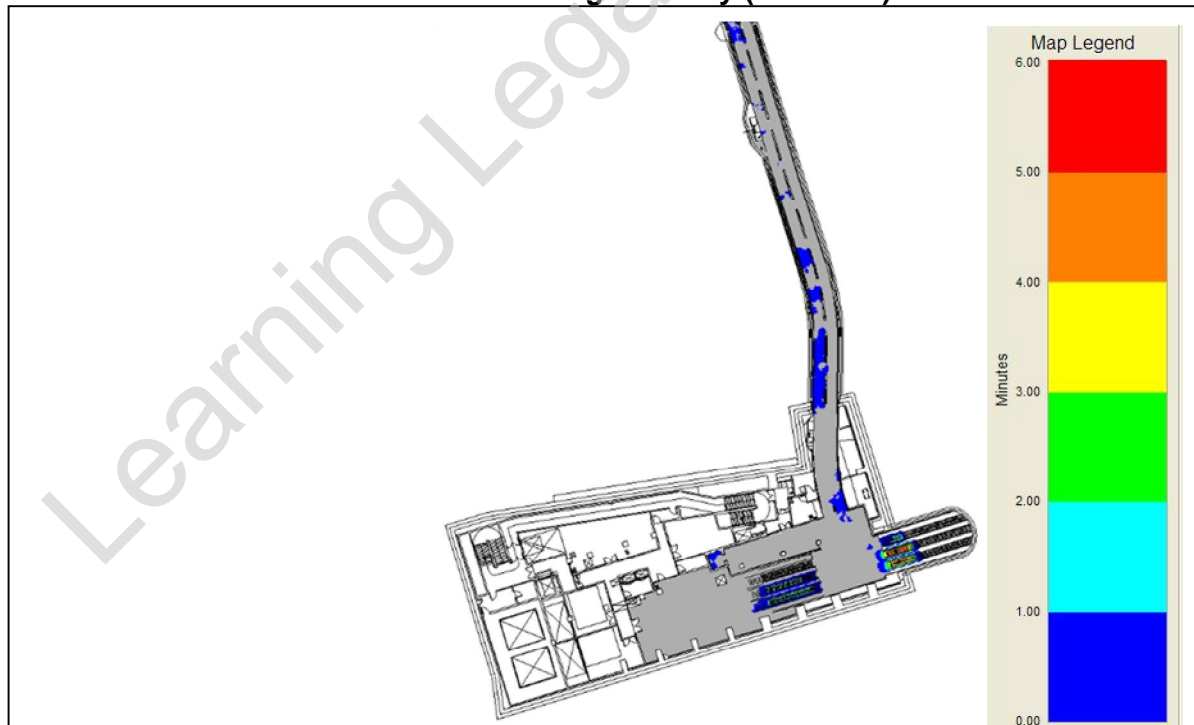
**AM Peak 2026 Stage E Design Intermediate Level  
 Cumulative Mean Density Walking (8:45-9:00)**



**AM Peak 2026 Stage E Design Intermediate Level  
 Cumulative Mean Density Queuing (8:45-9:00)**

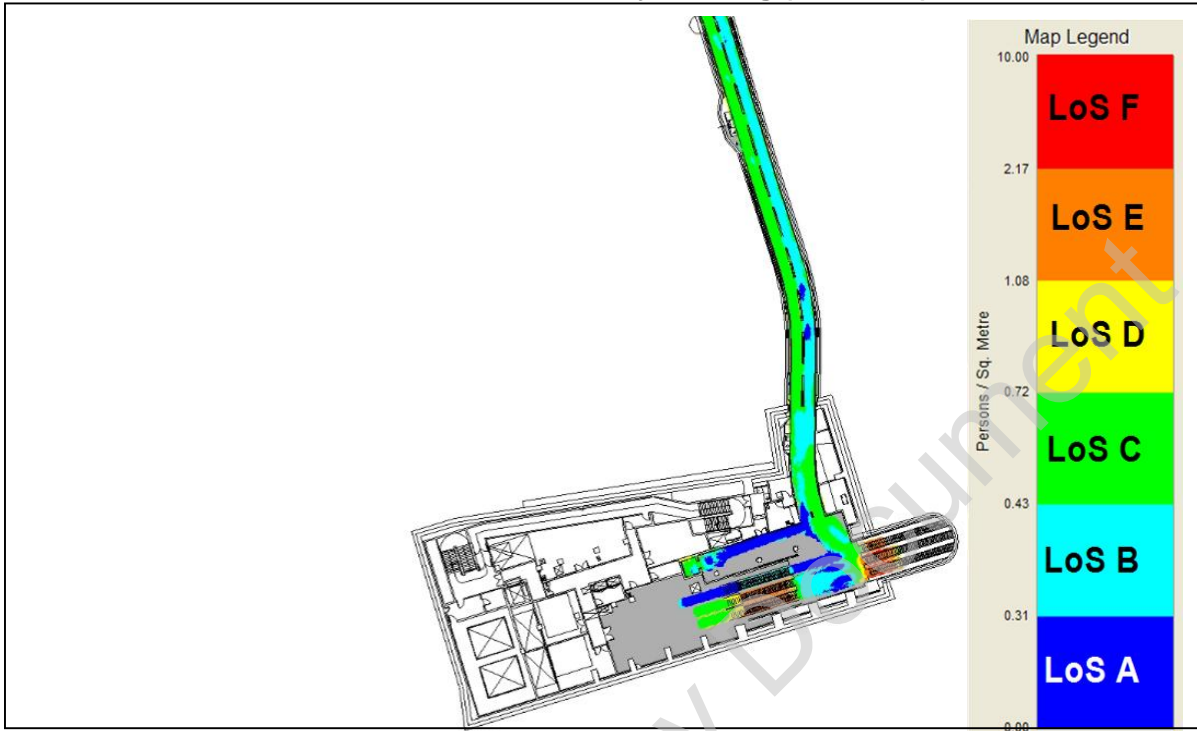


**AM Peak 2026 Stage E Design Intermediate Level  
 Cumulative High Density (8:45-9:00)**

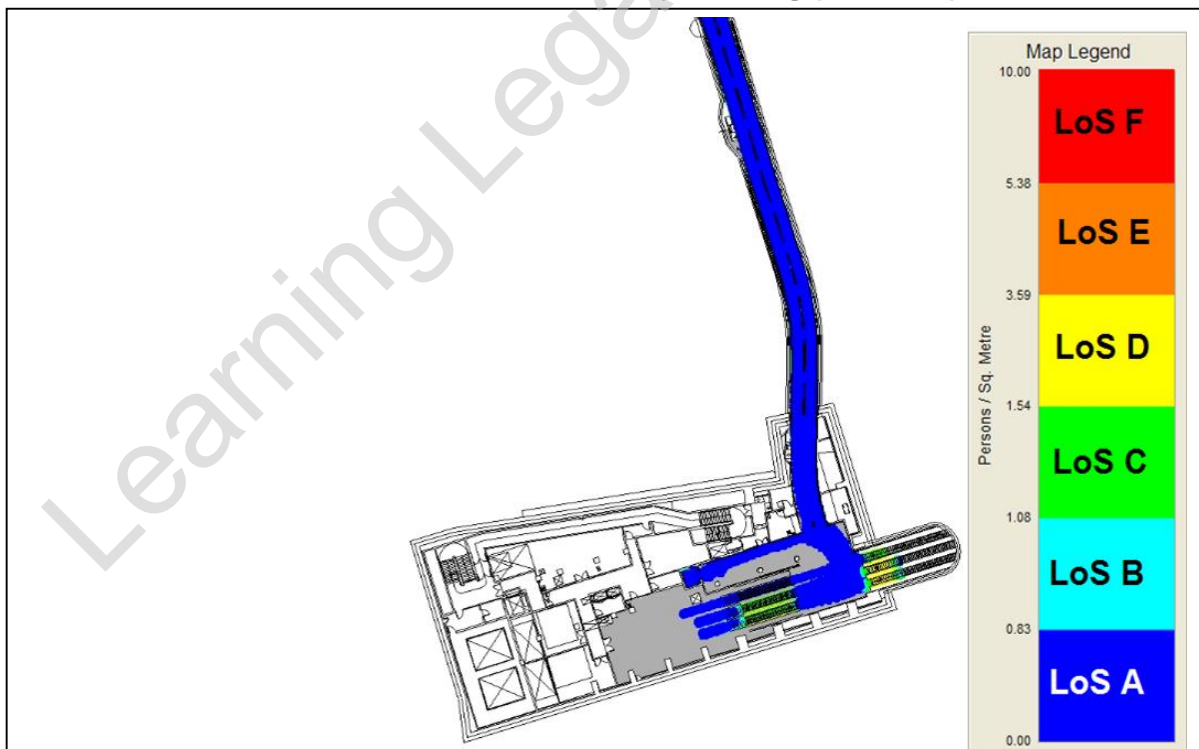




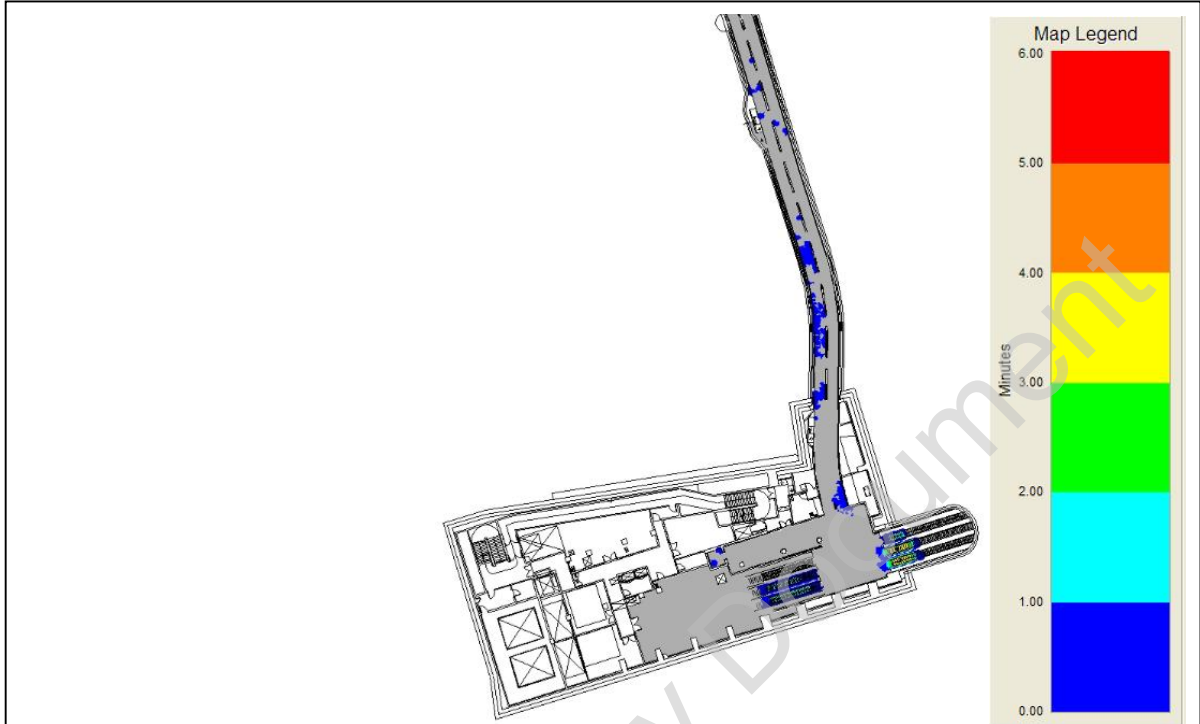
**AM Peak 2026 Stage E Design Intermediate Level  
 Cumulative Mean Density Walking (9:00-9:15)**



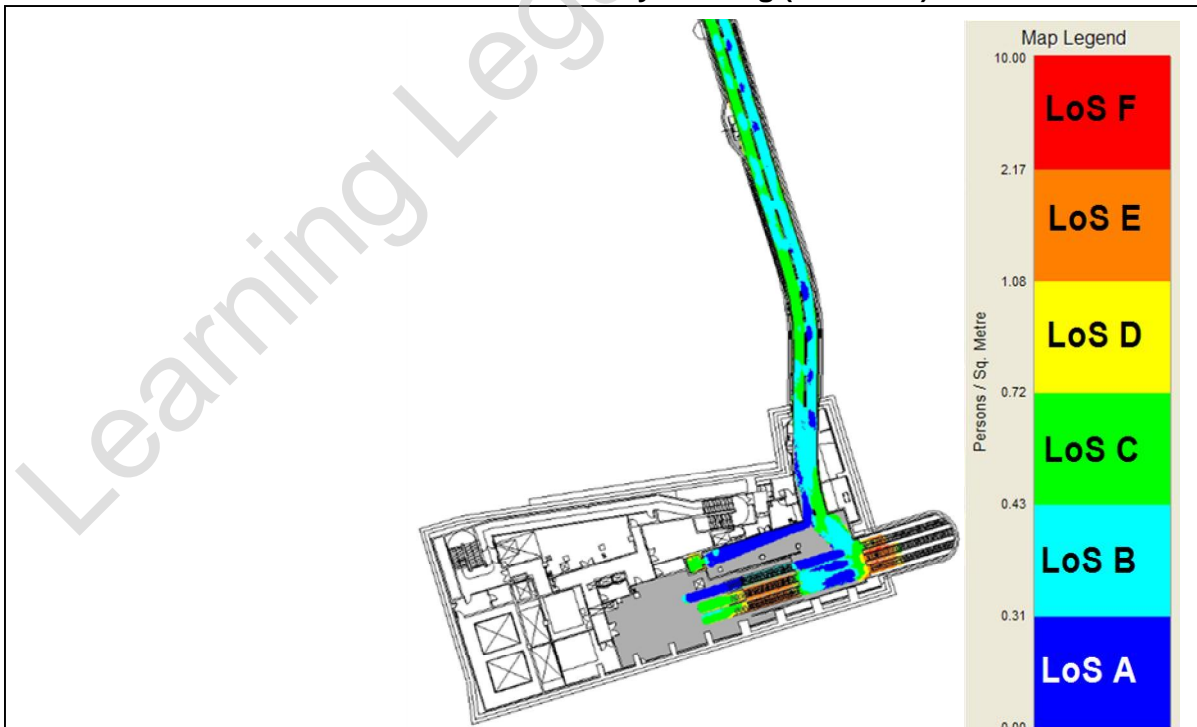
**AM Peak 2026 Stage E Design Intermediate Level  
 Cumulative Mean Density Queuing (9:00-9:15)**



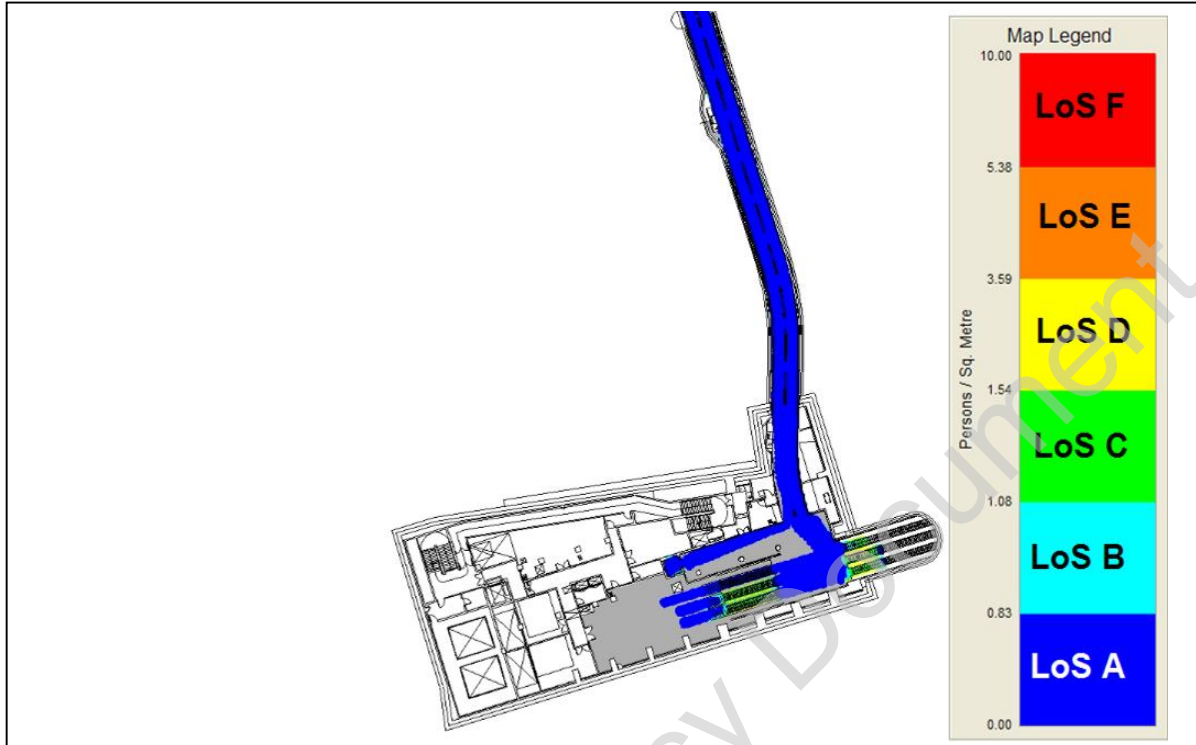
**AM Peak 2026 Stage E Design Intermediate Level  
 Cumulative High Density (9:00-9:15)**



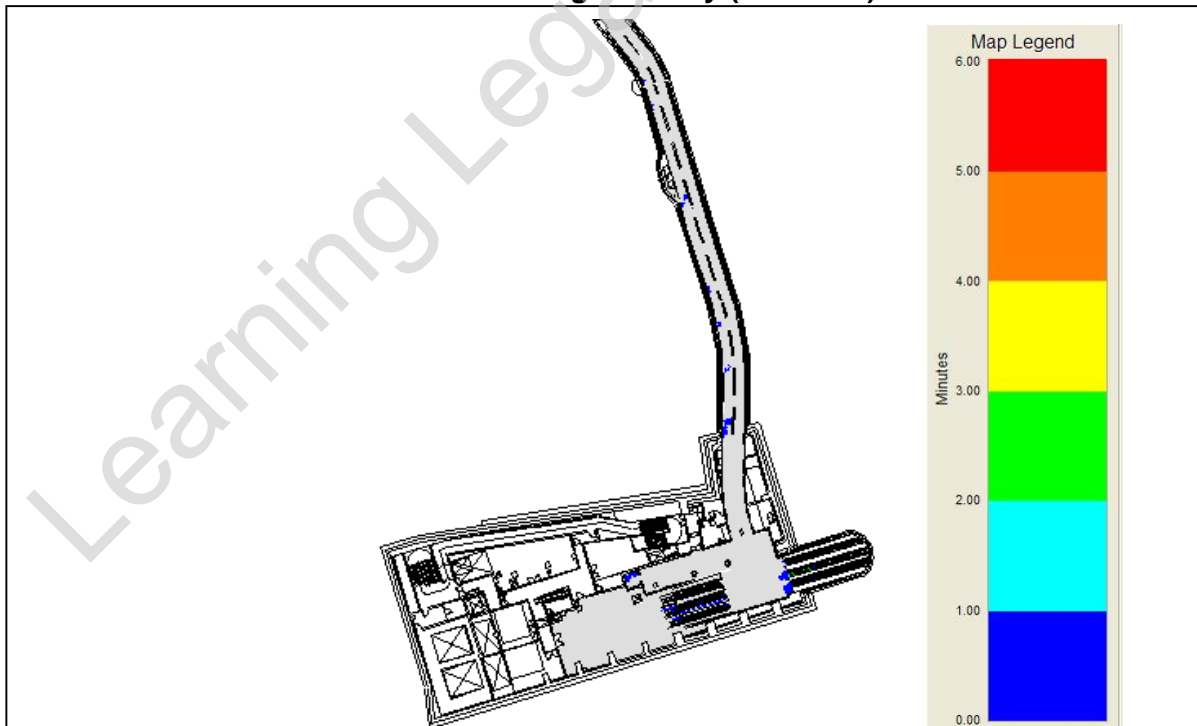
**AM Peak 2026 Stage E Design Intermediate Level  
 Cumulative Mean Density Walking (9:15-9:30)**



**AM Peak 2026 Stage E Design Intermediate Level  
 Cumulative Mean Density Queuing (9:15-9:30)**

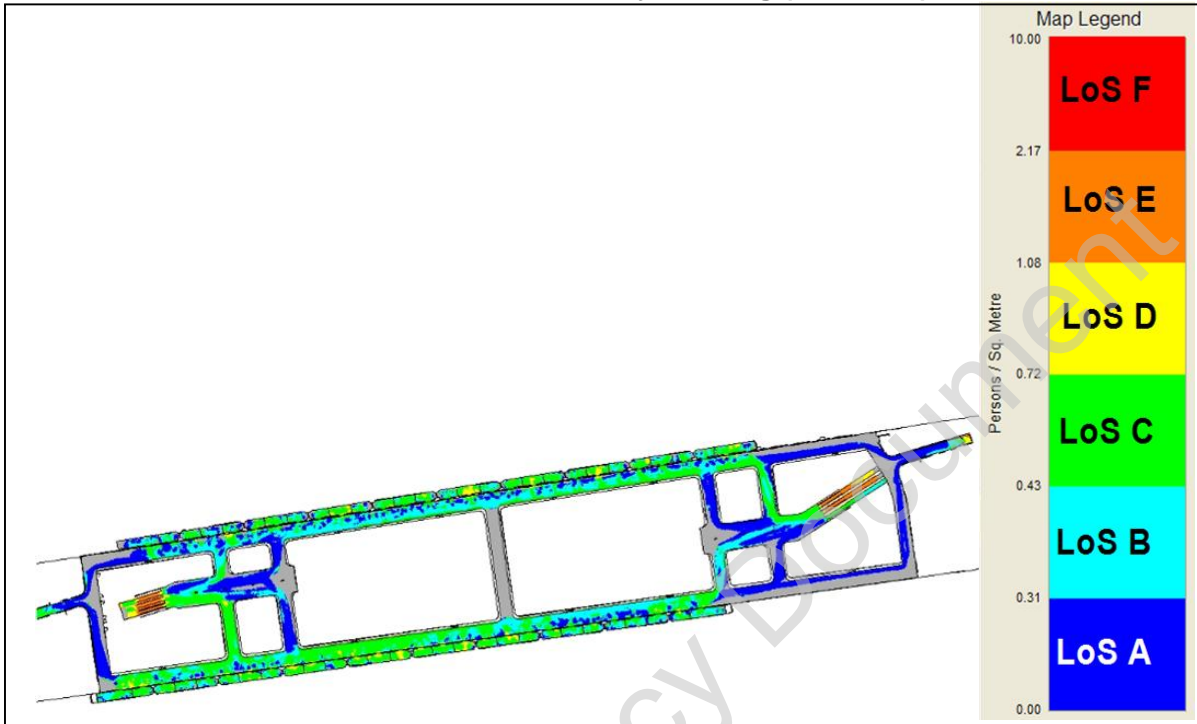


**AM Peak 2026 Stage E Design Intermediate Level  
 Cumulative High Density (9:15-9:30)**

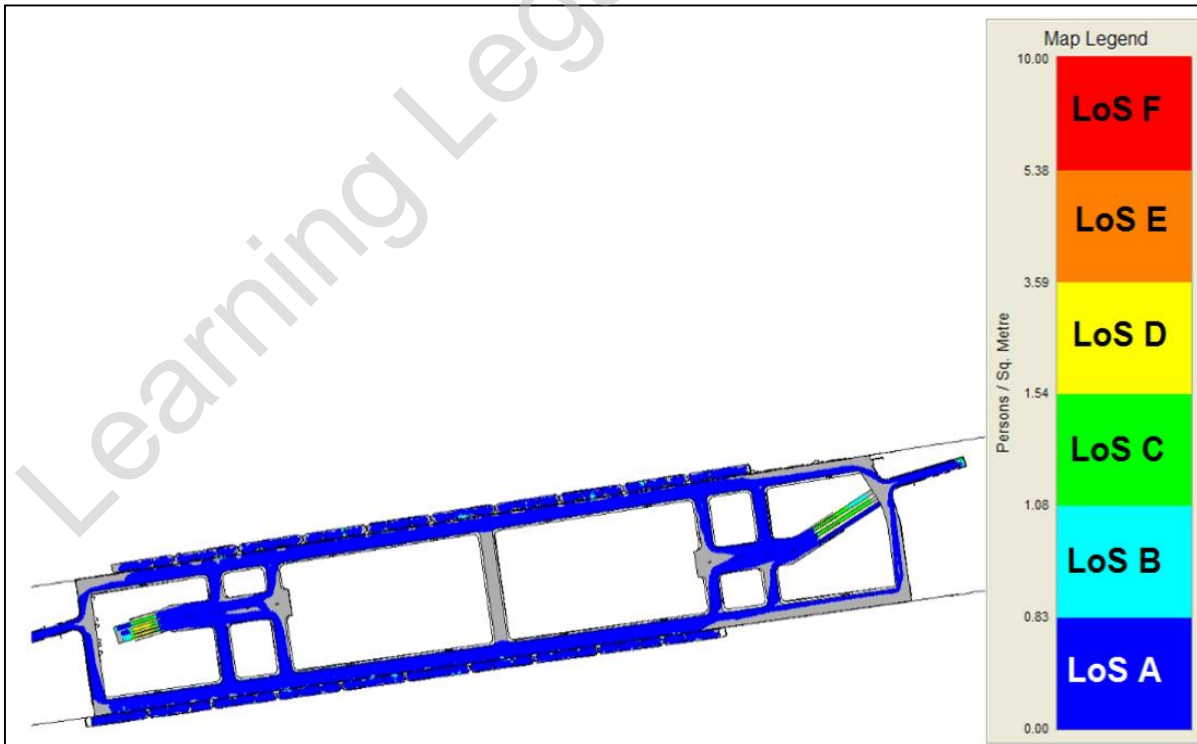


Platform Level

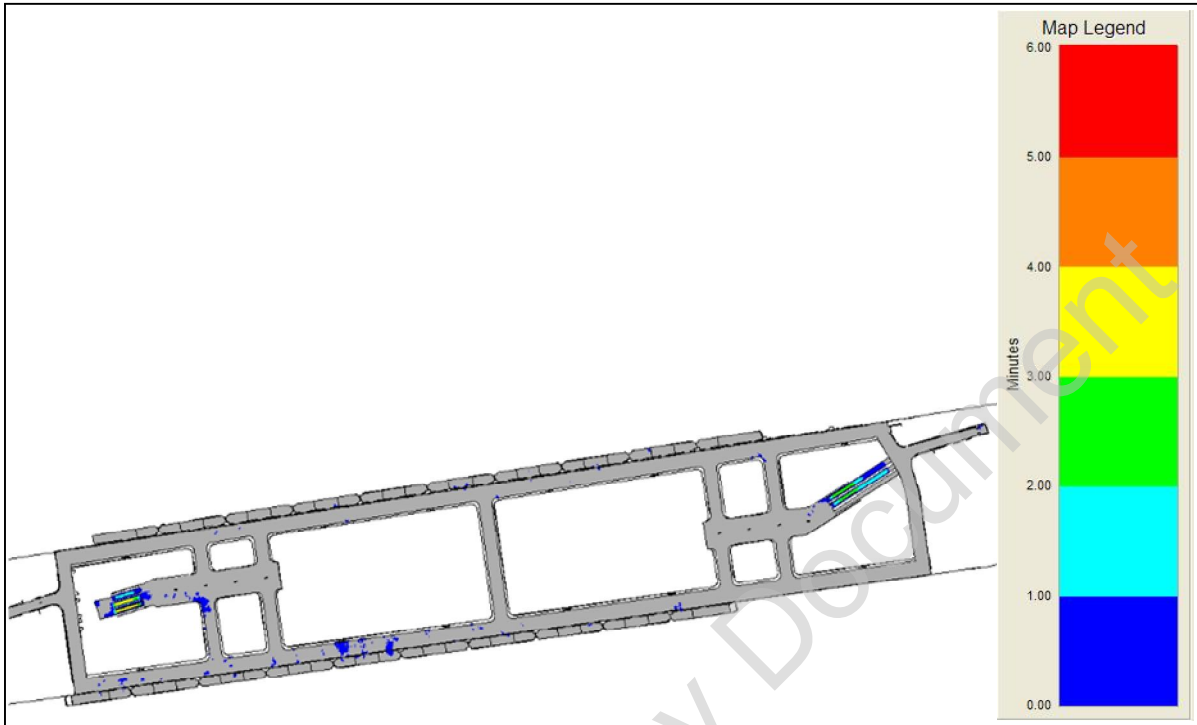
AM Peak 2026 Stage E Design Platform Level  
 Cumulative Mean Density Walking (8:30-8:45)



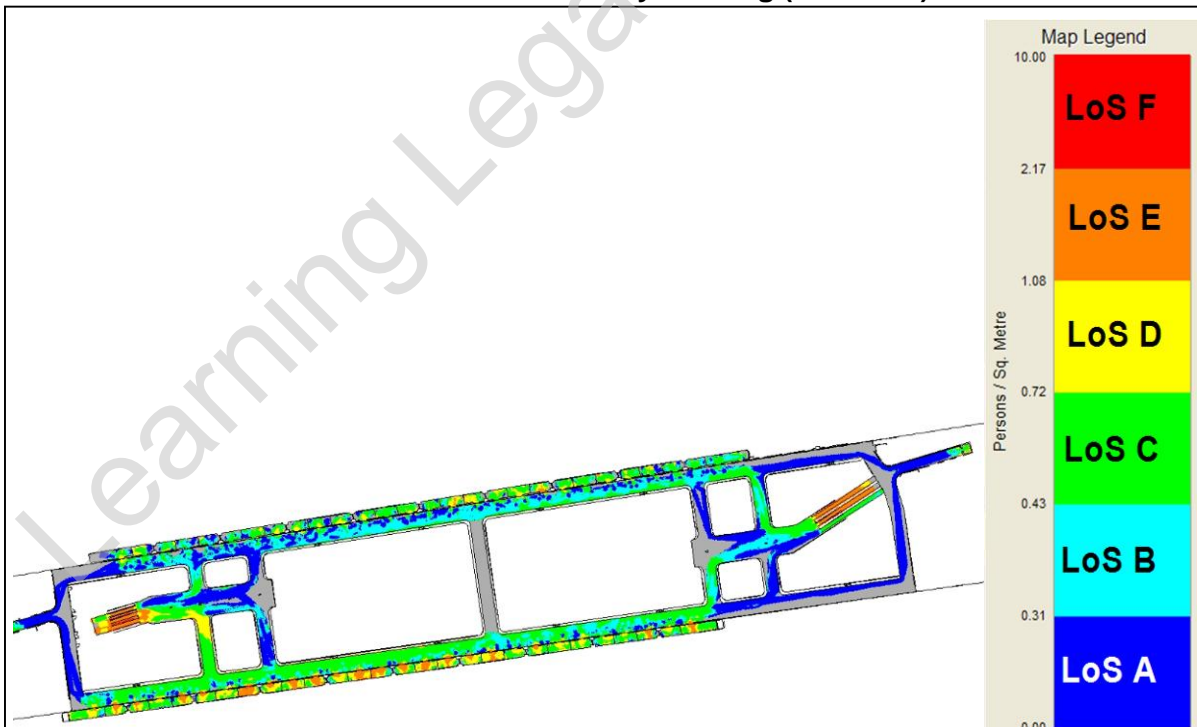
AM Peak 2026 Stage E Design Platform Level  
 Cumulative Mean Density Queuing (8:30-8:45)



**AM Peak 2026 Stage E Design Platform Level  
 Cumulative High Density (8:30-8:45)**



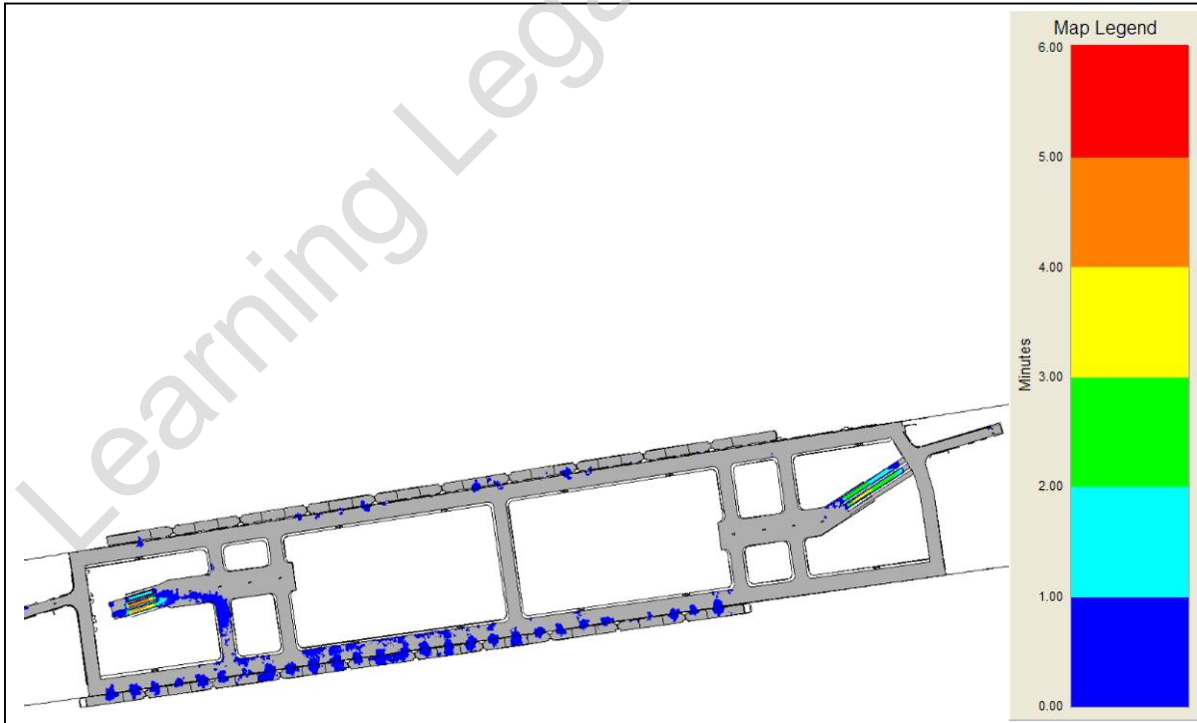
**AM Peak 2026 Stage E Design Platform Level  
 Cumulative Mean Density Walking (8:45-9:00)**



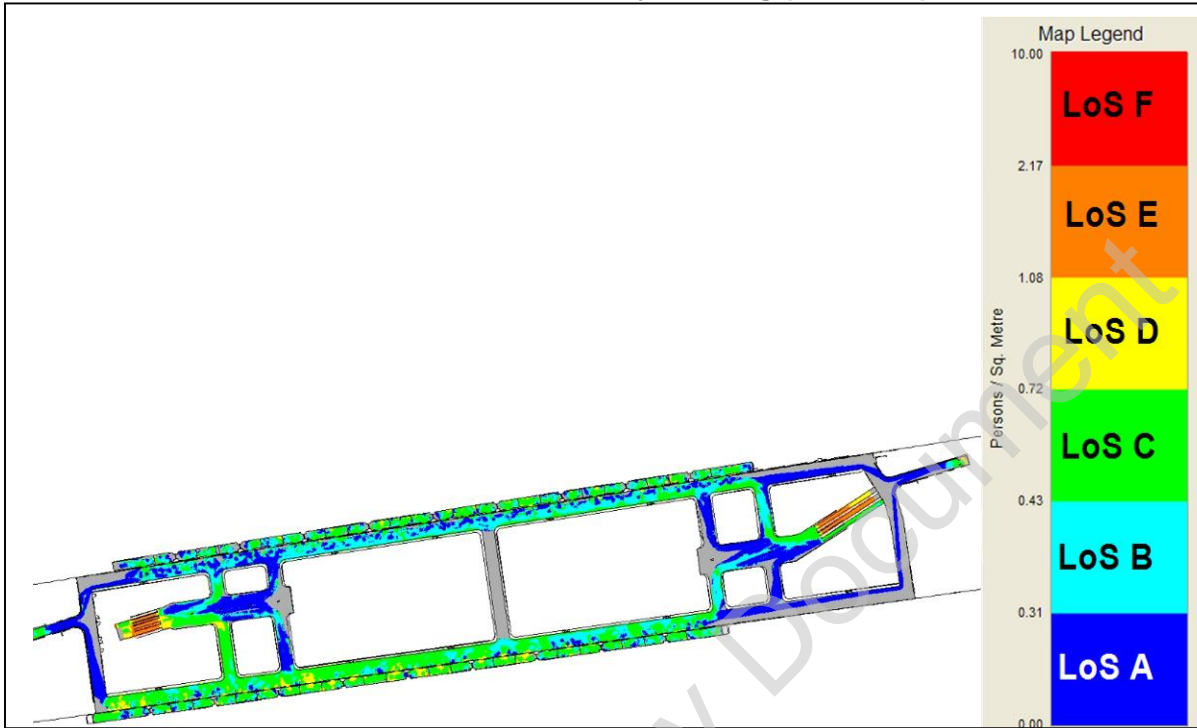
**AM Peak 2026 Stage E Design Platform Level  
 Cumulative Mean Density Queuing (8:45-9:00)**



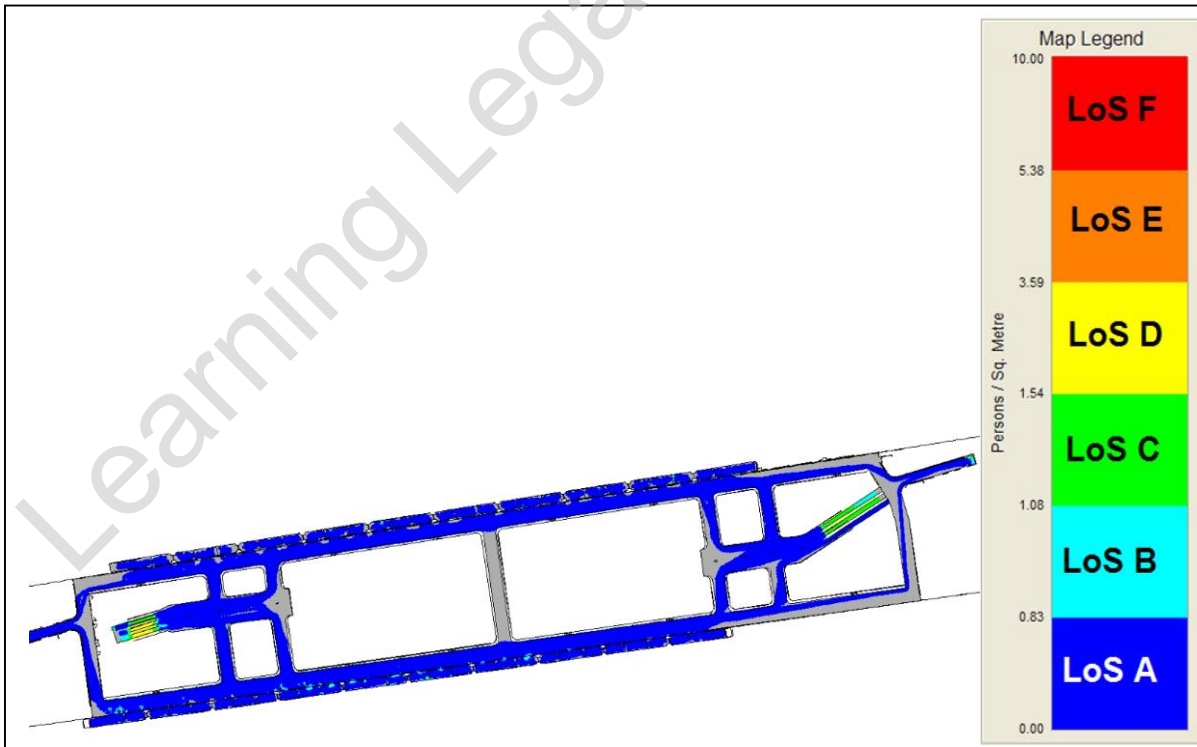
**AM Peak 2026 Stage E Design Platform Level  
 Cumulative High Density (8:45-9:00)**



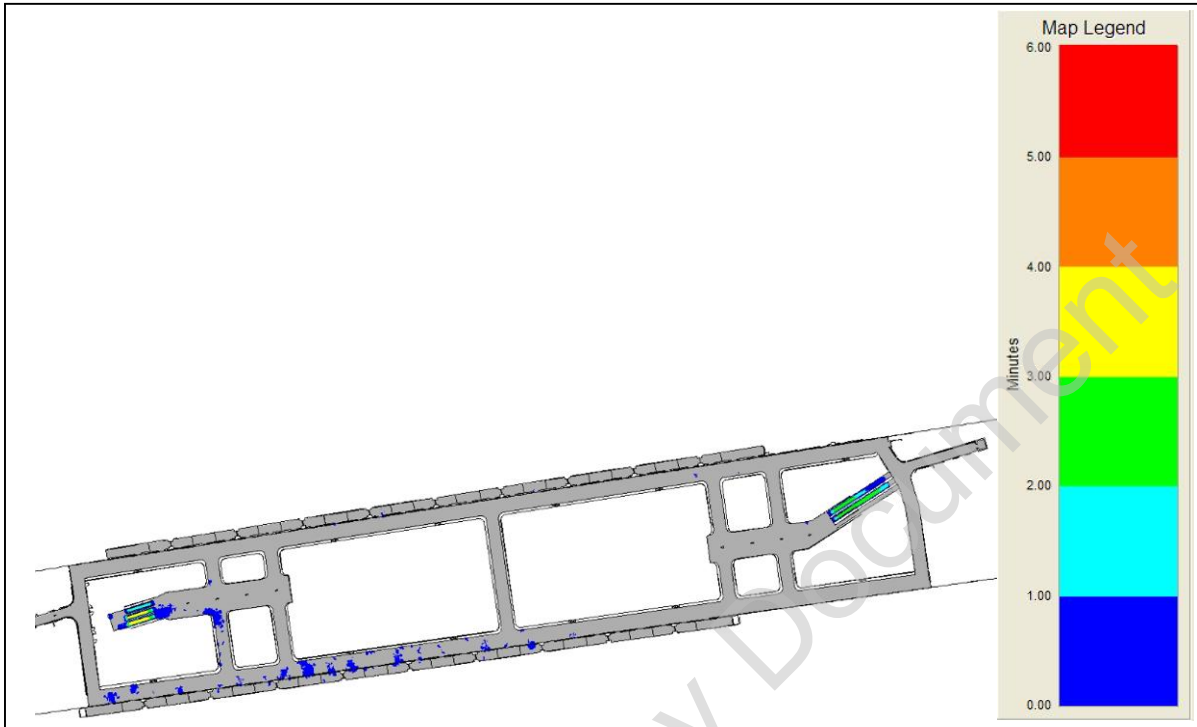
**AM Peak 2026 Stage E Design Platform Level  
 Cumulative Mean Density Walking (9:00-9:15)**



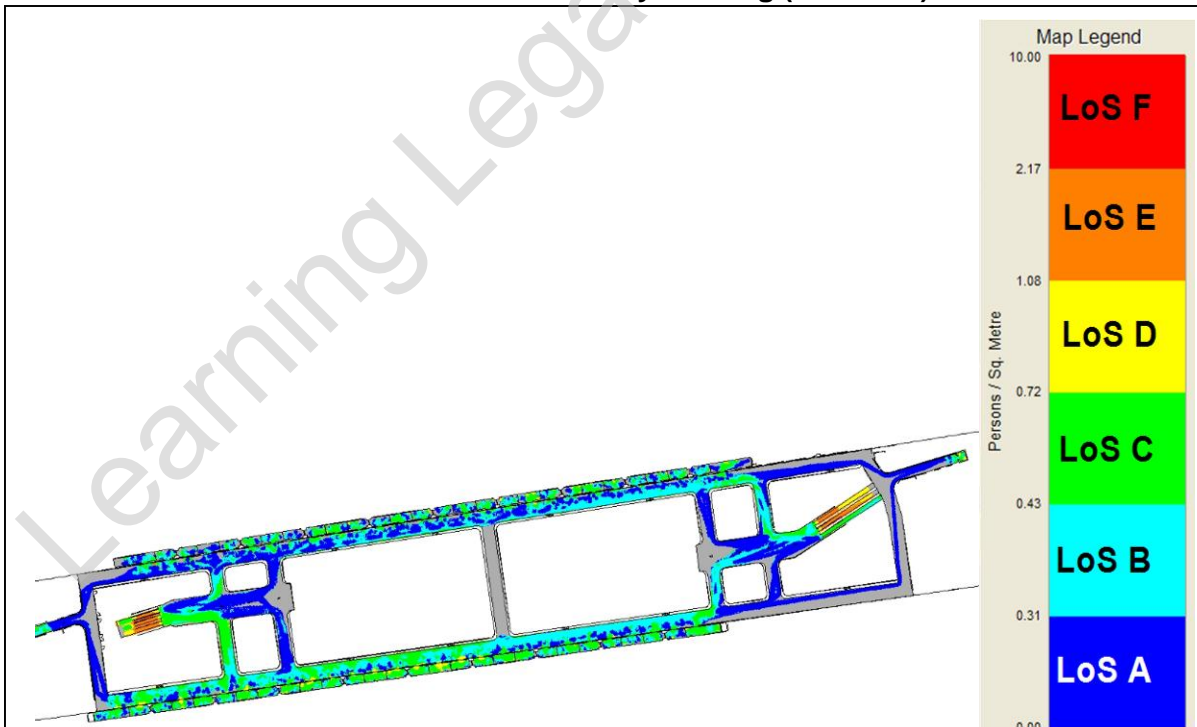
**AM Peak 2026 Stage E Design Platform Level  
 Cumulative Mean Density Queuing (9:00-9:15)**



**AM Peak 2026 Stage E Design Platform Level  
 Cumulative High Density (9:00-9:15)**

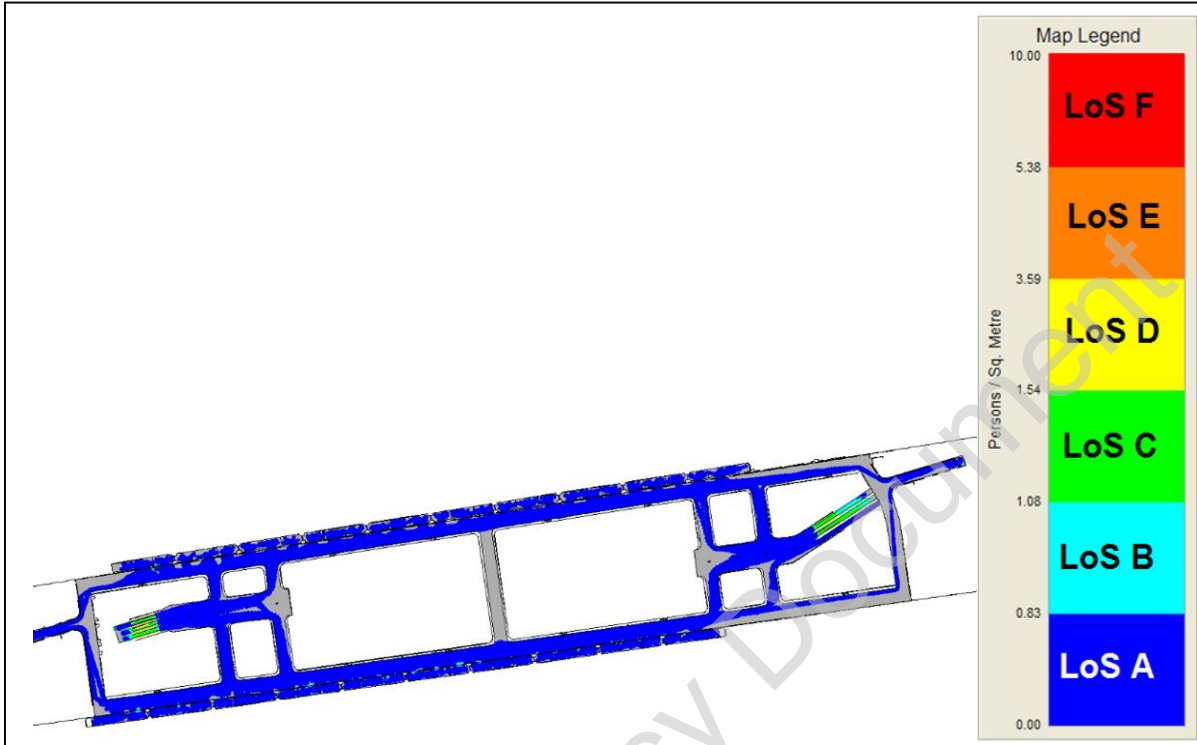


**AM Peak 2026 Stage E Design Platform Level  
 Cumulative Mean Density Walking (9:15-9:30)**

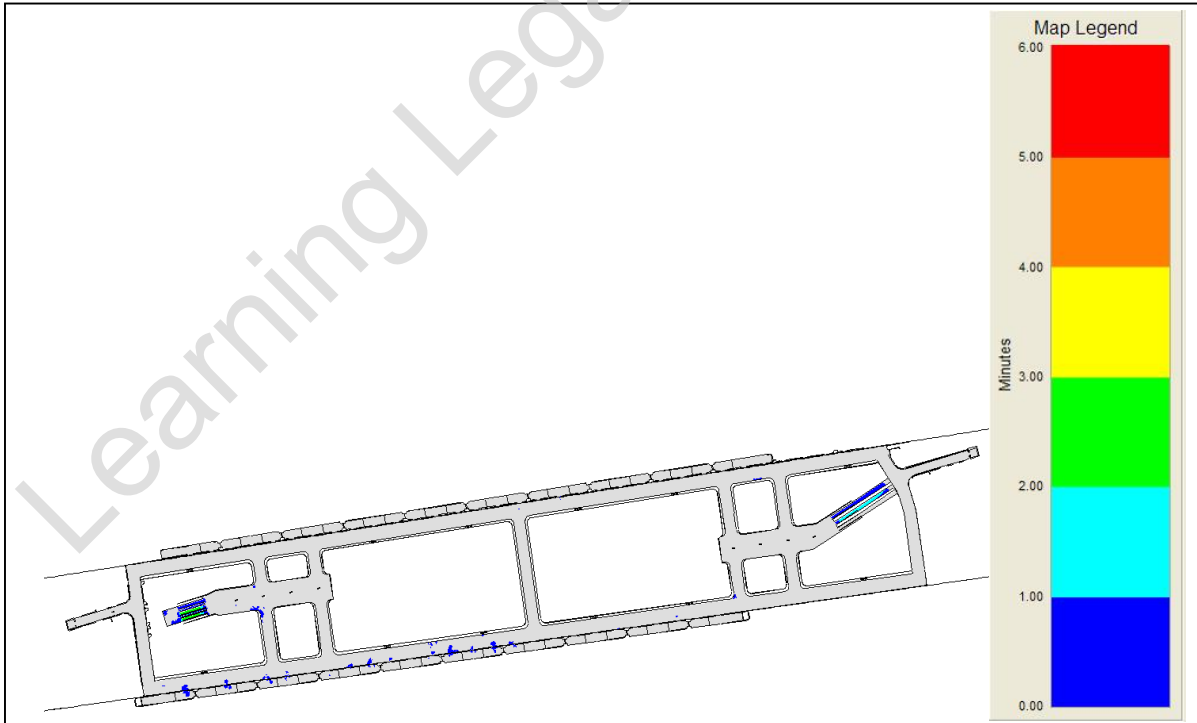




**AM Peak 2026 Stage E Design Platform Level  
 Cumulative Mean Density Queuing (9:15-9:30)**



**AM Peak 2026 Stage E Design Platform Level  
 Cumulative High (9:15-9:30)**



## Appendix F – AM 2026+28% Density Maps

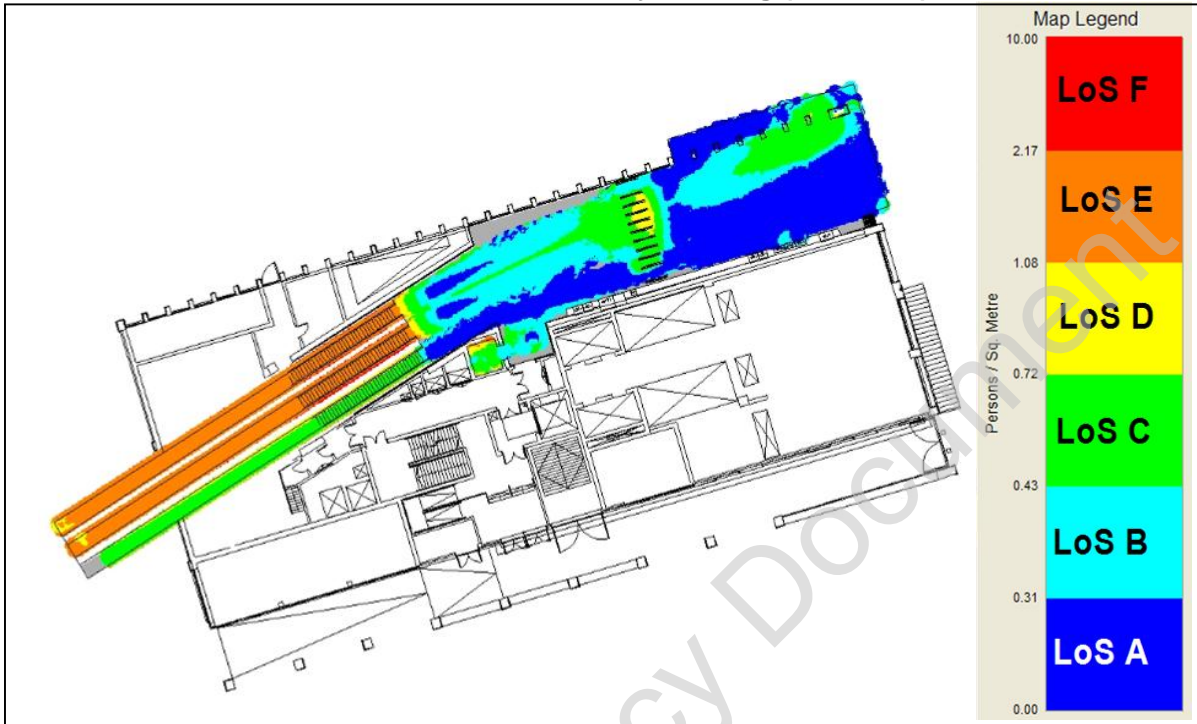
Cumulative Mean Density (CMD) maps provide the average density conditions that occur within the peak 15 minutes these are presented in 15 minute segments for the peak hour (8:30-9:30).

Cumulative High Density Maps (CHD) maps shows how long various areas of a site have registered densities greater than 1.54 passengers/sq.metre (LoS D for queuing). The range of colours represent time, in 1 minute intervals (up to 6 minutes). The map is similar to a 'temperature' map: areas that have experienced high levels of density for a long time appear red; those that have experienced shorter periods of density appear blue.

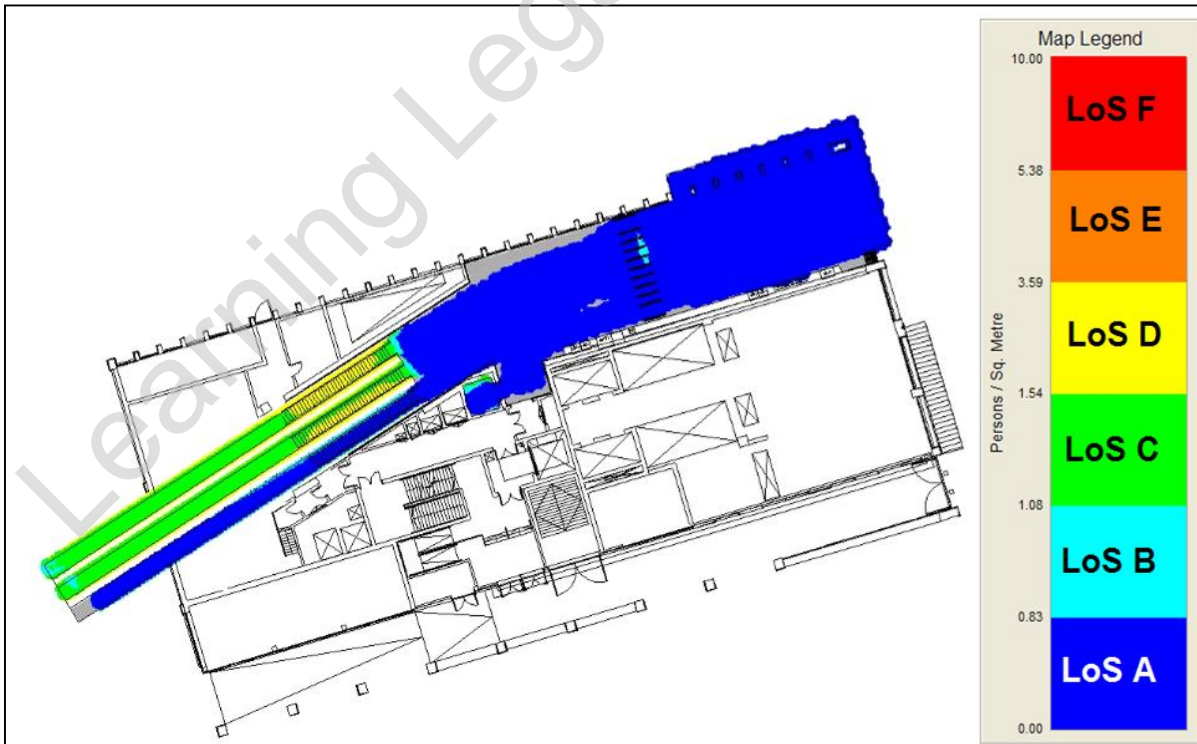
Learning Legacy Document

Hanover Square Ticket Hall

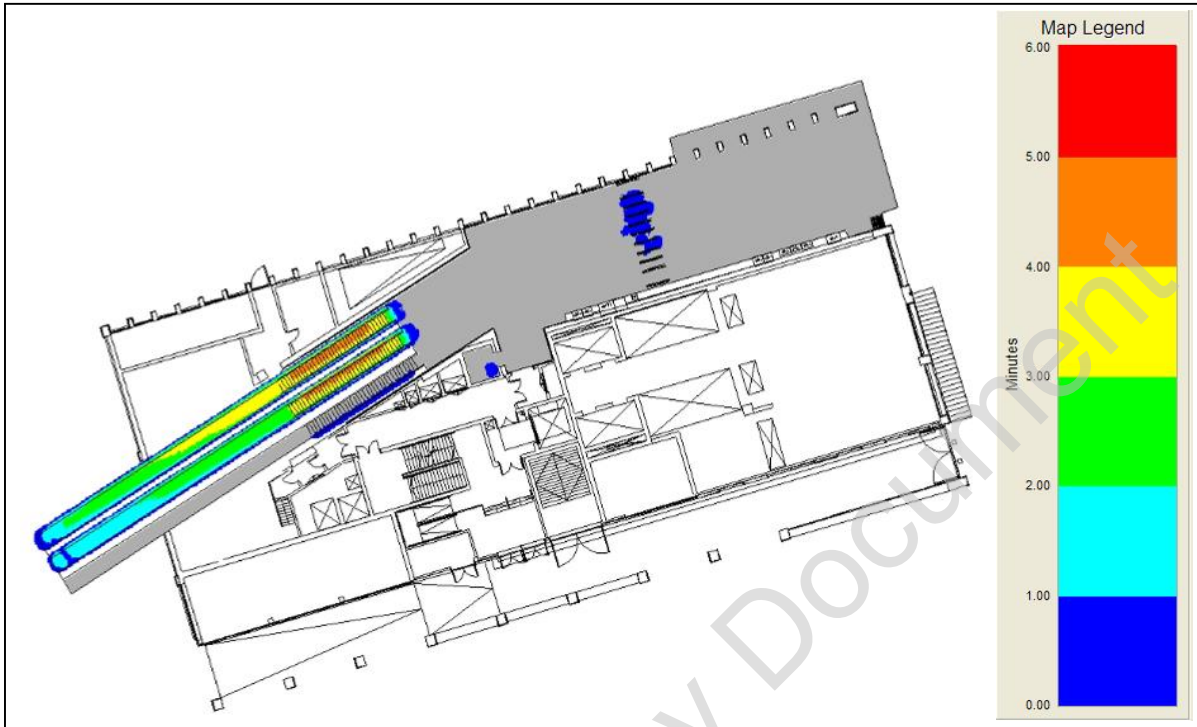
AM Peak 2026+28% Stage E Design Hanover Square Ticket Hall  
 Cumulative Mean Density Walking (8:30-8:45)



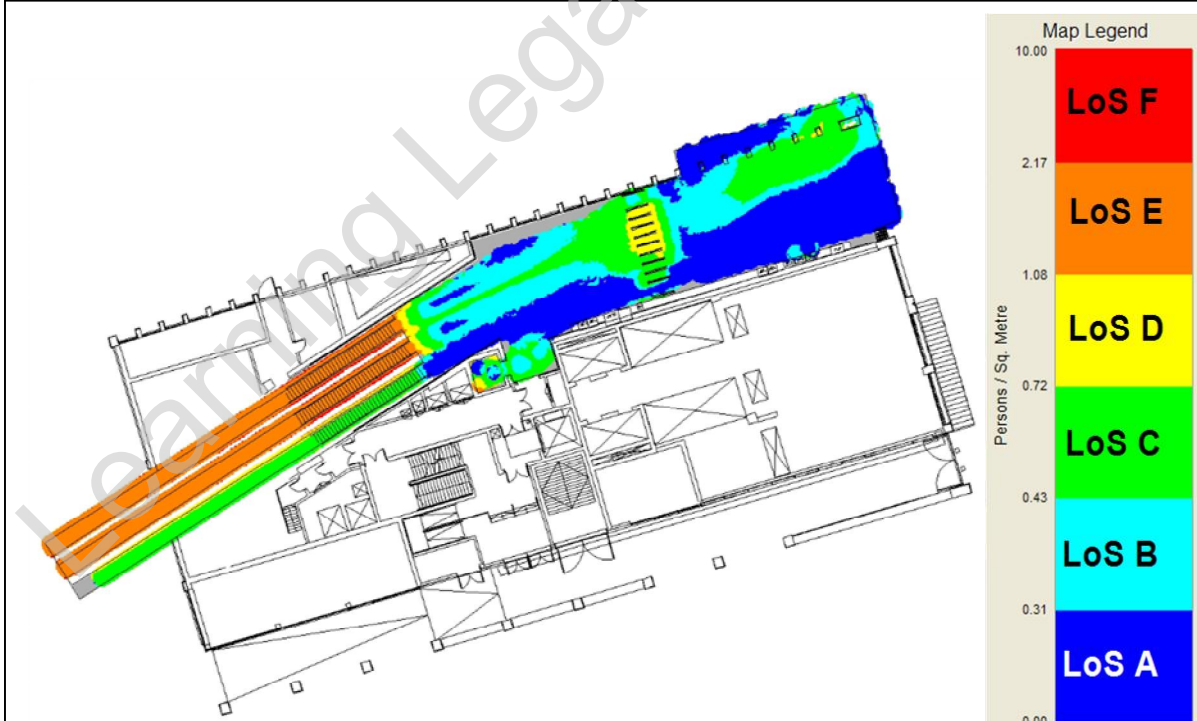
AM Peak 2026+28% Stage E Design Hanover Square Ticket Hall  
 Cumulative Mean Density Queuing (8:30-8:45)



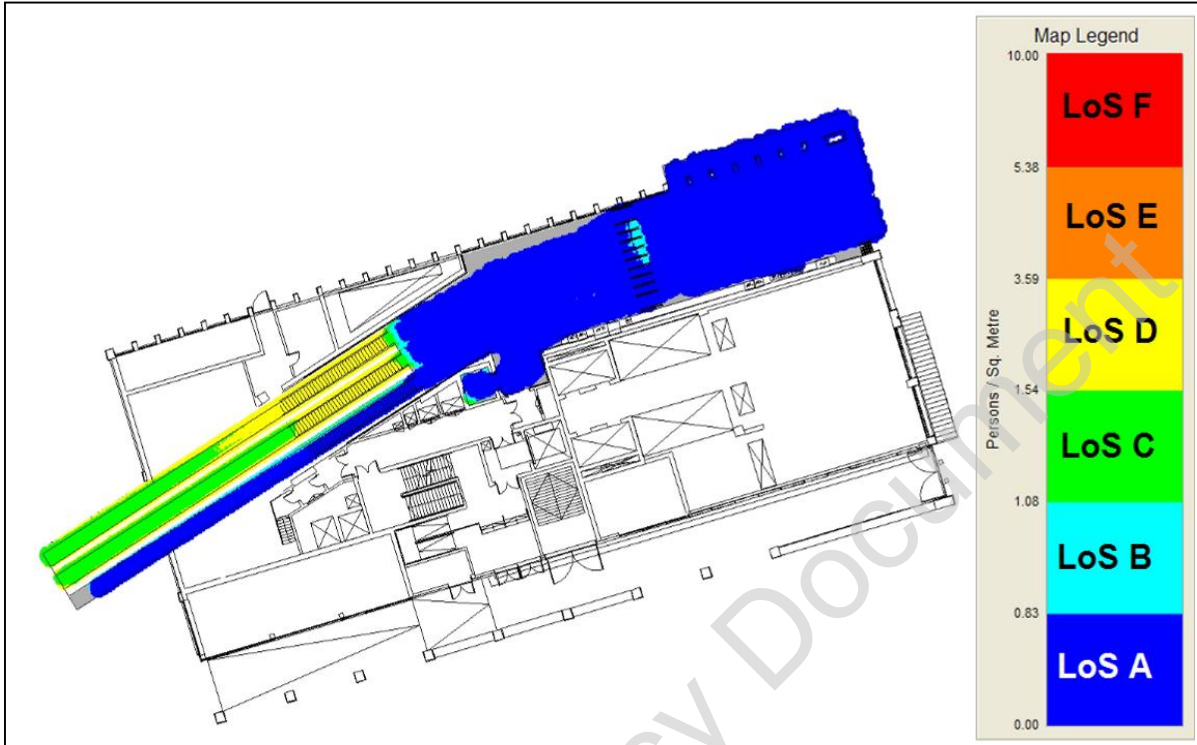
**AM Peak 2026+28% Stage E Design Hanover Square Ticket Hall  
 Cumulative High Density (8:30-8:45)**



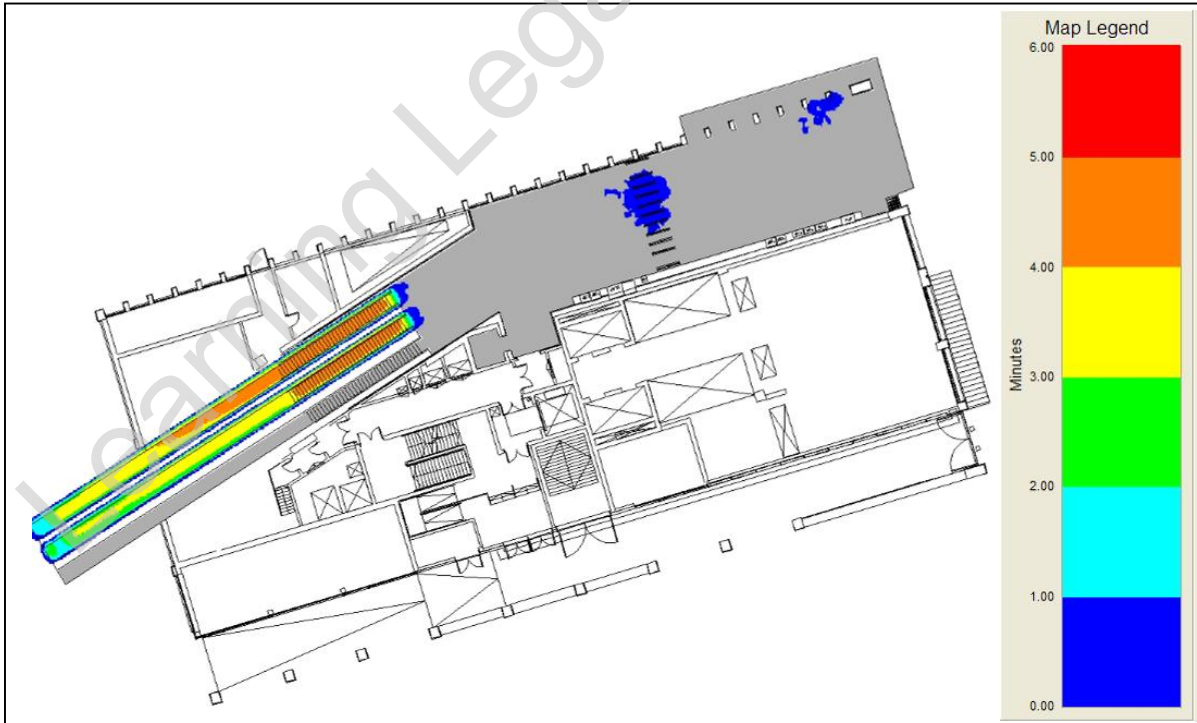
**AM Peak 2026+28% Stage E Design Hanover Square Ticket Hall  
 Cumulative Mean Density Walking (8:45-9:00)**



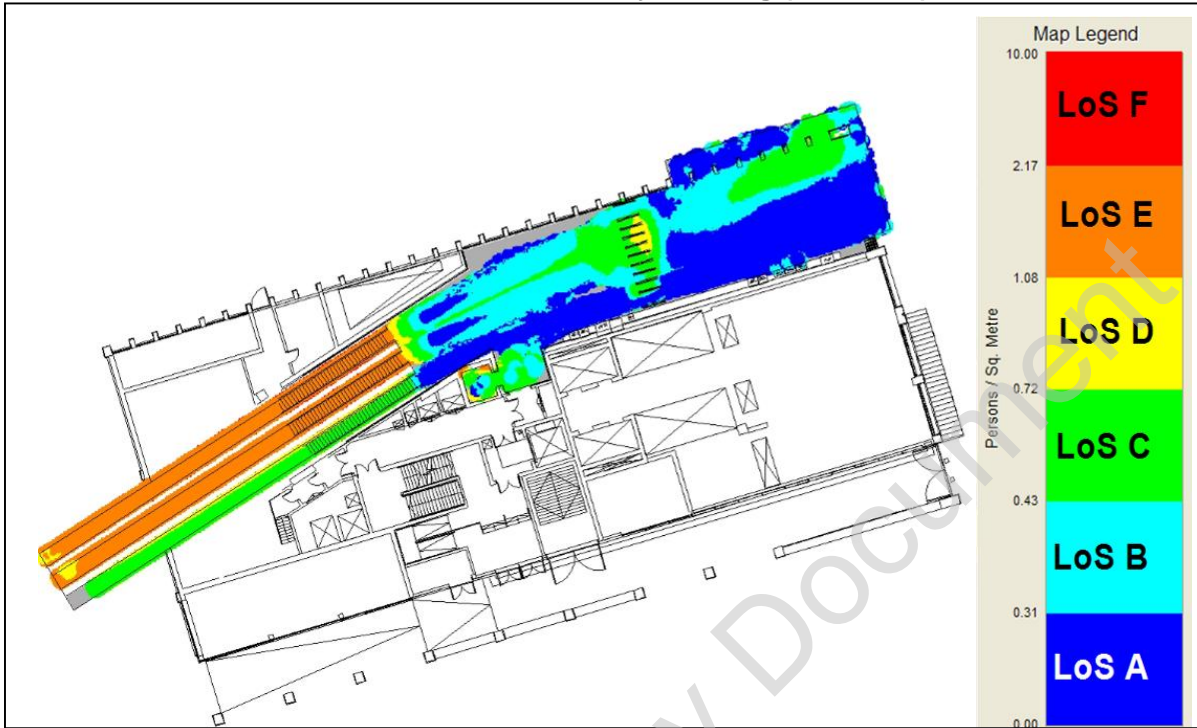
**AM Peak 2026+28% Stage E Design Hanover Square Ticket Hall  
 Cumulative Mean Density Queuing (8:45-9:00)**



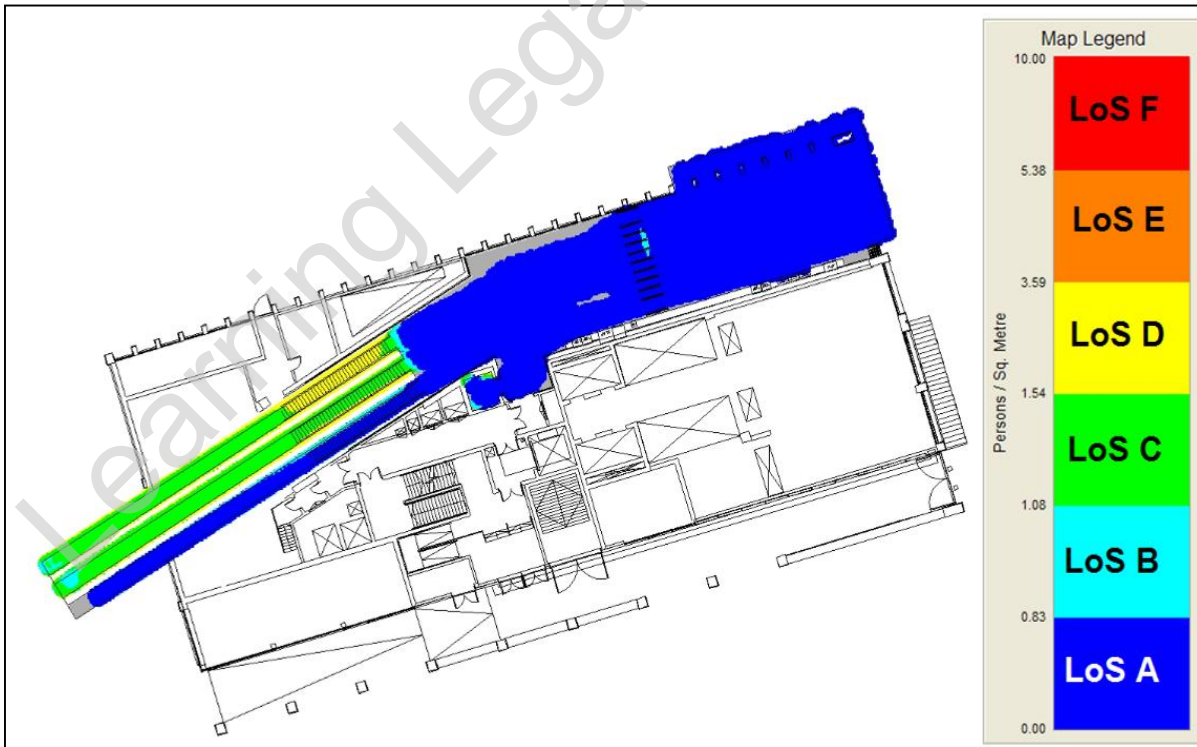
**AM Peak 2026+28% Stage E Design Hanover Square Ticket Hall  
 Cumulative High Density (8:45-9:00)**



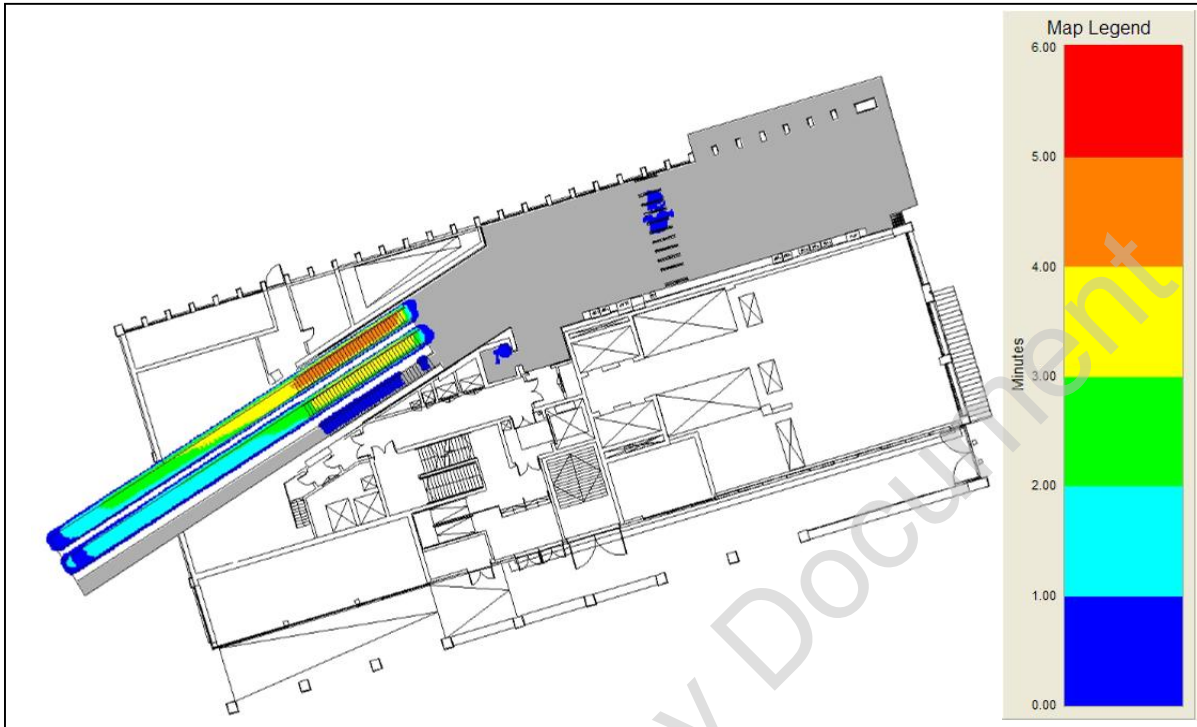
**AM Peak 2026+28% Stage E Design Hanover Square Ticket Hall  
 Cumulative Mean Density Walking (9:00-9:15)**



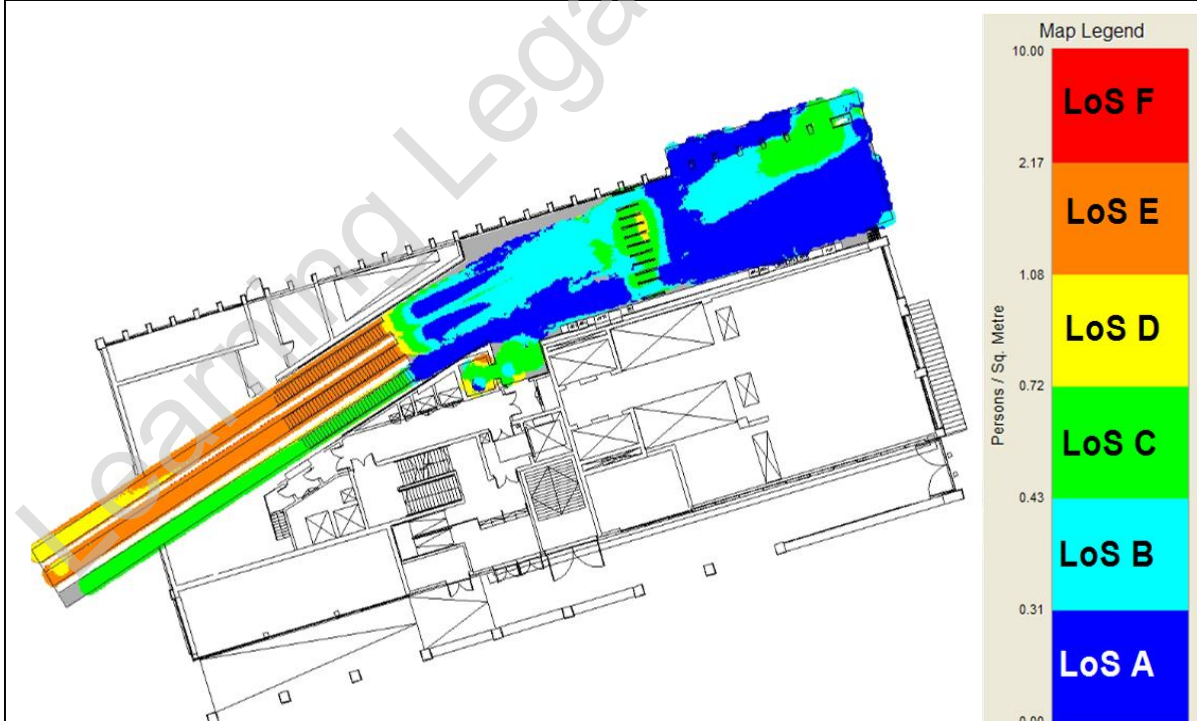
**AM Peak 2026+28% Stage E Design Hanover Square Ticket Hall  
 Cumulative Mean Density Queuing (9:00-9:15)**



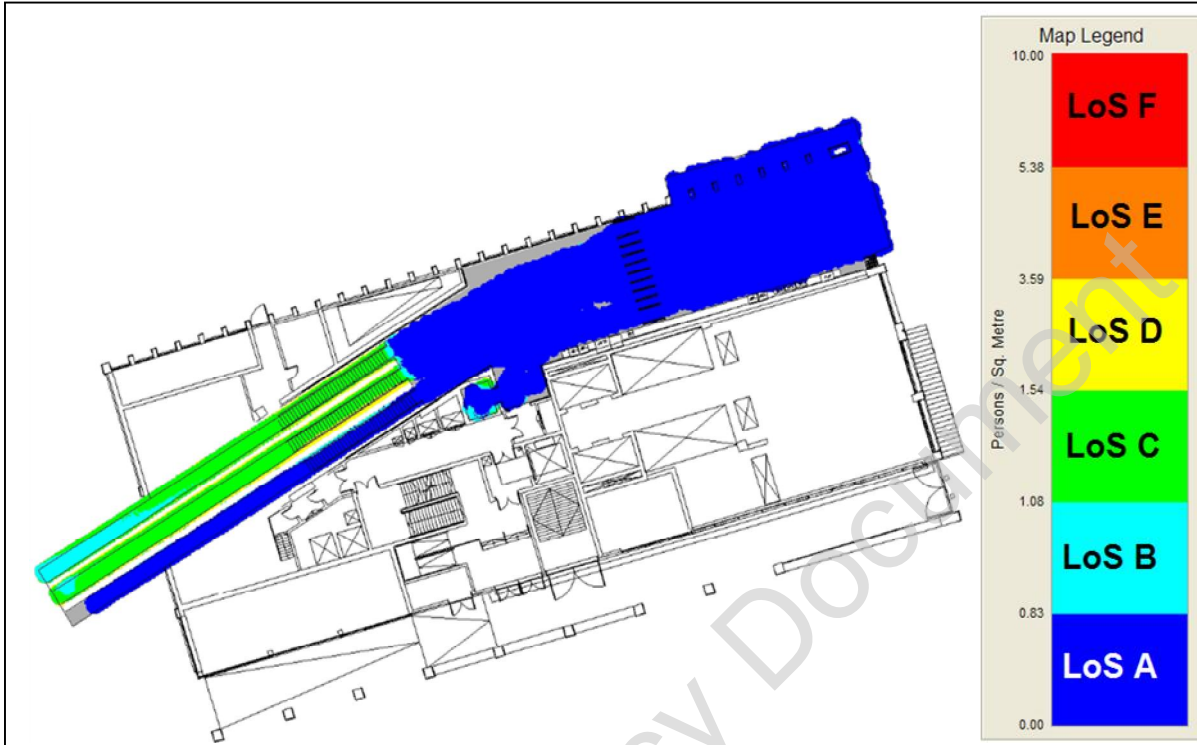
**AM Peak 2026+28% Stage E Design Hanover Square Ticket Hall  
 Cumulative High Density (9:00-9:15)**



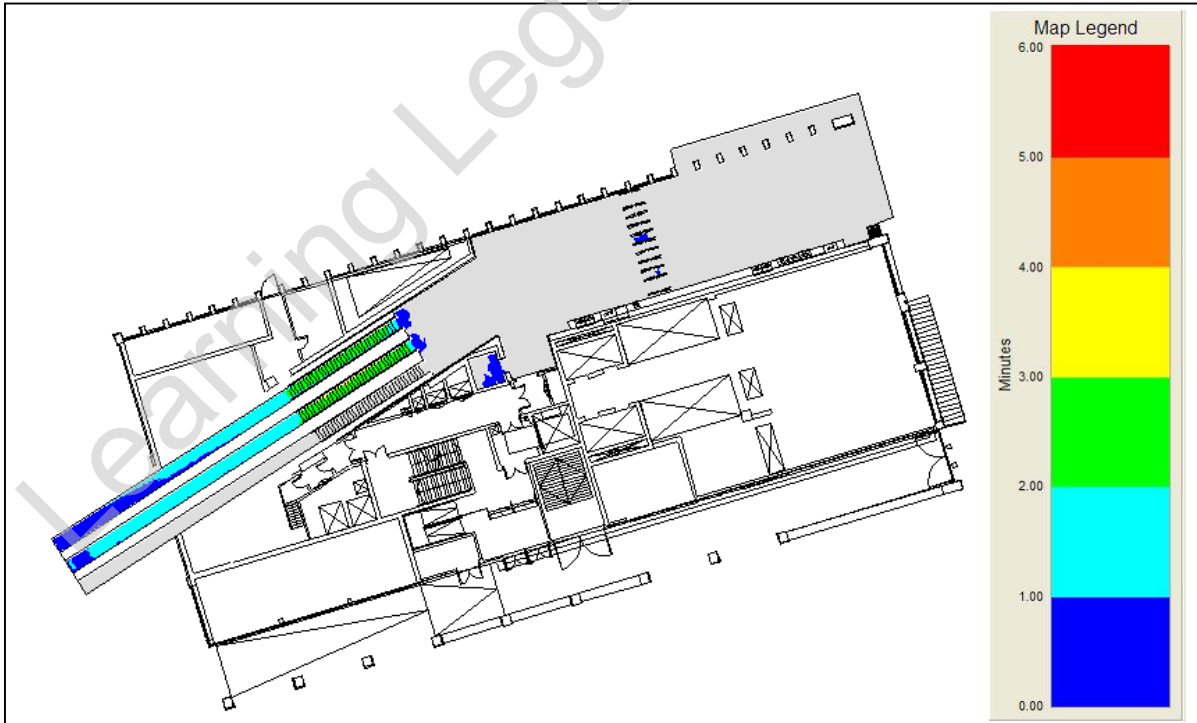
**AM Peak 2026+28% Stage E Design Hanover Square Ticket Hall  
 Cumulative Mean Density Walking (9:15-9:30)**



**AM Peak 2026+28% Stage E Design Hanover Square Ticket Hall  
 Cumulative Mean Density Queuing (9:15-9:30)**



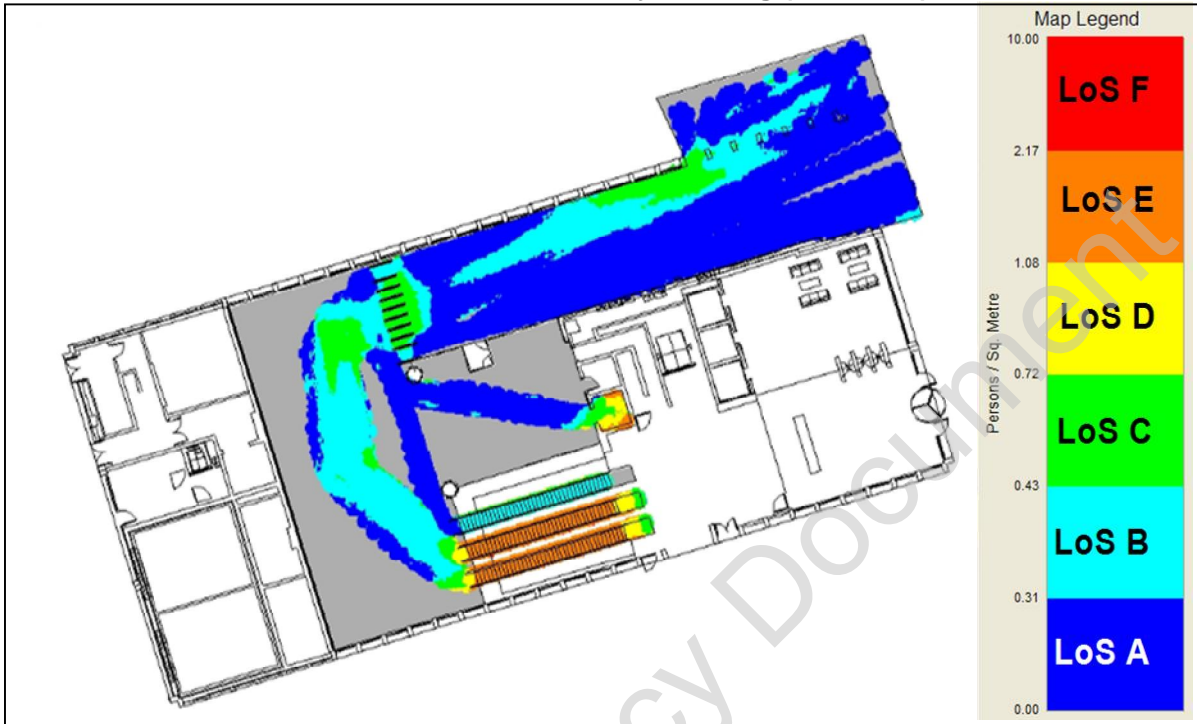
**AM Peak 2026+28% Stage E Design Hanover Square Ticket Hall  
 Cumulative High (9:15-9:30)**





Davies Street Ticket Hall

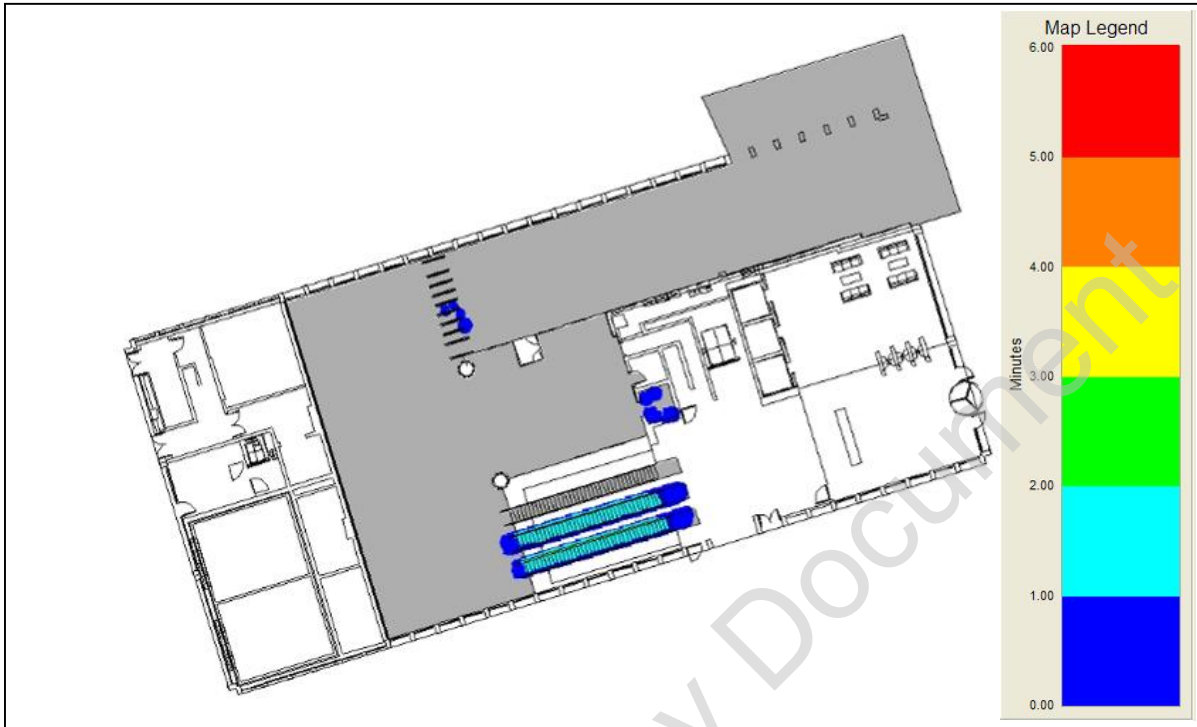
AM Peak 2026+28% Stage E Design Davies Street Ticket Hall  
 Cumulative Mean Density Walking (8:30-8:45)



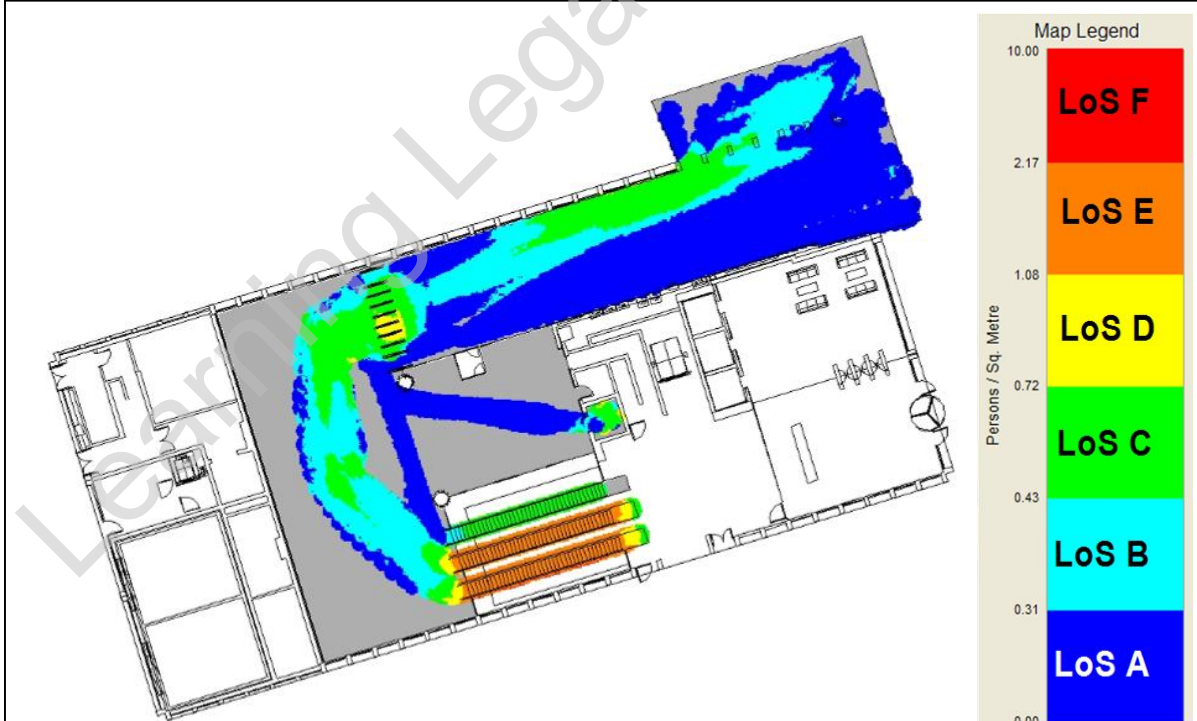
AM Peak 2026+28% Stage E Design Davies Street Ticket Hall  
 Cumulative Mean Density Queuing (8:30-8:45)



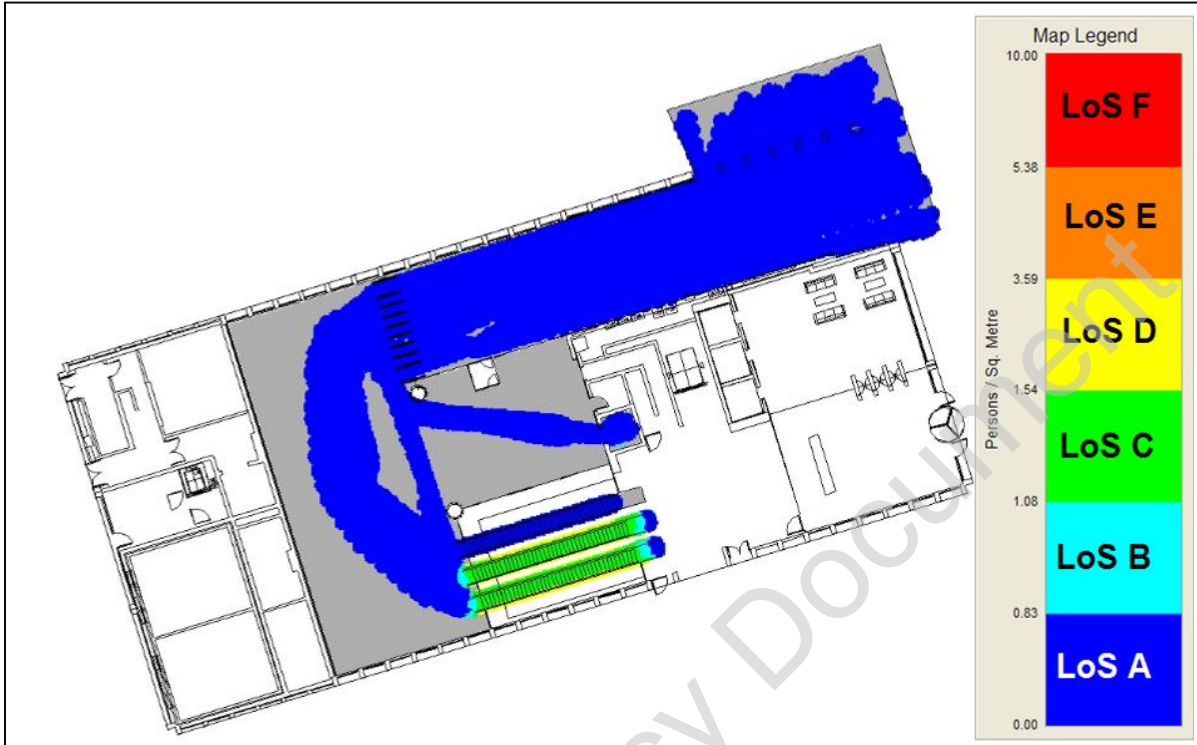
**AM Peak 2026+28% Stage E Design Davies Street Ticket Hall  
 Cumulative High Density (8:30-8:45)**



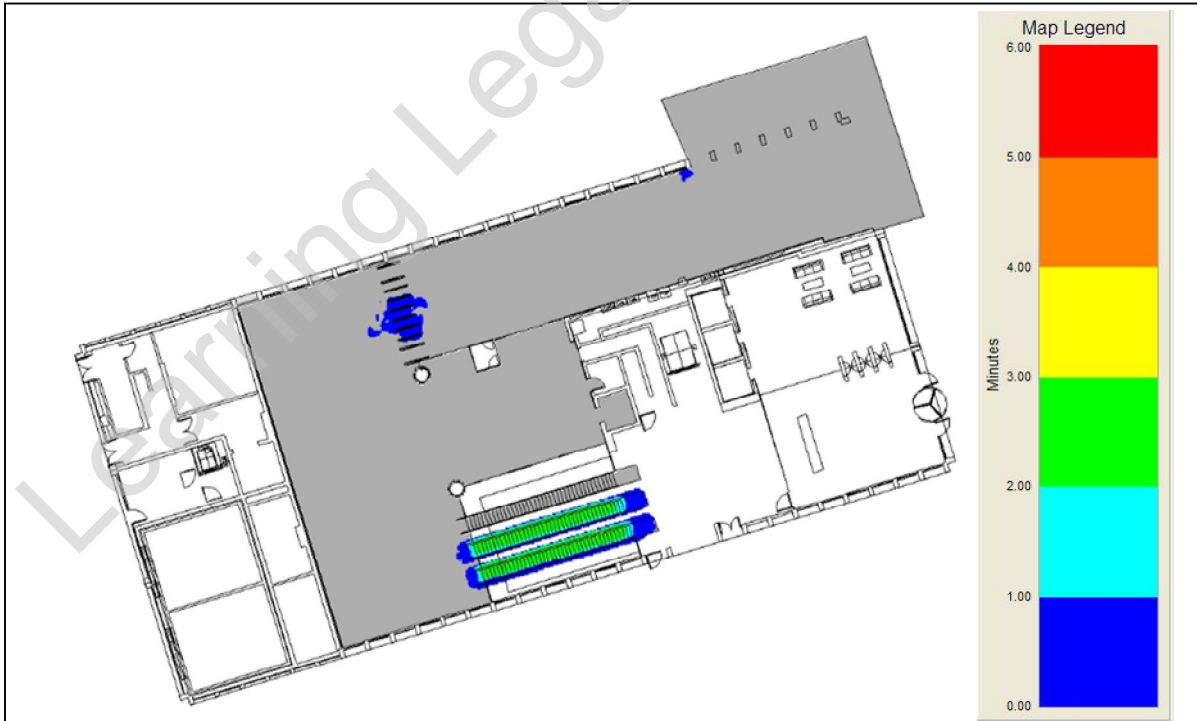
**AM Peak 2026+28% Stage E Design Davies Street Ticket Hall  
 Cumulative Mean Density Walking (8:45-9:00)**



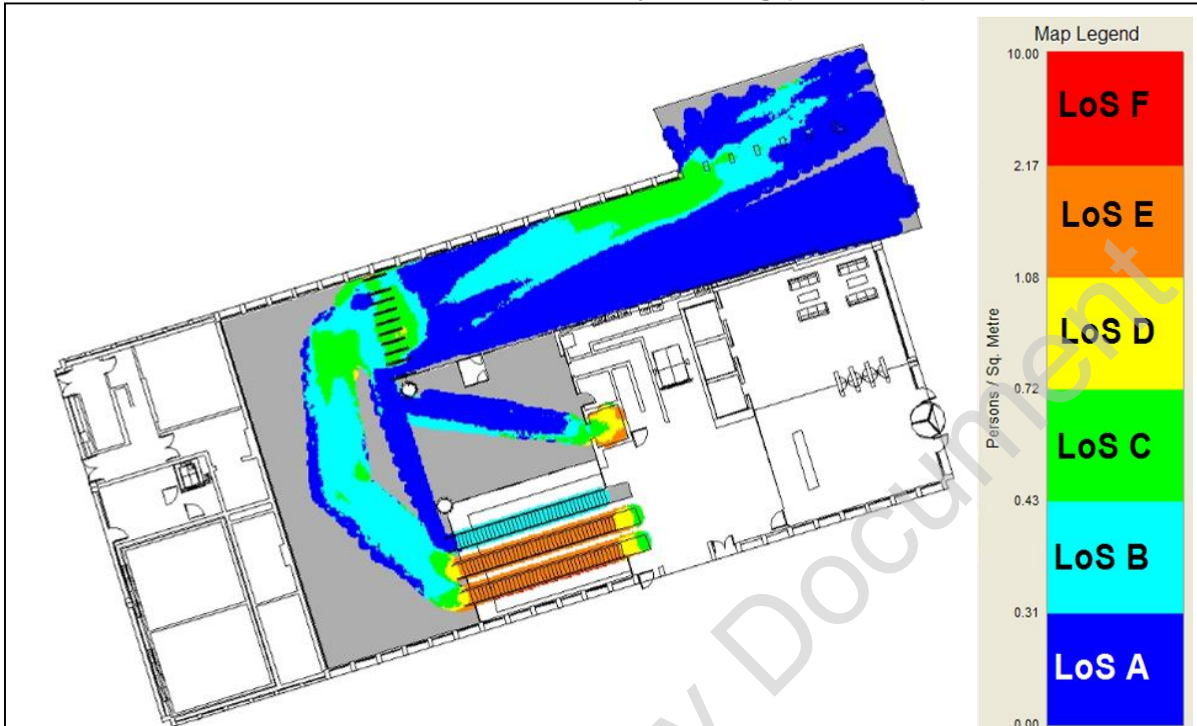
**AM Peak 2026+28% Stage E Design Davies Street Ticket Hall  
Cumulative Mean Density Queuing (8:45-9:00)**



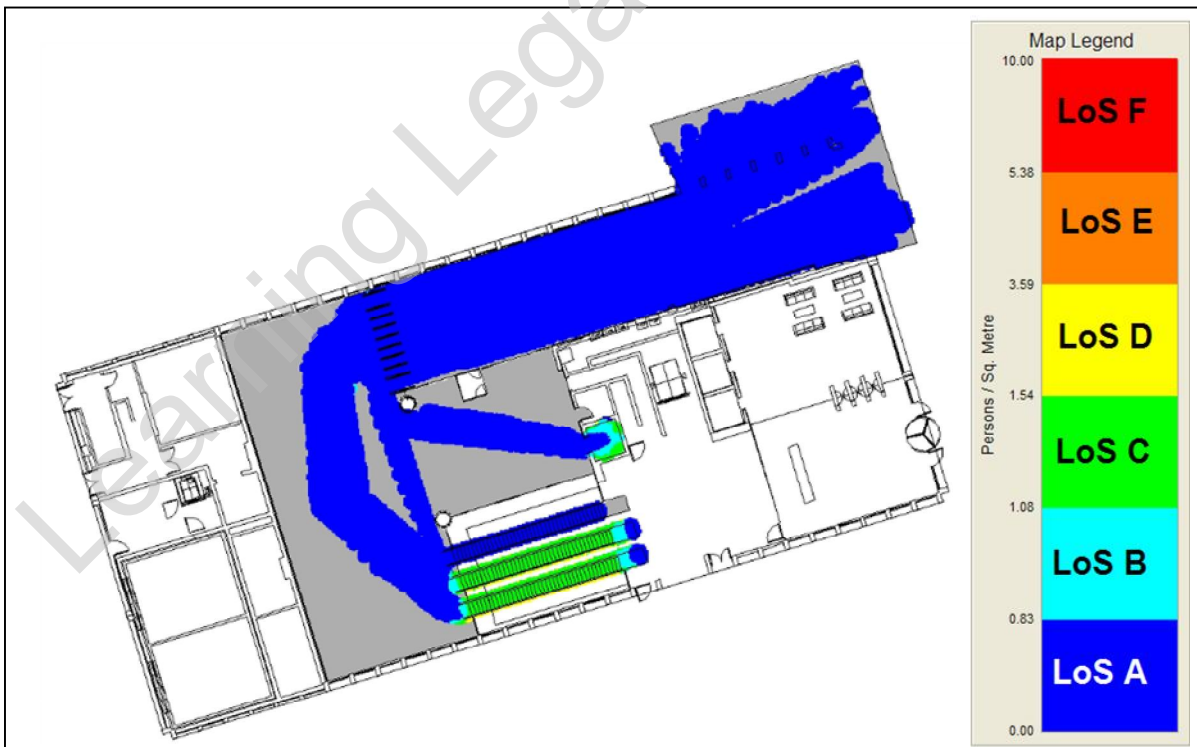
**AM Peak 2026+28% Stage E Design Davies Street Ticket Hall  
Cumulative High Density (8:45-9:00)**



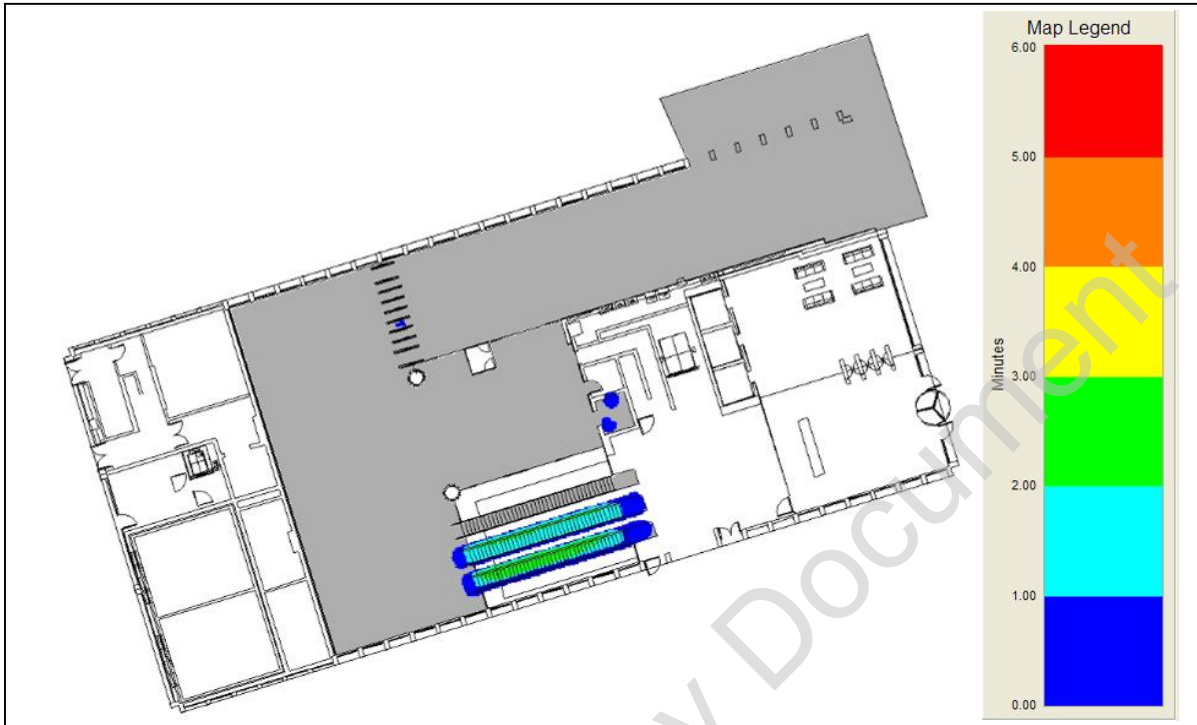
**AM Peak 2026+28% Stage E Design Davies Street Ticket Hall  
 Cumulative Mean Density Walking (9:00-9:15)**



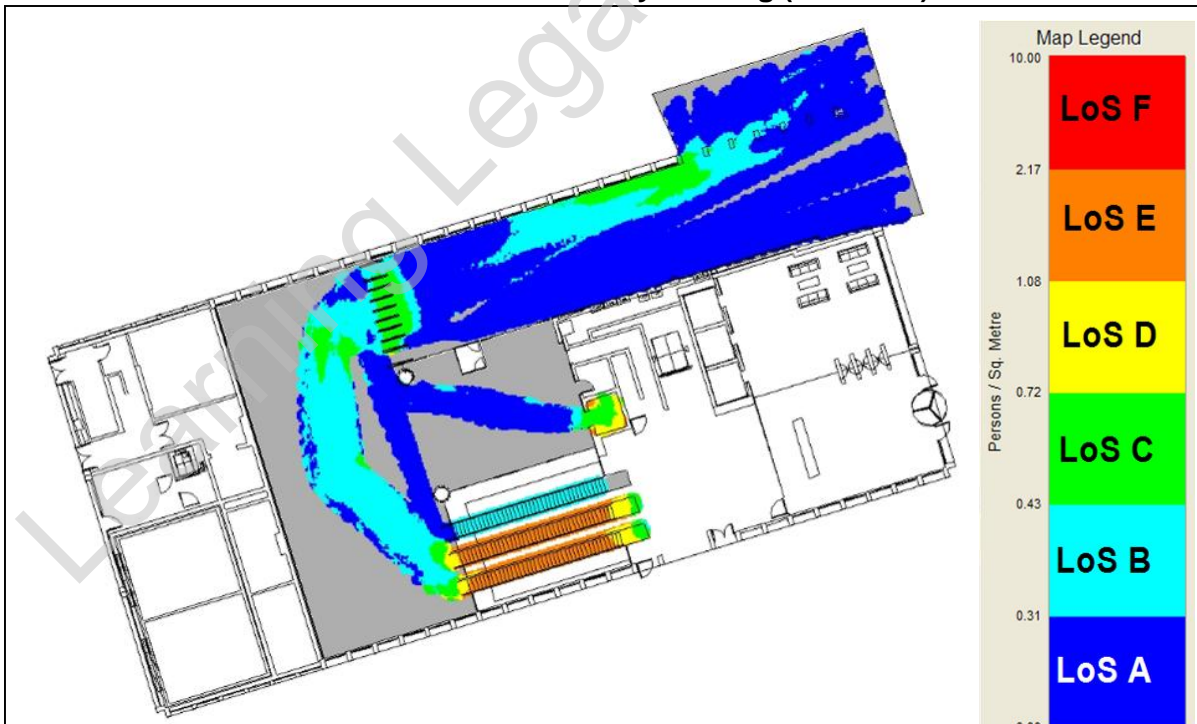
**AM Peak 2026+28% Stage E Design Davies Street Ticket Hall  
 Cumulative Mean Density Queuing (9:00-9:15)**



**AM Peak 2026+28% Stage E Design Davies Street Ticket Hall  
 Cumulative High Density (9:00-9:15)**



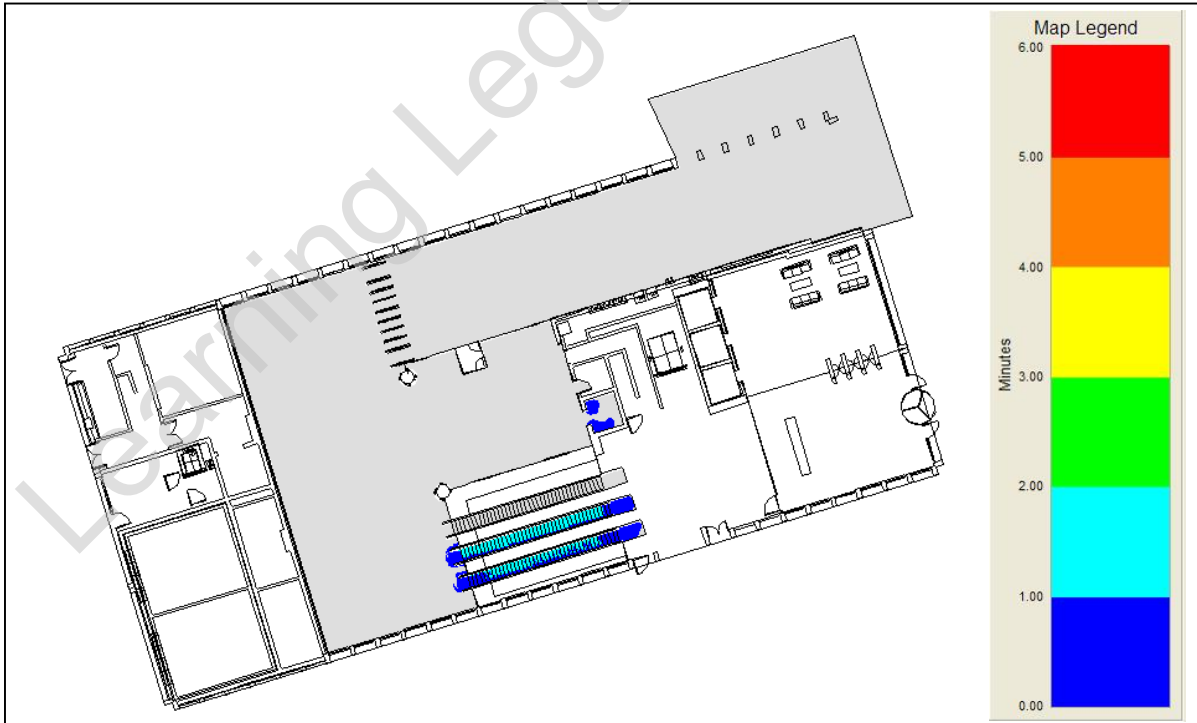
**AM Peak 2026+28% Stage E Design Davies Street Ticket Hall  
 Cumulative Mean Density Walking (9:15-9:30)**



**AM Peak 2026+28% Stage E Design Davies Street Ticket Hall  
 Cumulative Mean Density Queuing (9:15-9:30)**

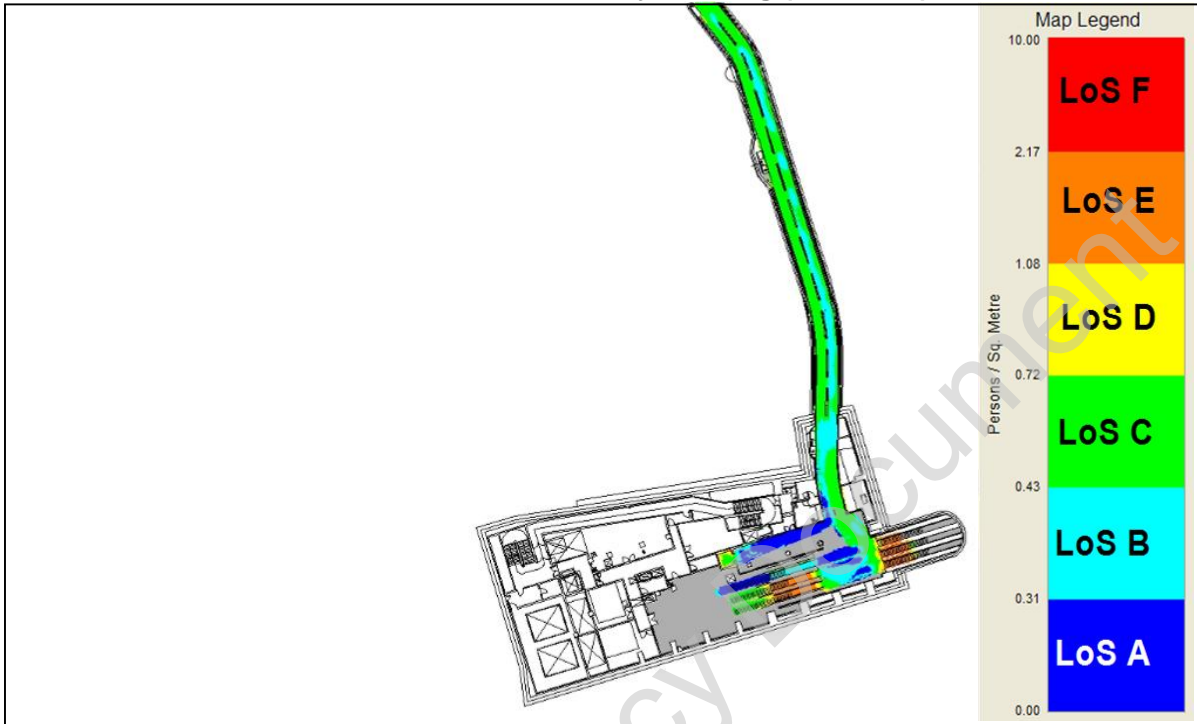


**AM Peak 2026+28% Stage E Design Davies Street Ticket Hall  
 Cumulative High (9:15-9:30)**

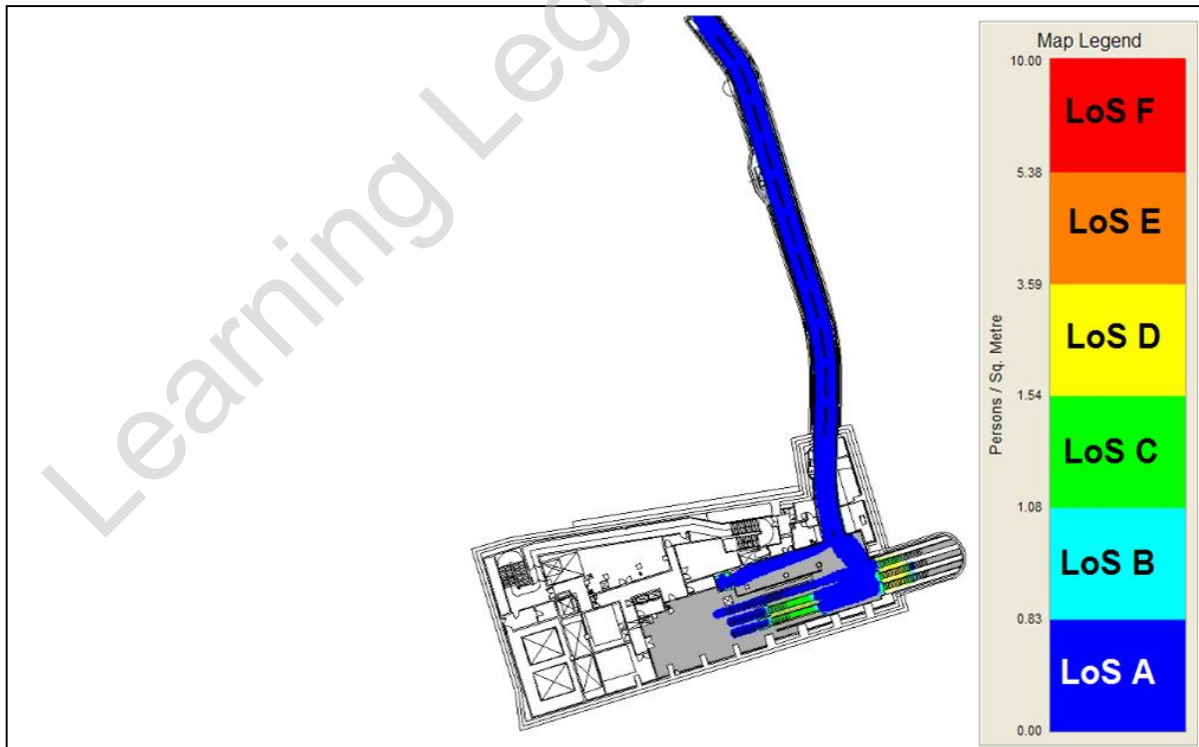


Intermediate Level

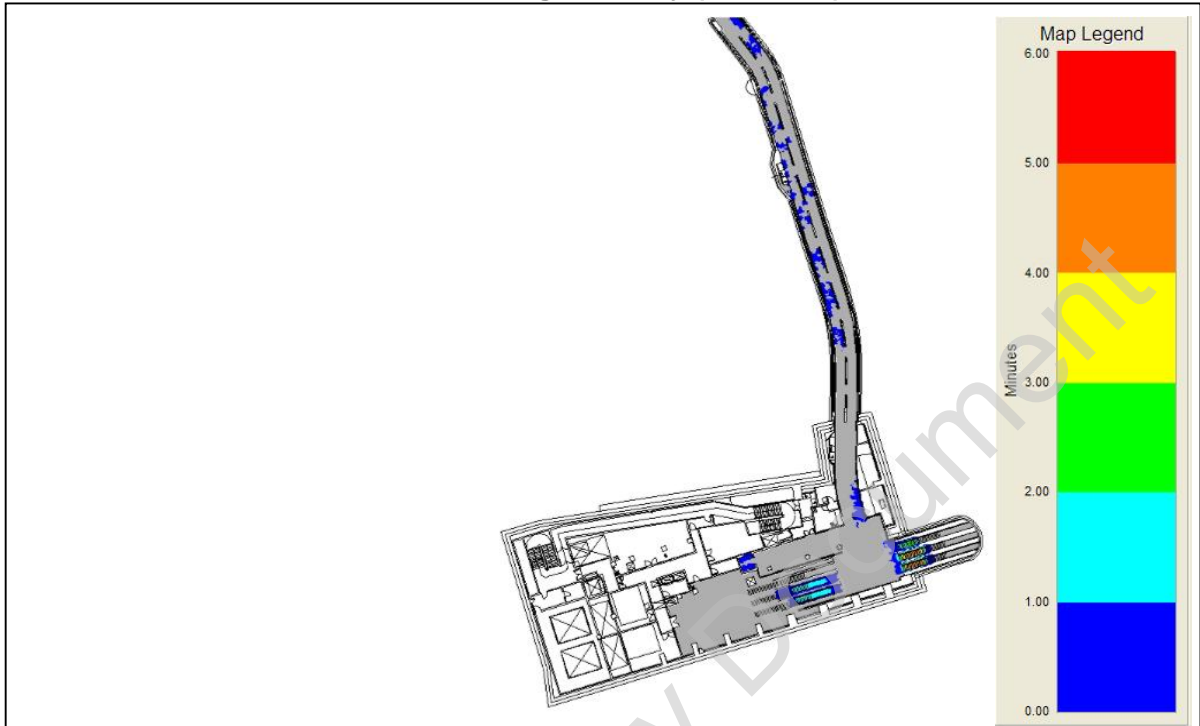
AM Peak 2026+28% Stage E Design Intermediate Level  
 Cumulative Mean Density Walking (8:30-8:45)



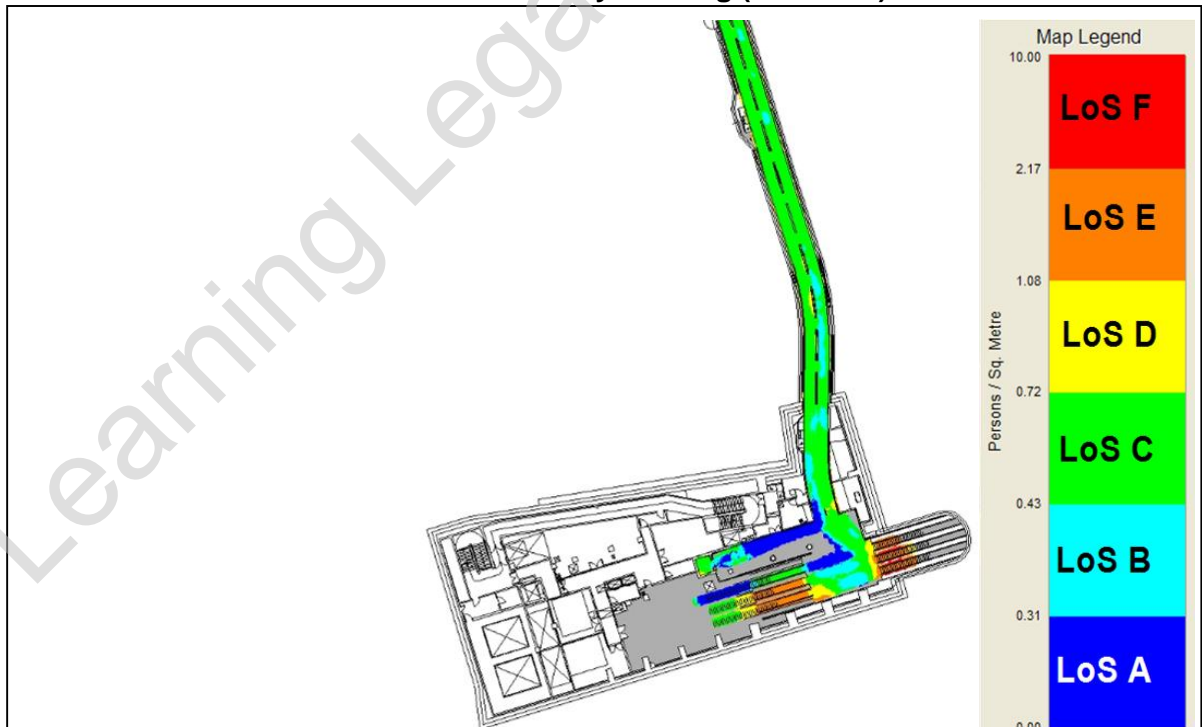
AM Peak 2026+28% Stage E Design Intermediate Level  
 Cumulative Mean Density Queuing (8:30-8:45)



**AM Peak 2026+28% Stage E Design Intermediate Level  
 Cumulative High Density (8:30-8:45)**

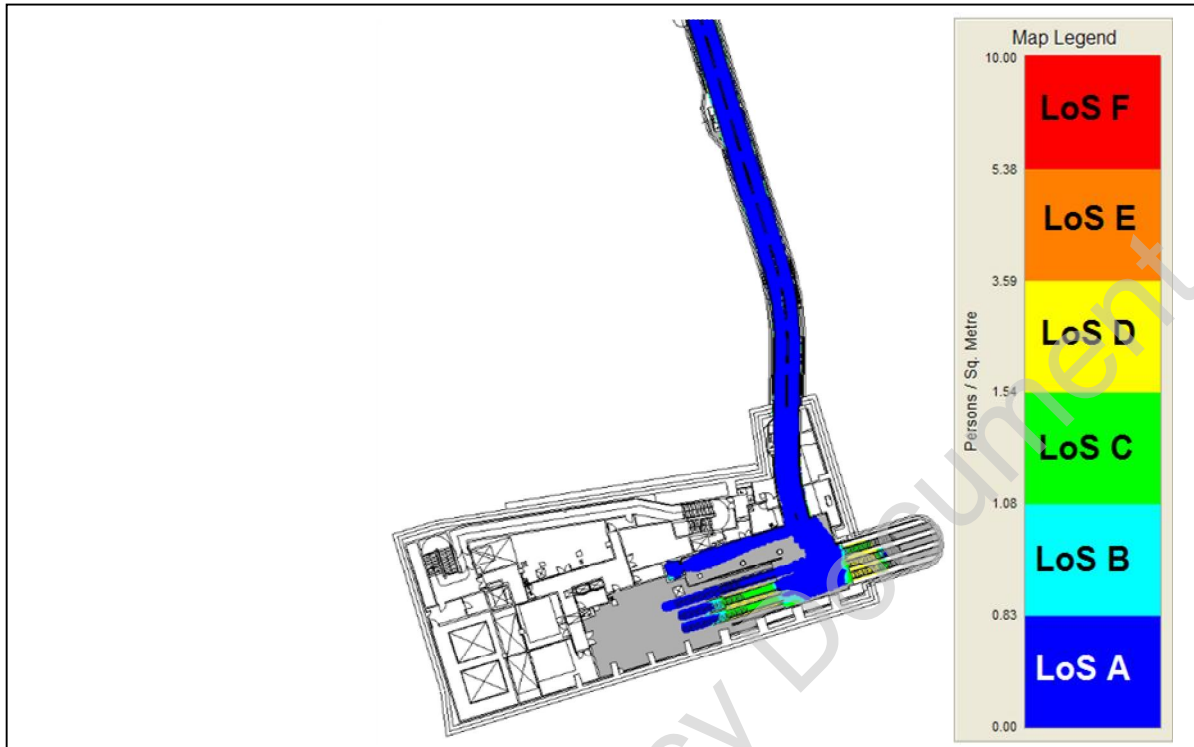


**AM Peak 2026+28% Stage E Design Intermediate Level  
 Cumulative Mean Density Walking (8:45-9:00)**

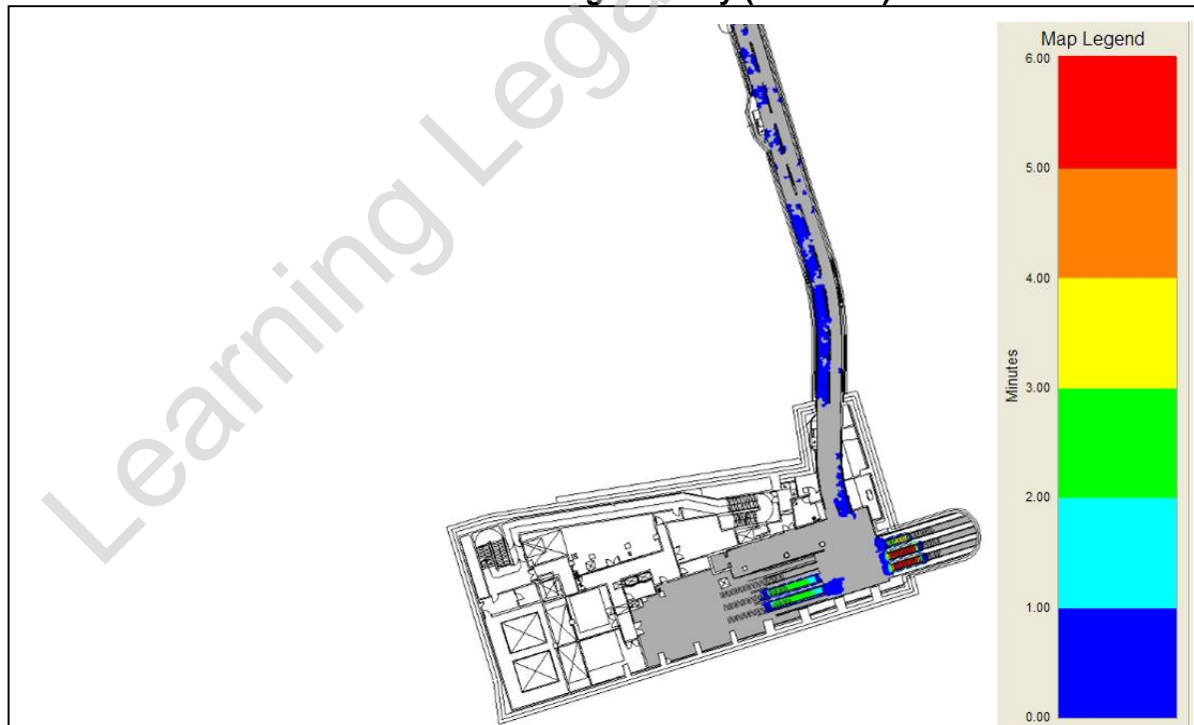




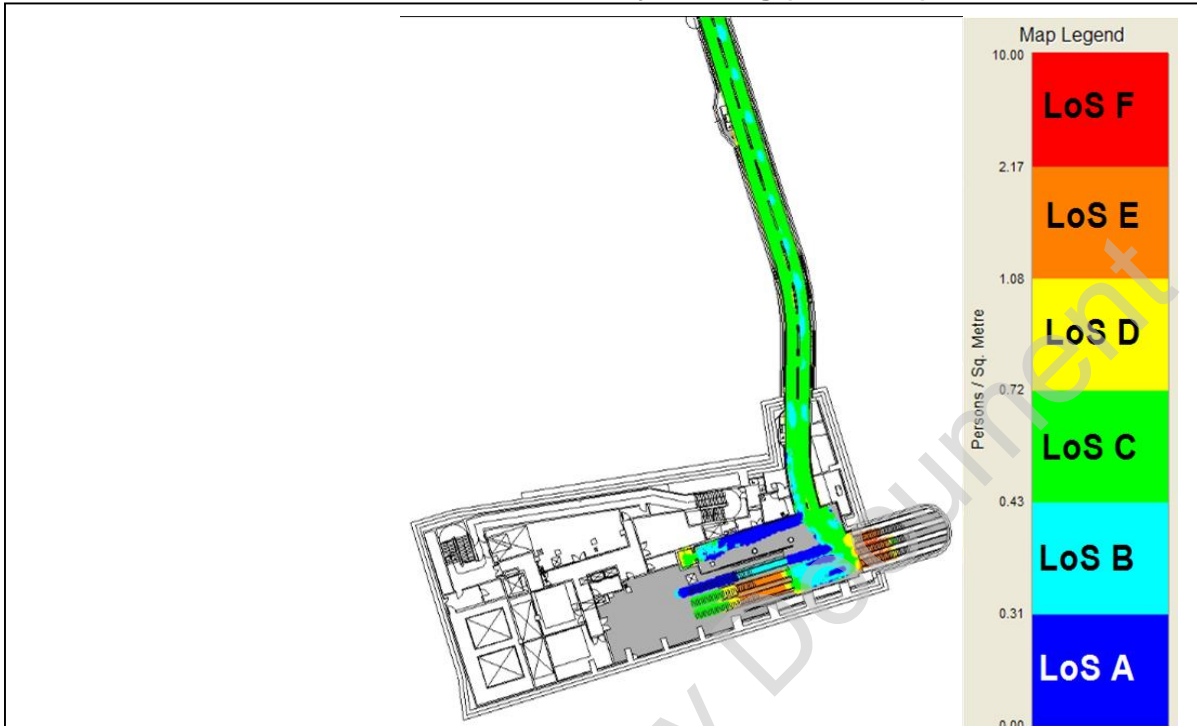
**AM Peak 2026+28% Stage E Design Intermediate Level  
 Cumulative Mean Density Queuing (8:45-9:00)**



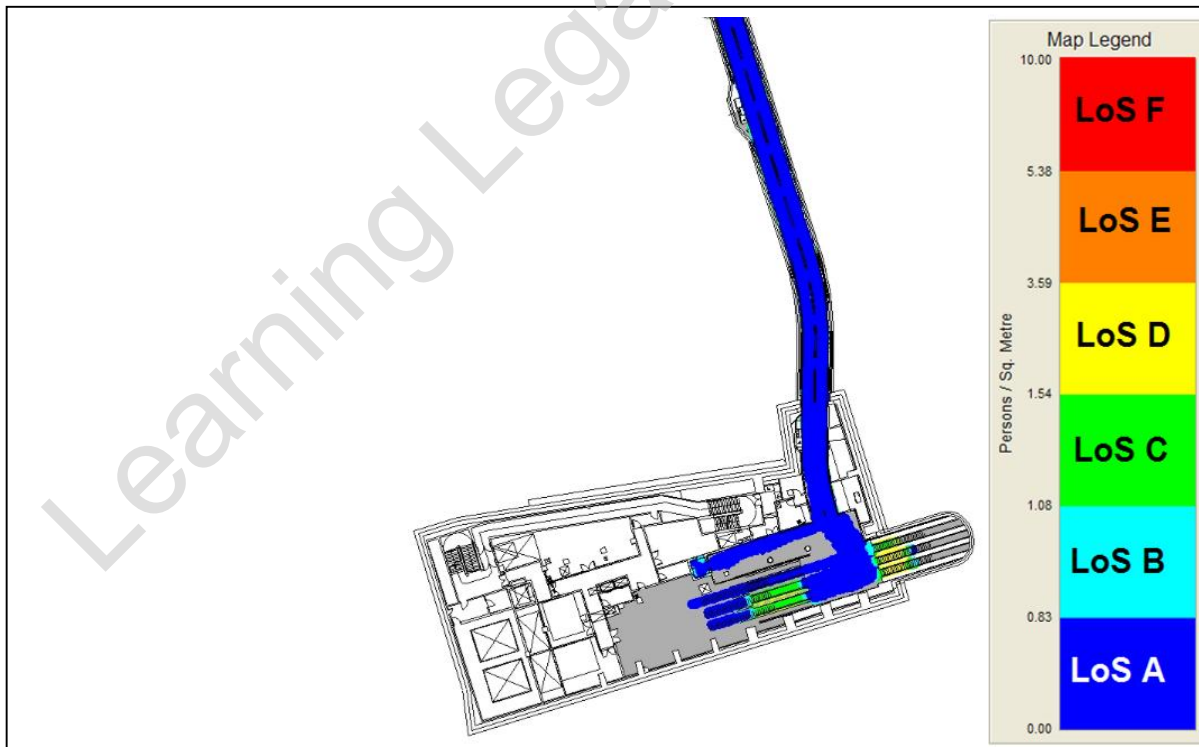
**AM Peak 2026+28% Stage E Design Intermediate Level  
 Cumulative High Density (8:45-9:00)**



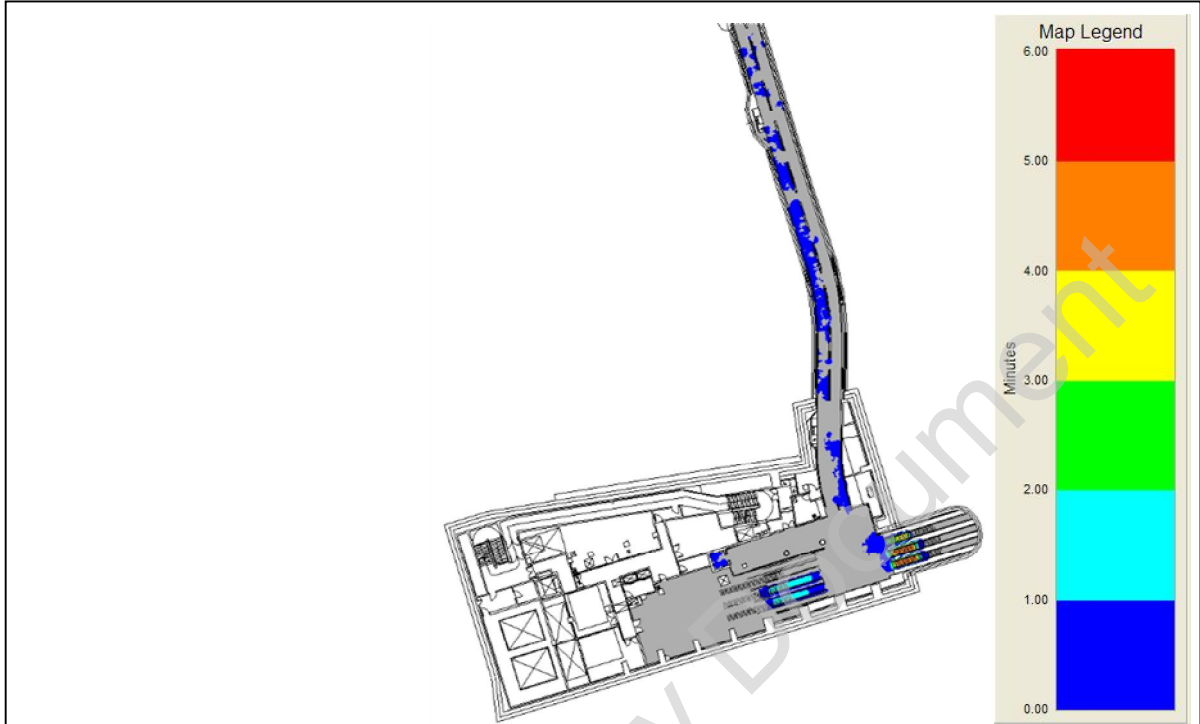
**AM Peak 2026+28% Stage E Design Intermediate Level  
 Cumulative Mean Density Walking (9:00-9:15)**



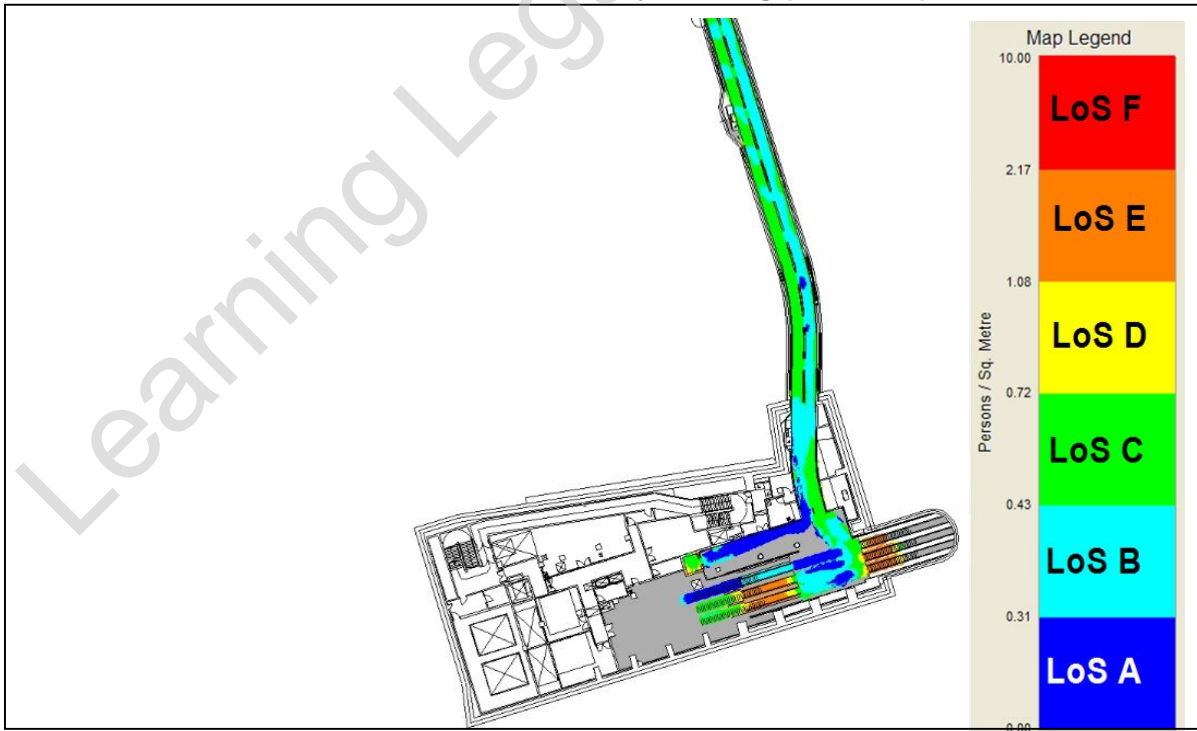
**AM Peak 2026+28% Stage E Design Intermediate Level  
 Cumulative Mean Density Queuing (9:00-9:15)**



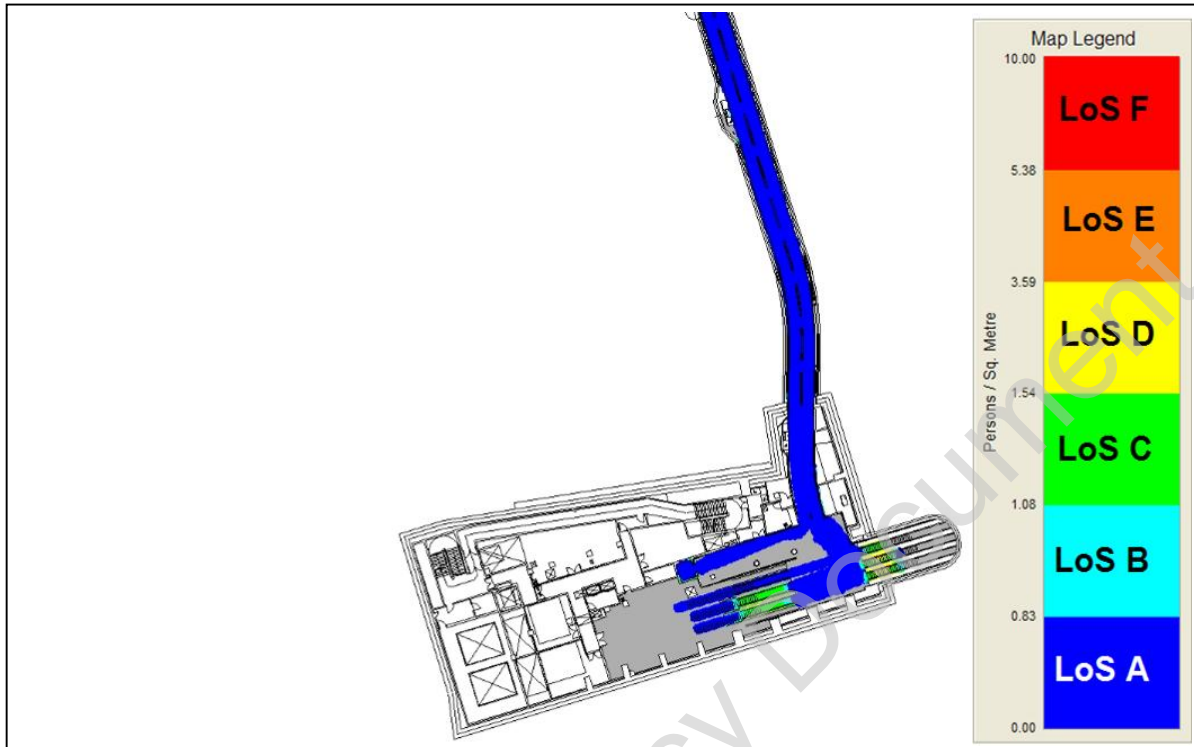
**AM Peak 2026+28% Stage E Design Intermediate Level  
 Cumulative High Density (9:00-9:15)**



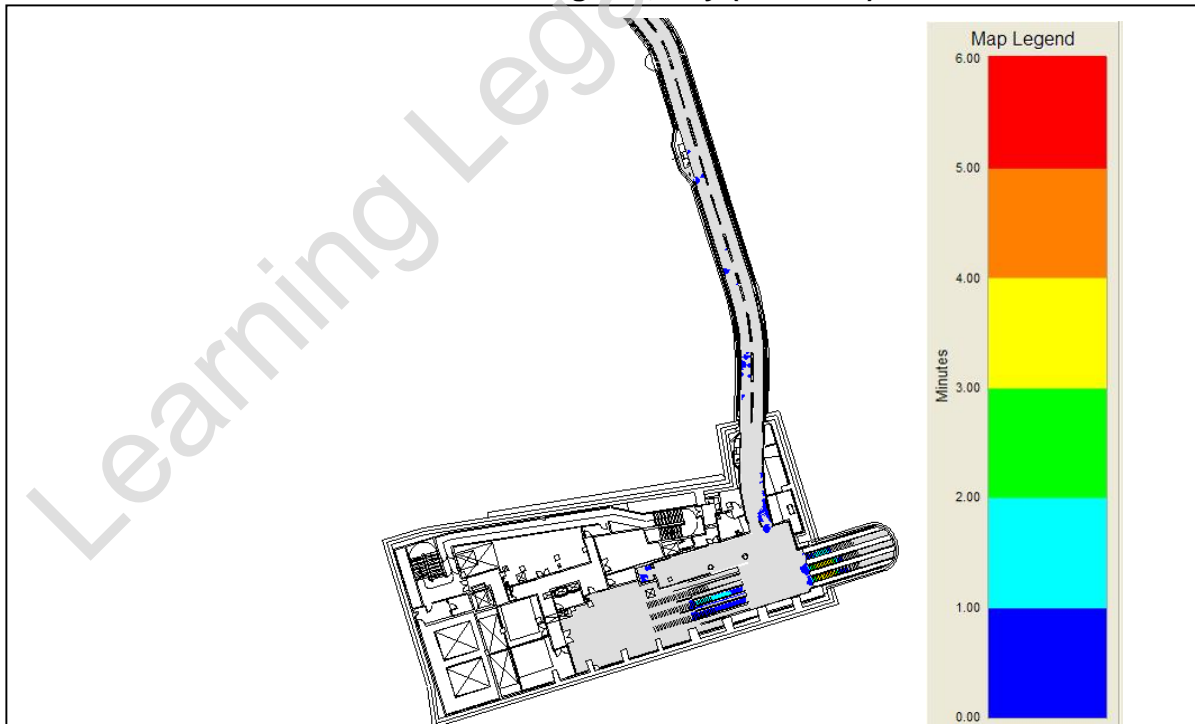
**AM Peak 2026+28% Stage E Design Intermediate Level  
 Cumulative Mean Density Walking (9:15-9:30)**



**AM Peak 2026+28% Stage E Design Intermediate Level  
 Cumulative Mean Density Queuing (9:15-9:30)**



**AM Peak 2026+28% Stage E Design Intermediate Level  
 Cumulative High Density (9:15-9:30)**

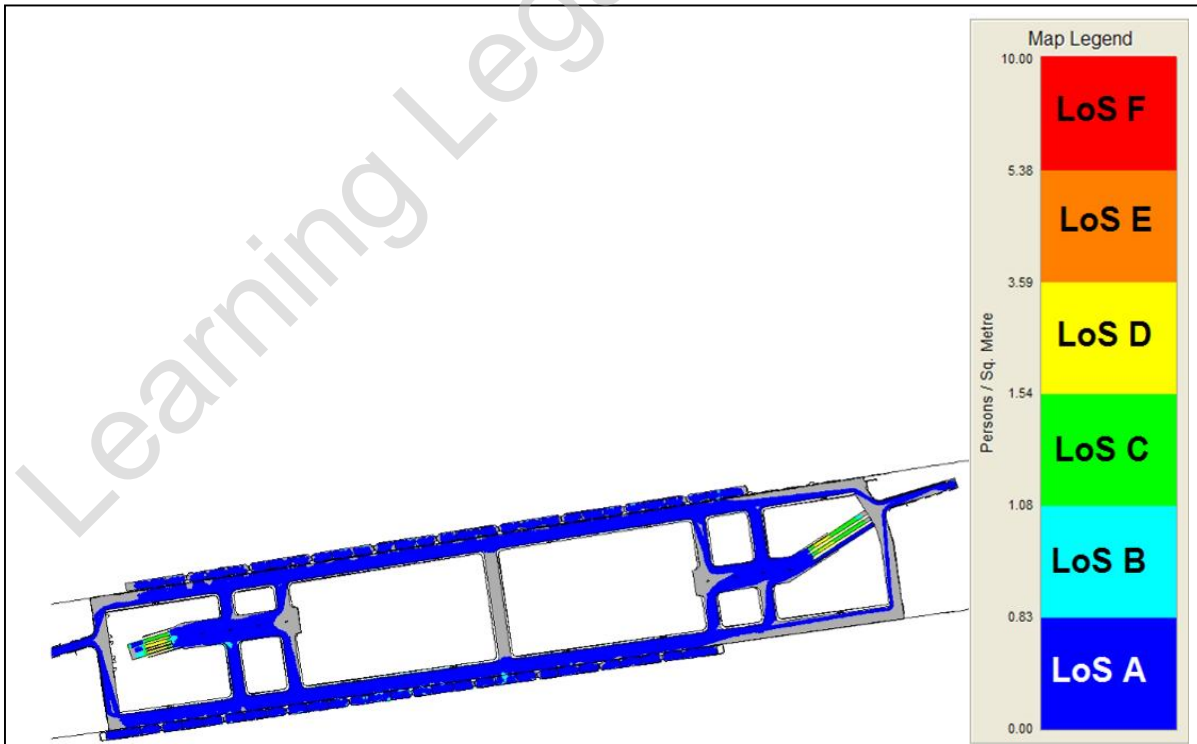


Platform Level

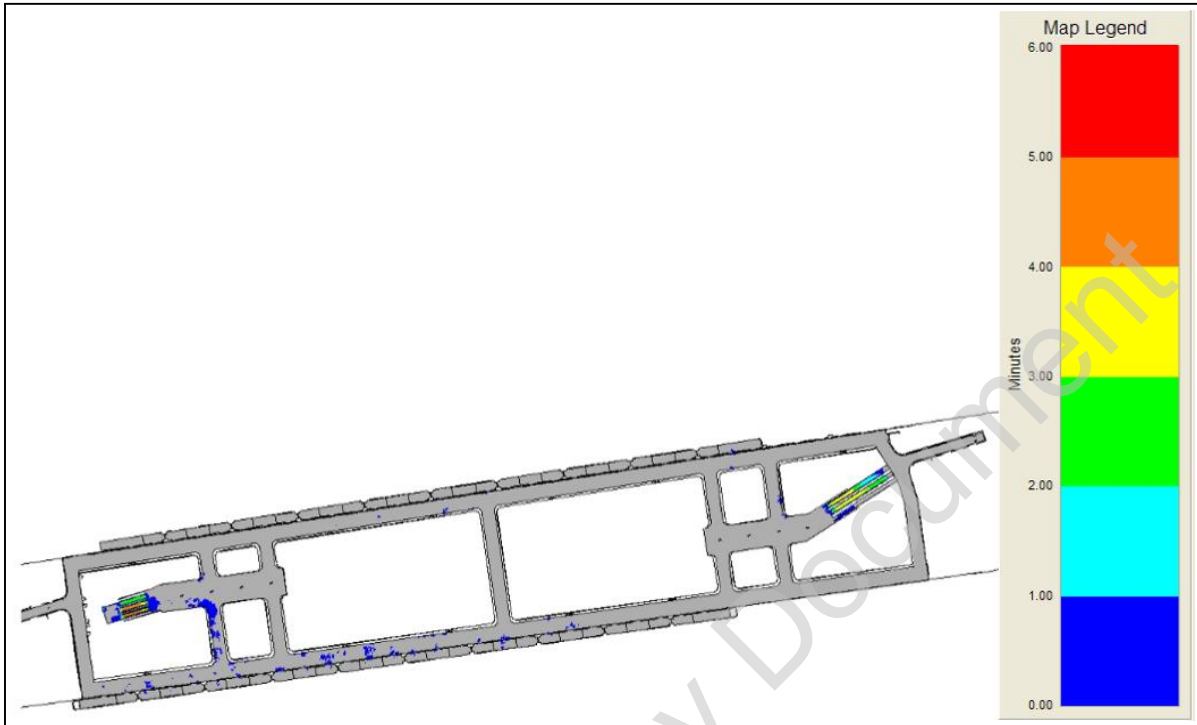
AM Peak 2026+28% Stage E Design Platform Level  
Cumulative Mean Density Walking (8:30-8:45)



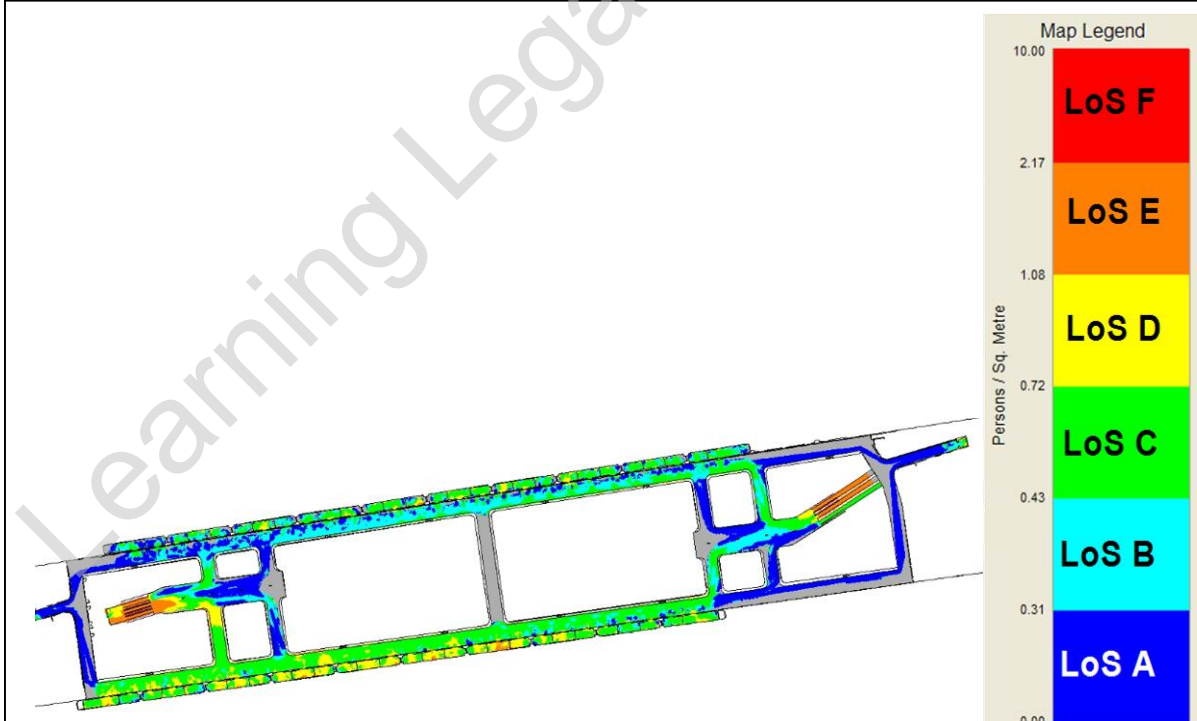
AM Peak 2026+28% Stage E Design Platform Level  
Cumulative Mean Density Queuing (8:30-8:45)



**AM Peak 2026+28% Stage E Design Platform Level  
 Cumulative High Density (8:30-8:45)**



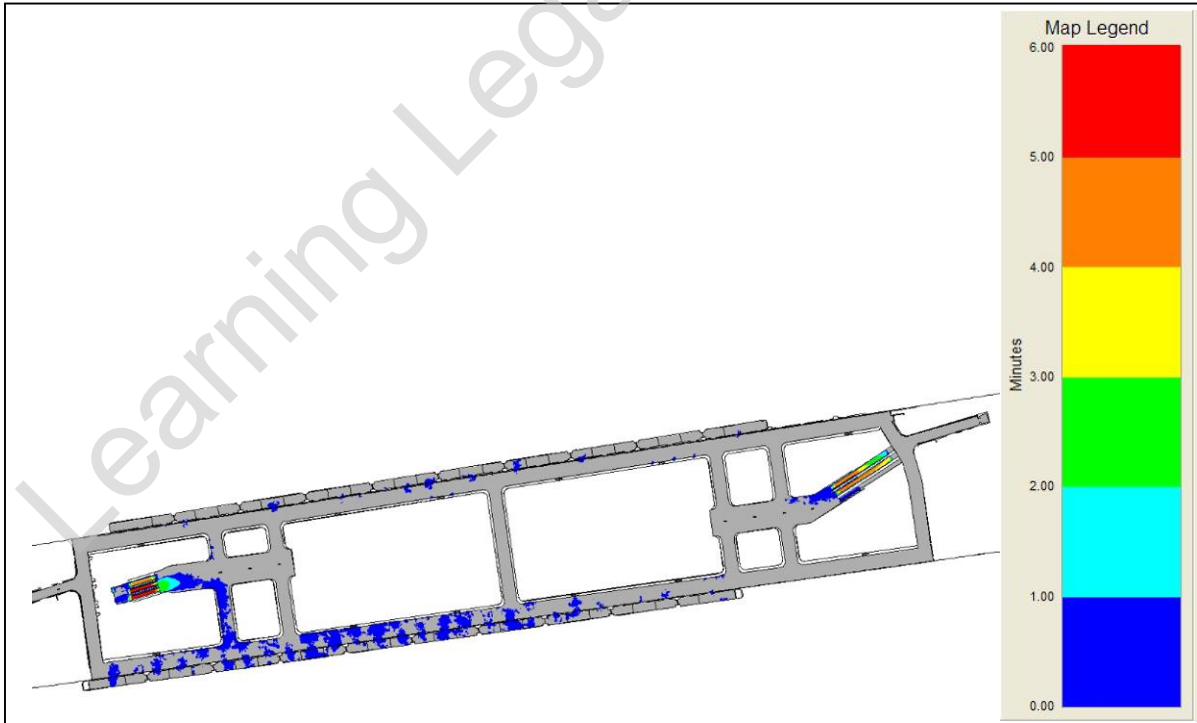
**AM Peak 2026+28% Stage E Design Platform Level  
 Cumulative Mean Density Walking (8:45-9:00)**



**AM Peak 2026+28% Stage E Design Platform Level  
 Cumulative Mean Density Queuing (8:45-9:00)**



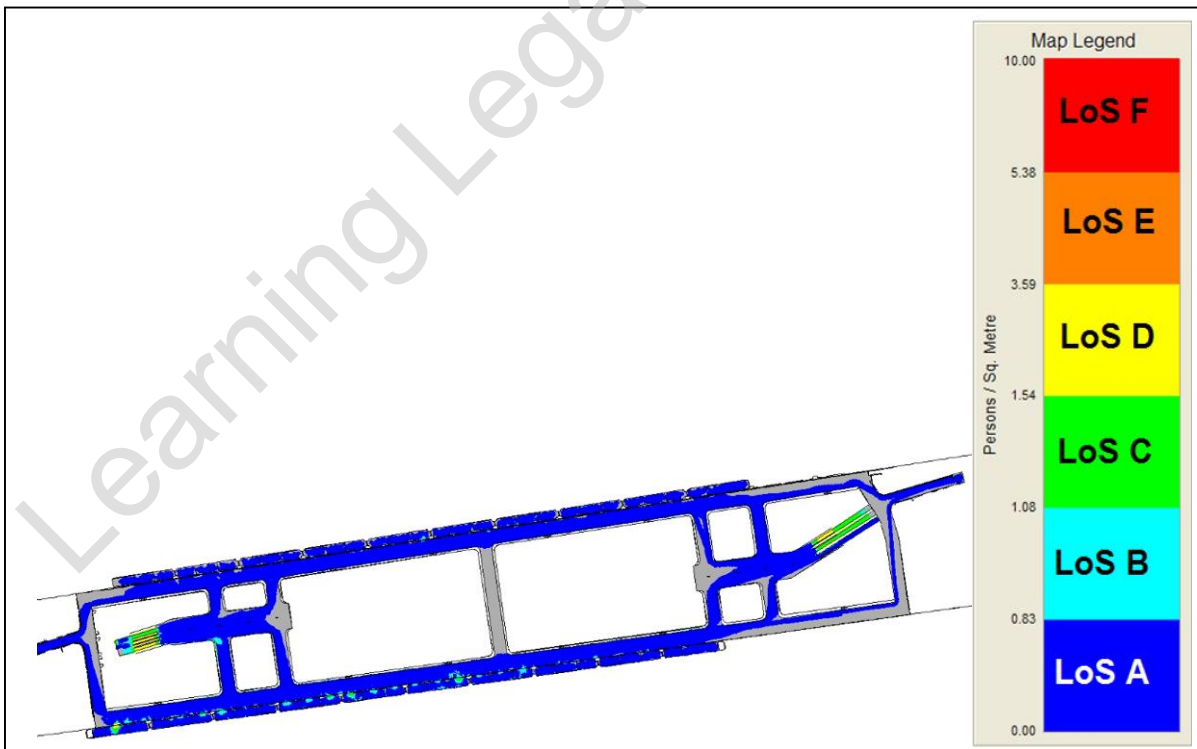
**AM Peak 2026+28% Stage E Design Platform Level  
 Cumulative High Density (8:45-9:00)**



**AM Peak 2026+28% Stage E Design Platform Level  
 Cumulative Mean Density Walking (9:00-9:15)**

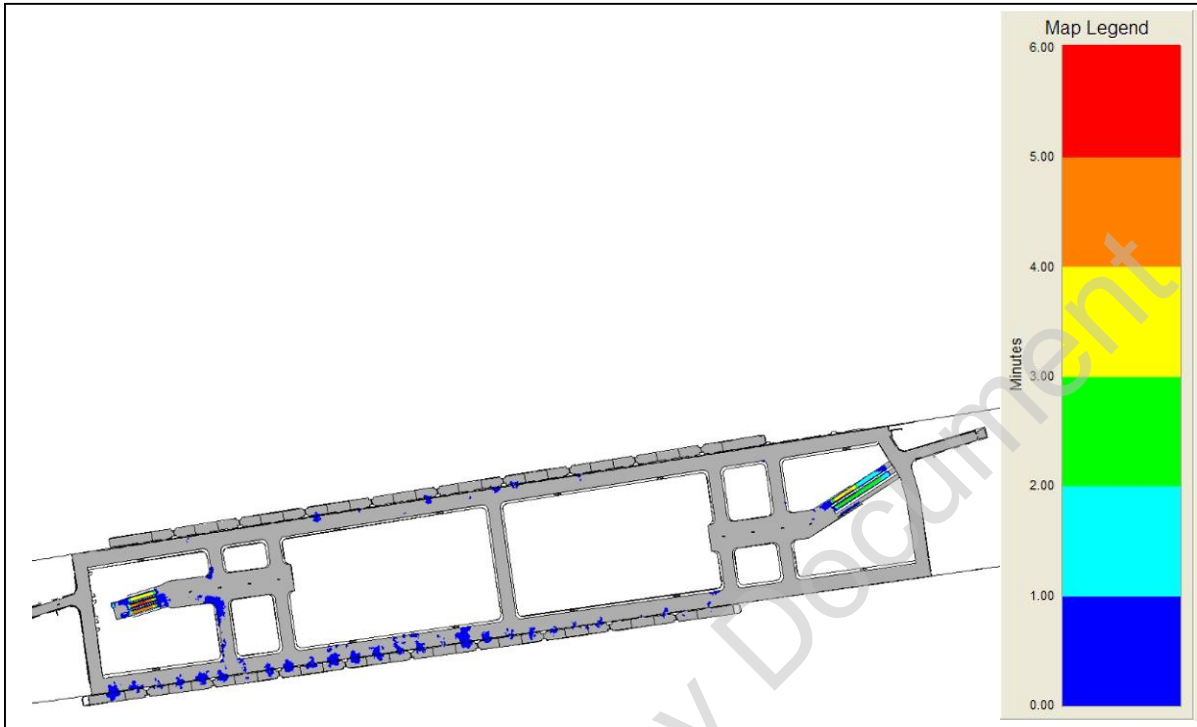


**AM Peak 2026+28% Stage E Design Platform Level  
 Cumulative Mean Density Queuing (9:00-9:15)**

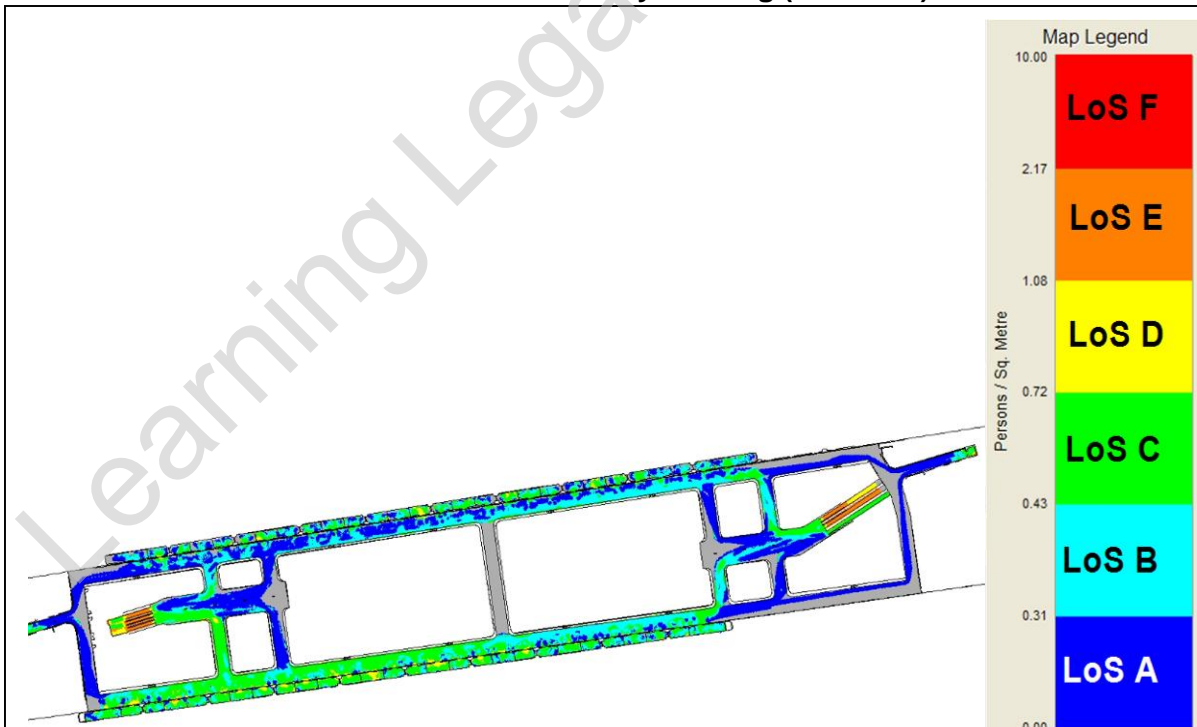




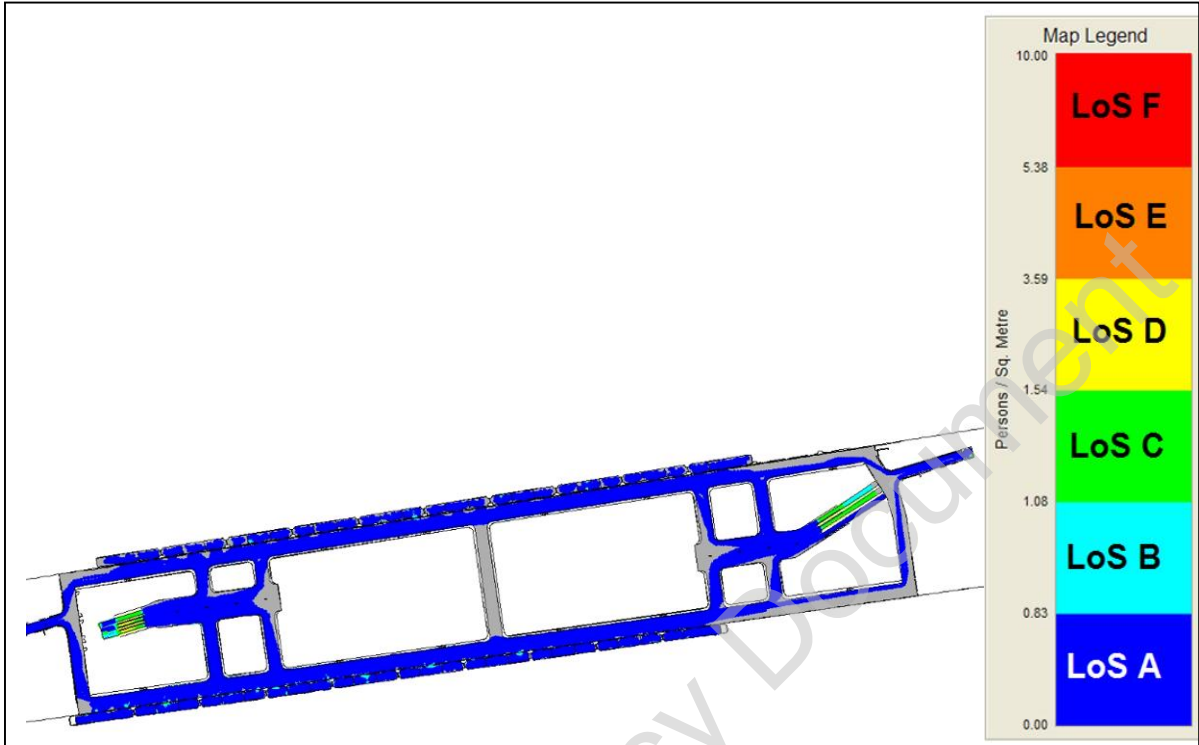
**AM Peak 2026+28% Stage E Design Platform Level  
 Cumulative High Density (9:00-9:15)**



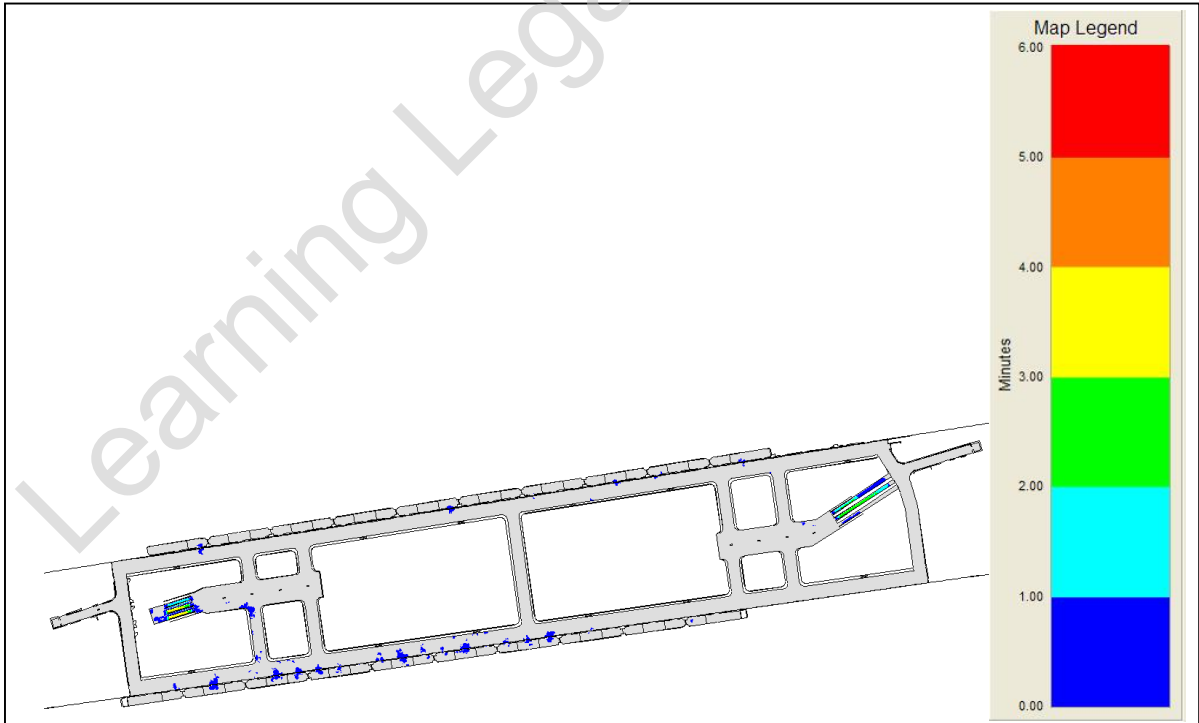
**AM Peak 2026+28% Stage E Design Platform Level  
 Cumulative Mean Density Walking (9:15-9:30)**



**AM Peak 2026+28% Stage E Design Platform Level  
 Cumulative Mean Density Queuing (9:15-9:30)**



**AM Peak 2026+28% Stage E Design Platform Level  
 Cumulative High (9:15-9:30)**



## Appendix G – PM 2026 Density Maps

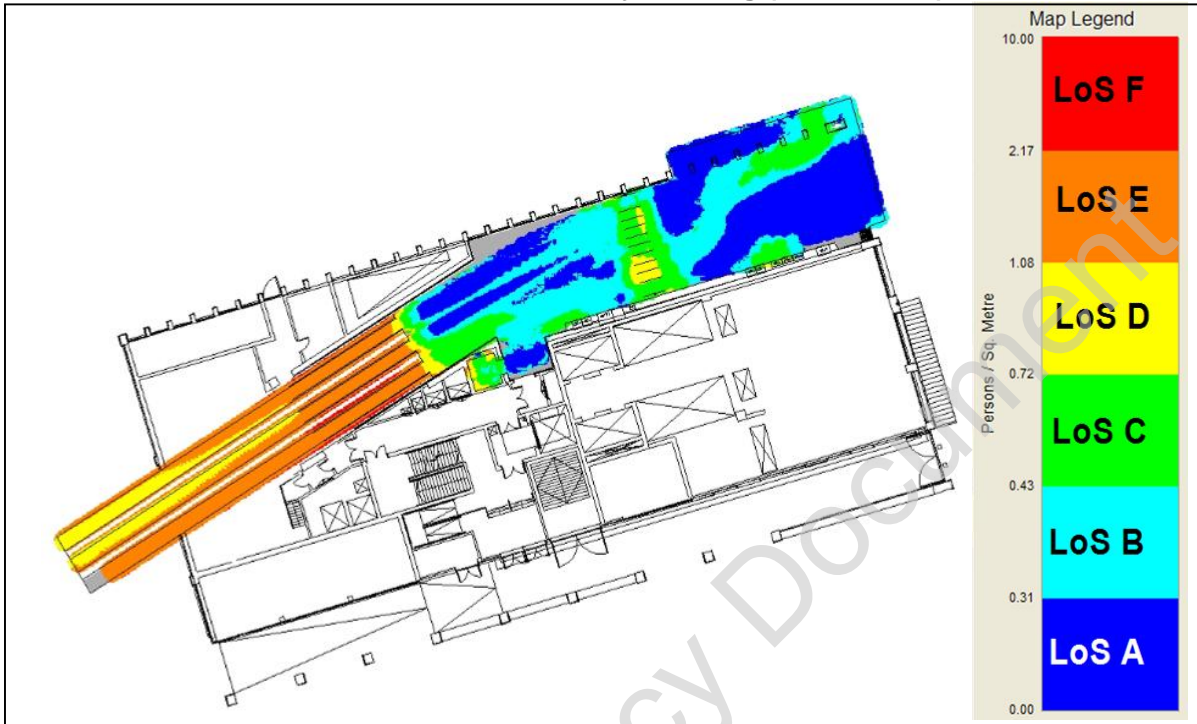
Cumulative Mean Density (CMD) maps provide the average density conditions that occur within the peak 15 minutes these are presented in 15 minute segments for the peak hour (17:30-18:30).

Cumulative High Density Maps (CHD) maps shows how long various areas of a site have registered densities greater than 1.54 passengers/sq.metre. The range of colours represent time, in 1 minute intervals (up to 6 minutes). The map is similar to a 'temperature' map: areas that have experienced high levels of density for a long time appear red; those that have experienced shorter periods of density appear blue.

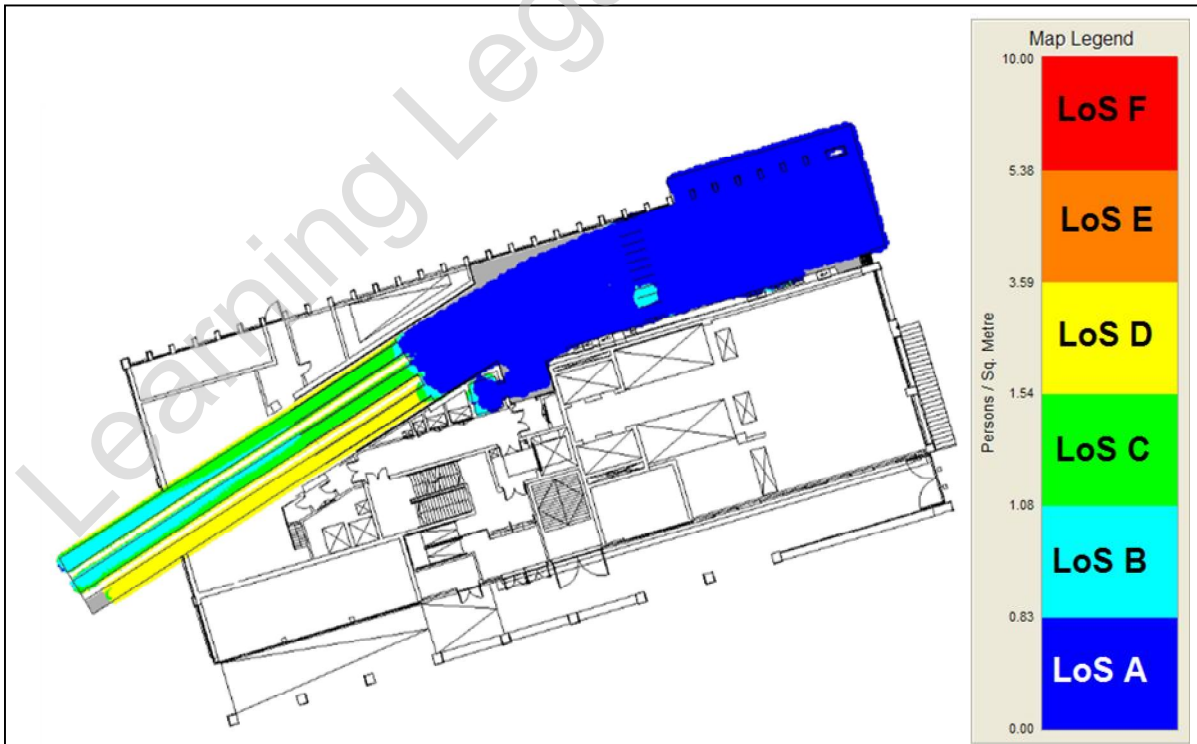
Learning Legacy Document

Hanover Square Ticket Hall

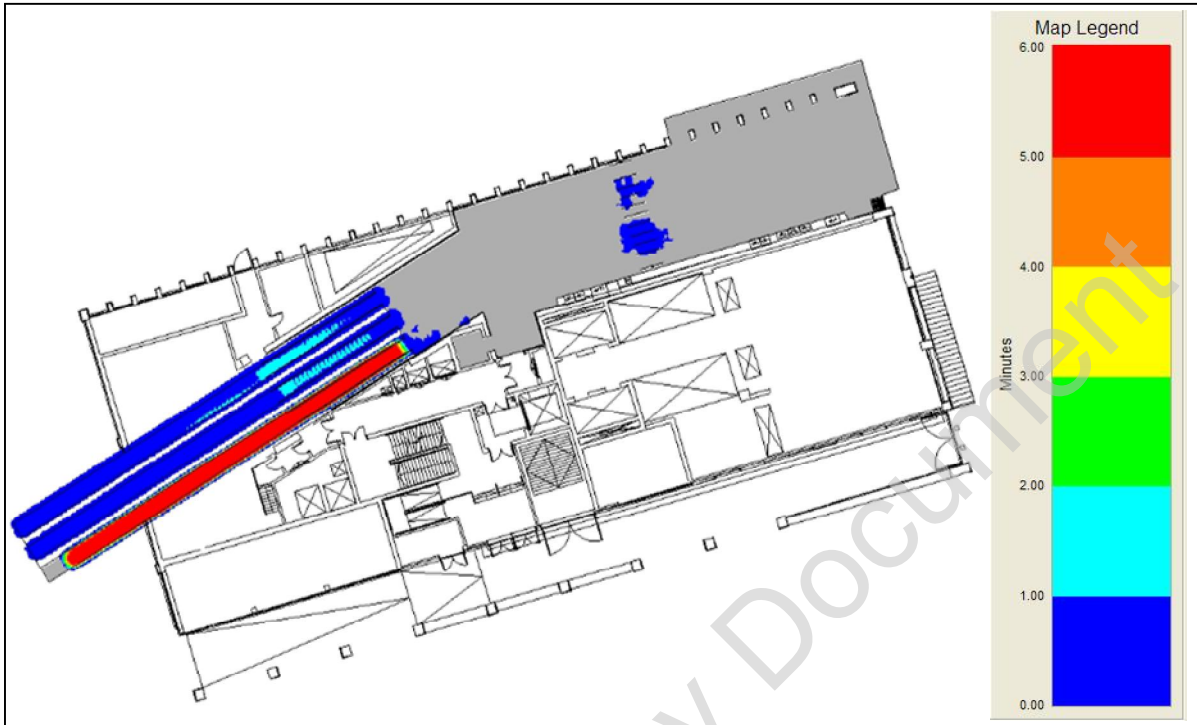
PM Peak 2026 Stage E Design Hanover Square Ticket Hall  
 Cumulative Mean Density Walking (17:30-17:45)



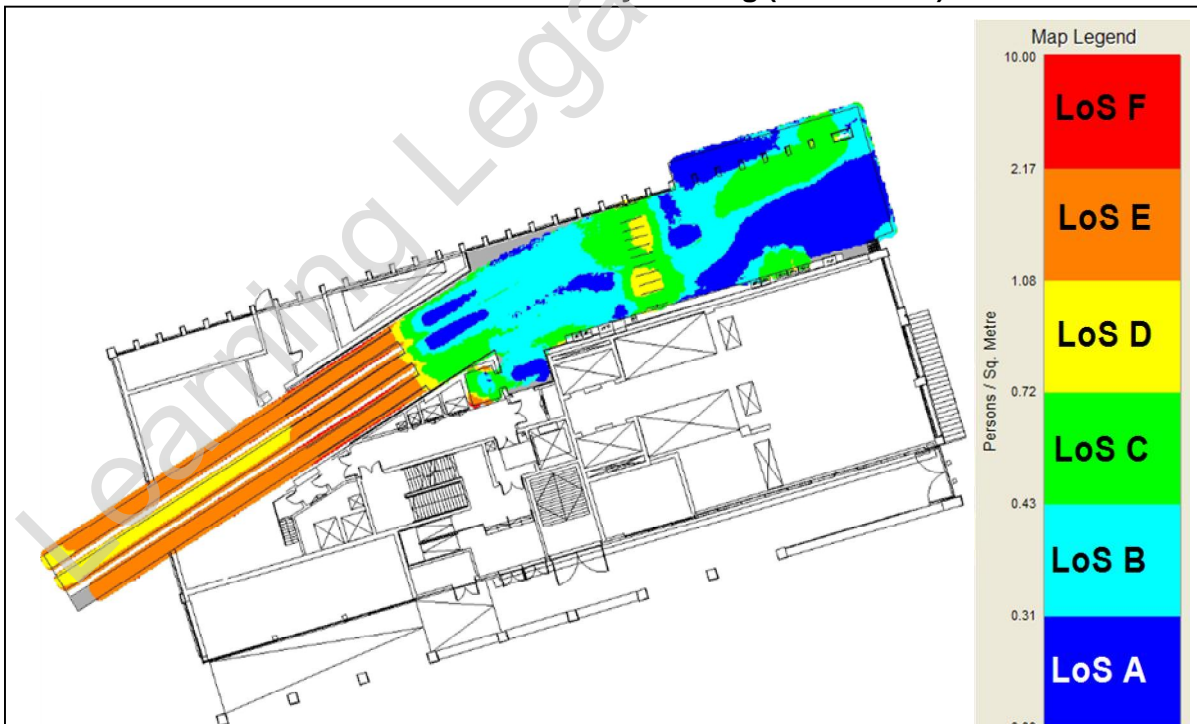
PM Peak 2026 Stage E Design Hanover Square Ticket Hall  
 Cumulative Mean Density Queuing (17:30-17:45)



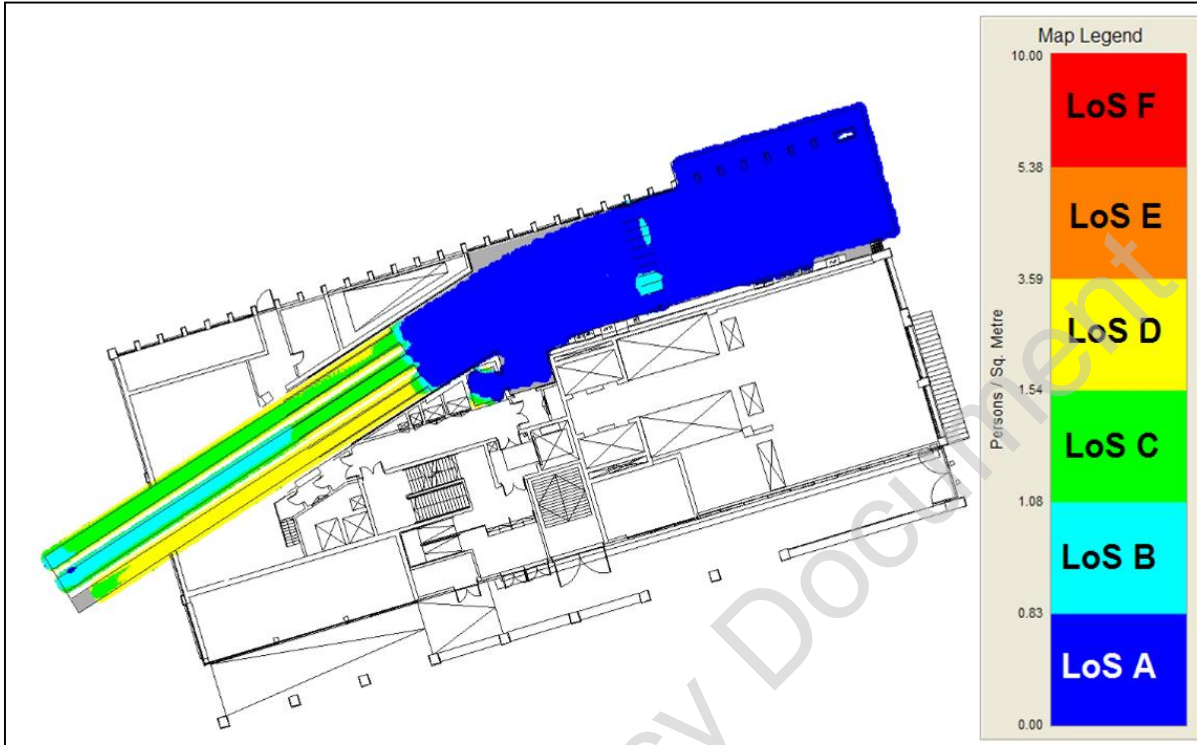
**PM Peak 2026 Stage E Design Hanover Square Ticket Hall  
Cumulative High Density (17:30-17:45)**



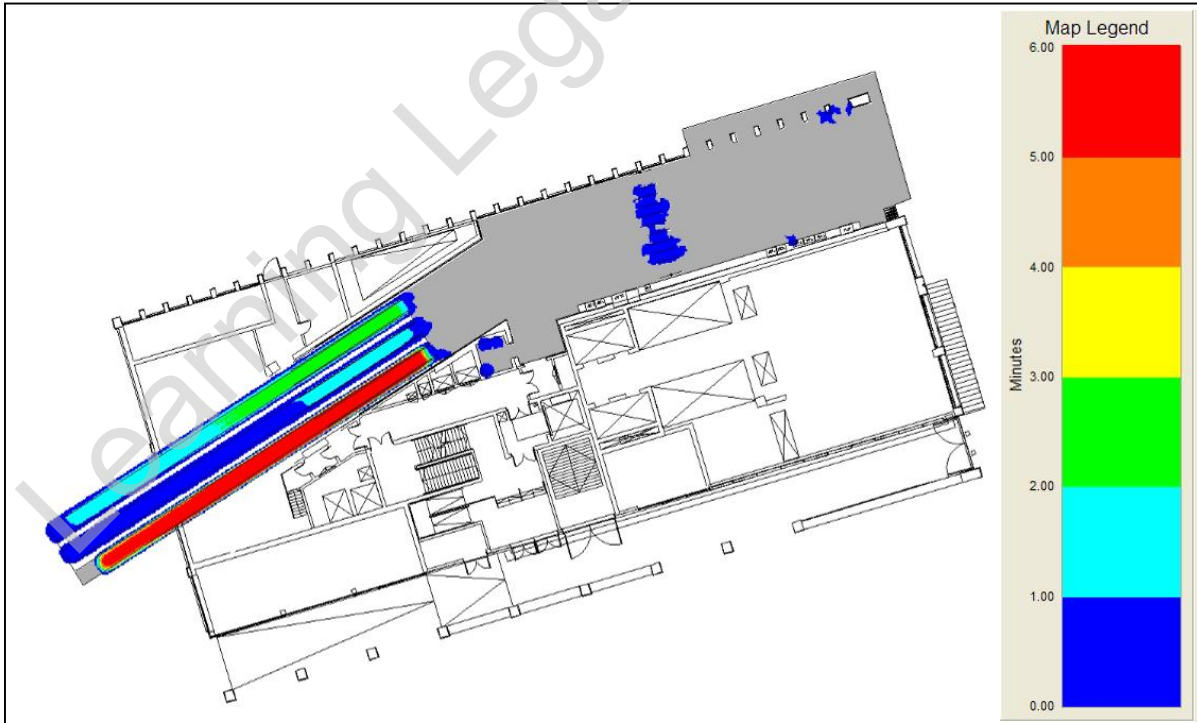
**PM Peak 2026 Stage E Design Hanover Square Ticket Hall  
Cumulative Mean Density Walking (17:45-18:00)**



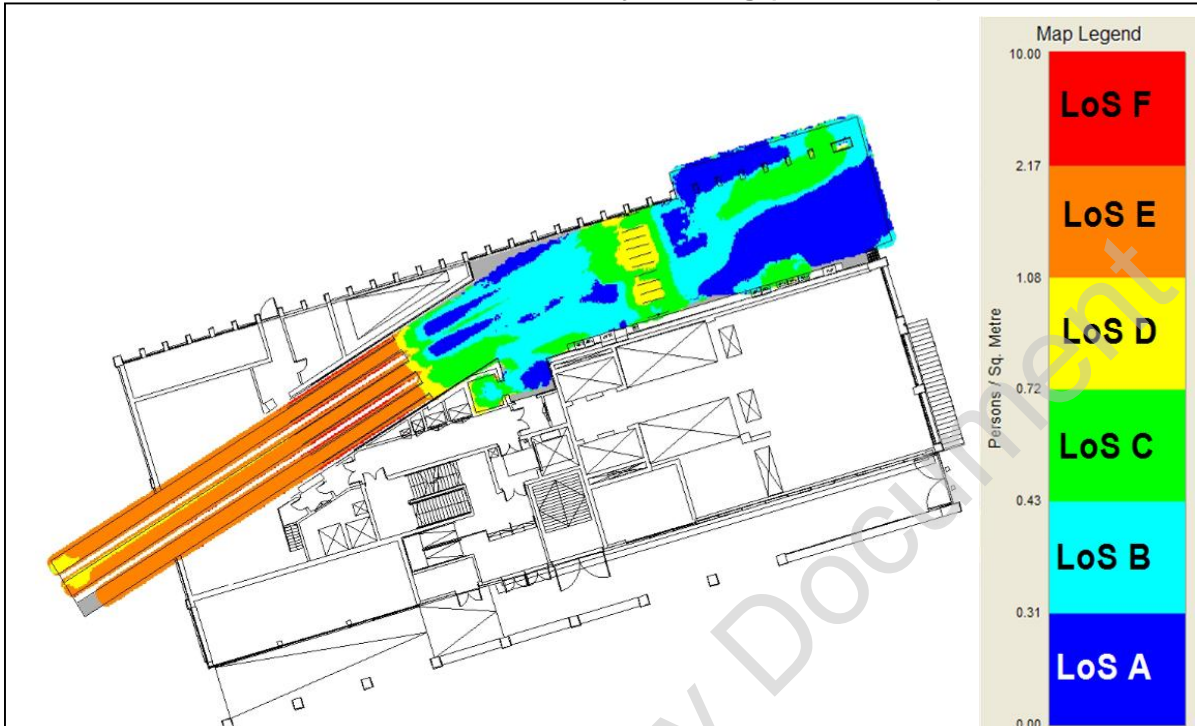
**PM Peak 2026 Stage E Design Hanover Square Ticket Hall  
 Cumulative Mean Density Queuing (17:45-18:00)**



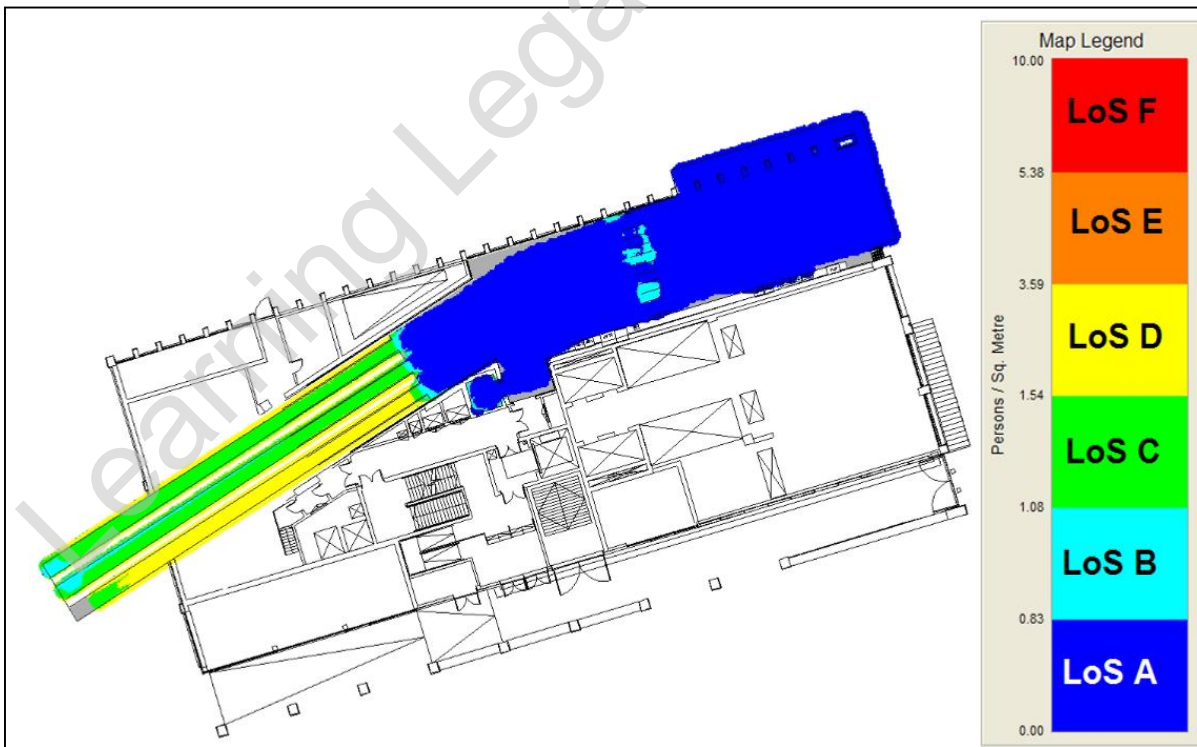
**PM Peak 2026 Stage E Design Hanover Square Ticket Hall  
 Cumulative High Density (17:45-18:00)**



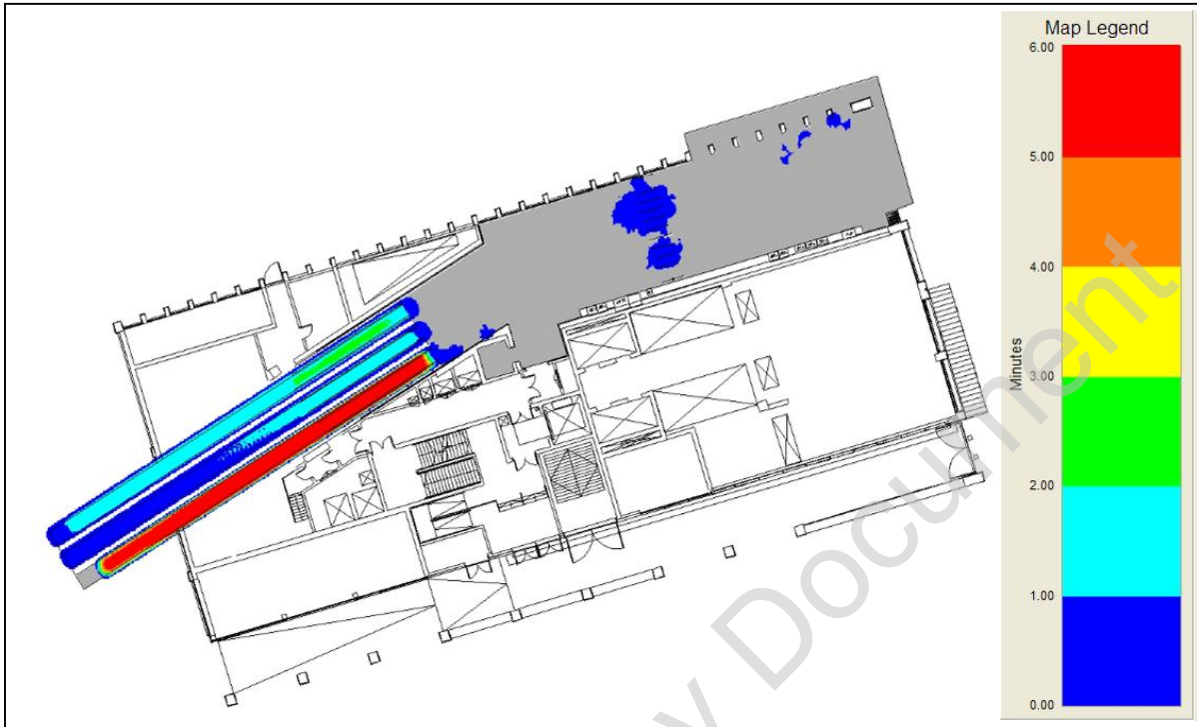
**PM Peak 2026 Stage E Design Hanover Square Ticket Hall  
 Cumulative Mean Density Walking (18:00-18:15)**



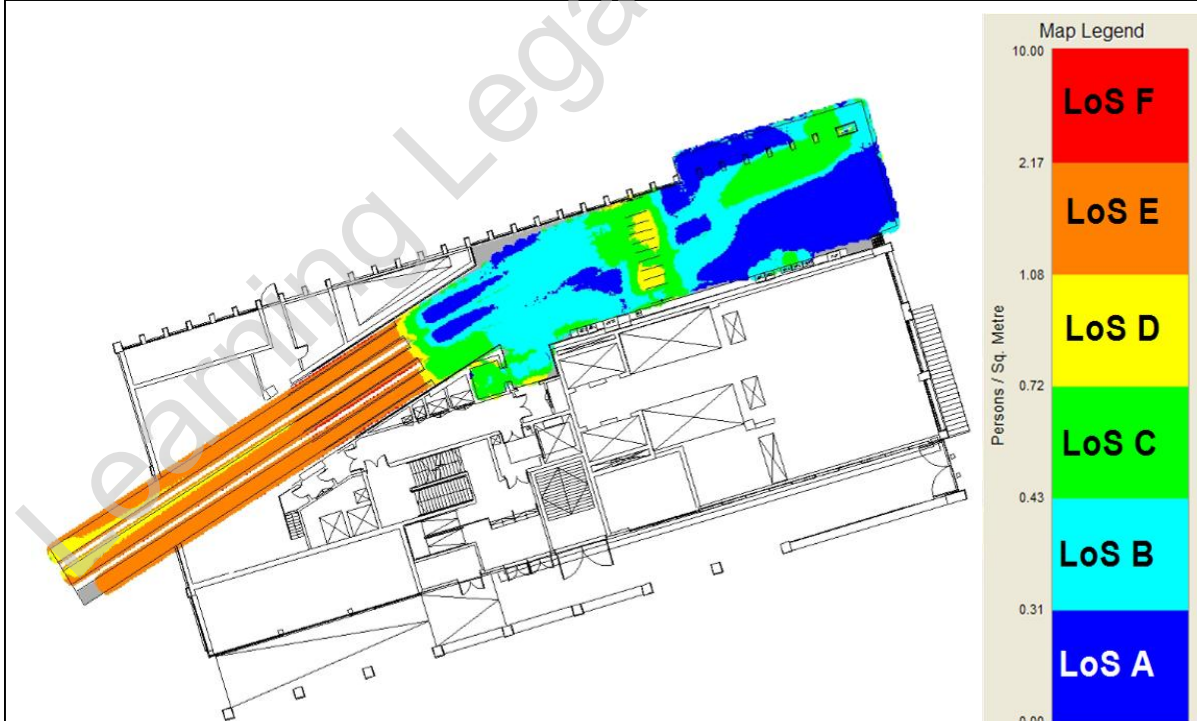
**PM Peak 2026 Stage E Design Hanover Square Ticket Hall  
 Cumulative Mean Density Queuing (18:00-18:15)**



**PM Peak 2026 Stage E Design Hanover Square Ticket Hall  
 Cumulative High Density (18:00-18:15)**

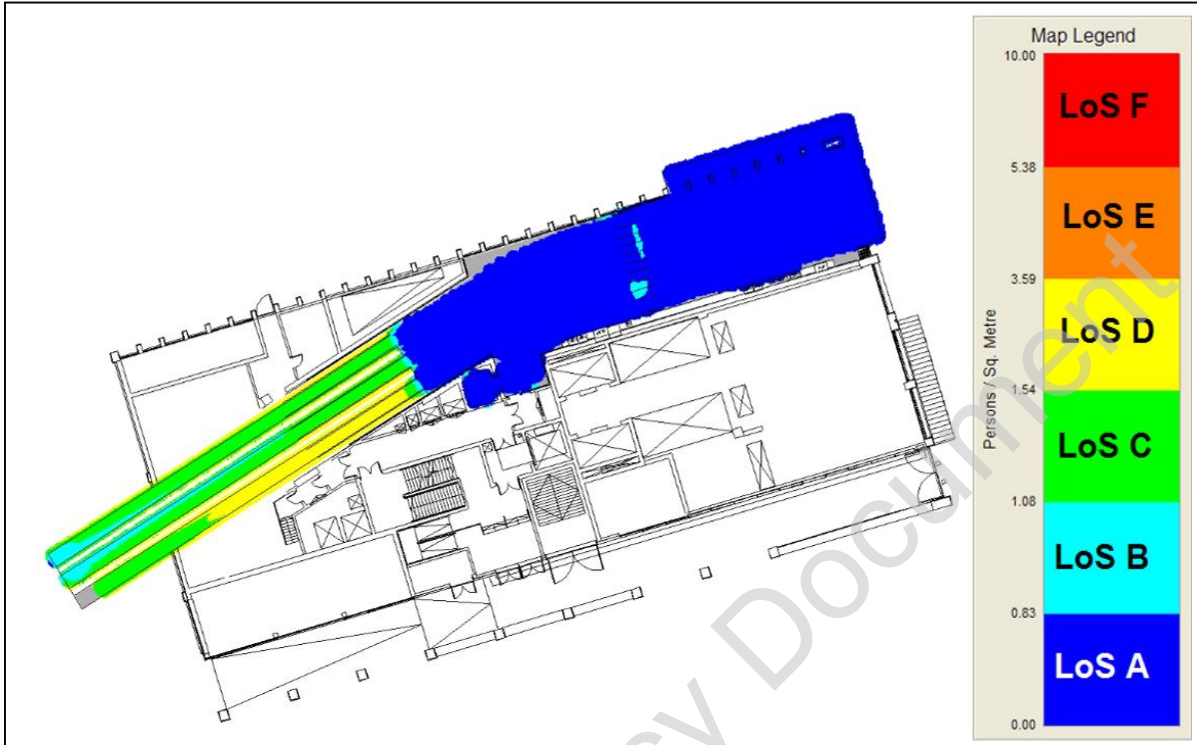


**PM Peak 2026 Stage E Design Hanover Square Ticket Hall  
 Cumulative Mean Density Walking (18:15-18:30)**

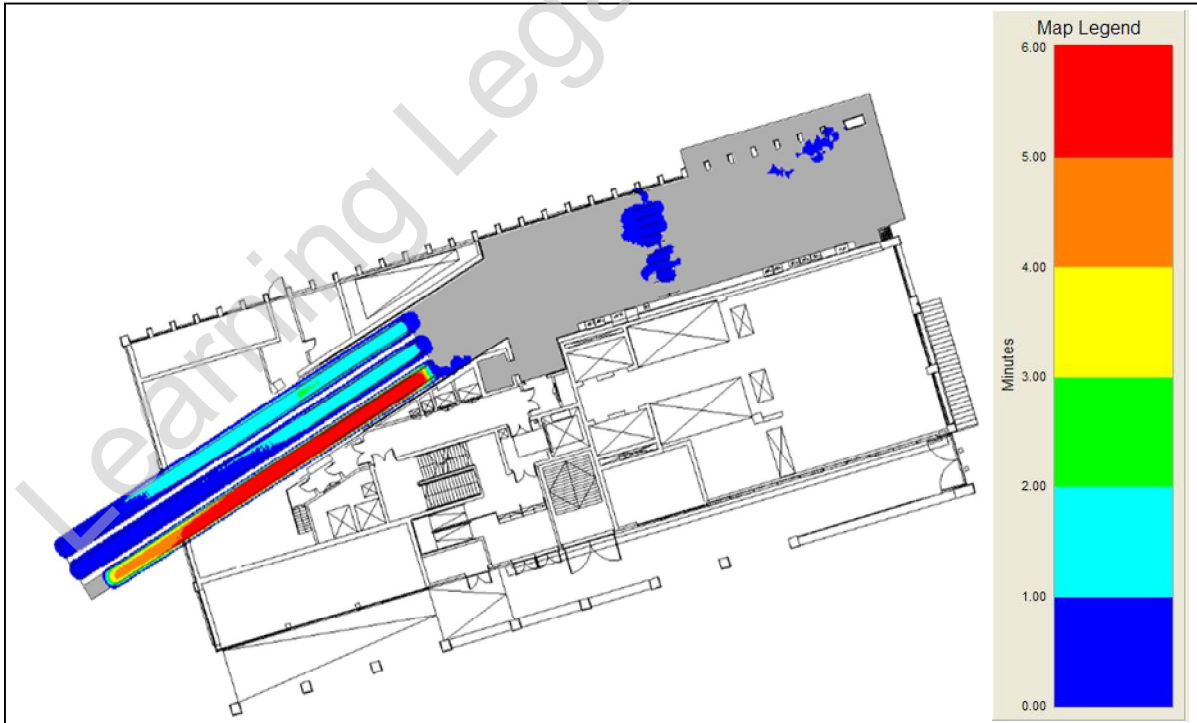




**PM Peak 2026 Stage E Design Hanover Square Ticket Hall  
 Cumulative Mean Density Queuing (18:15-18:30)**

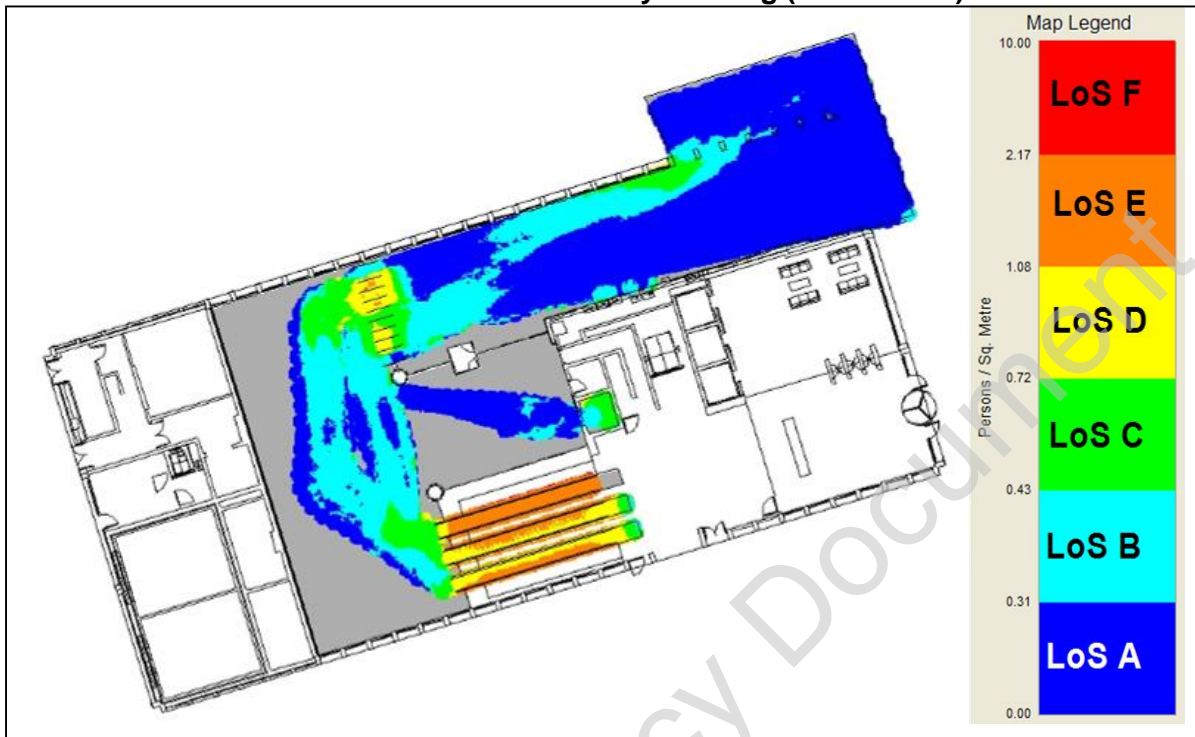


**PM Peak 2026 Stage E Design Hanover Square Ticket Hall  
 Cumulative High (18:15-18:30)**



Davies Street Ticket Hall

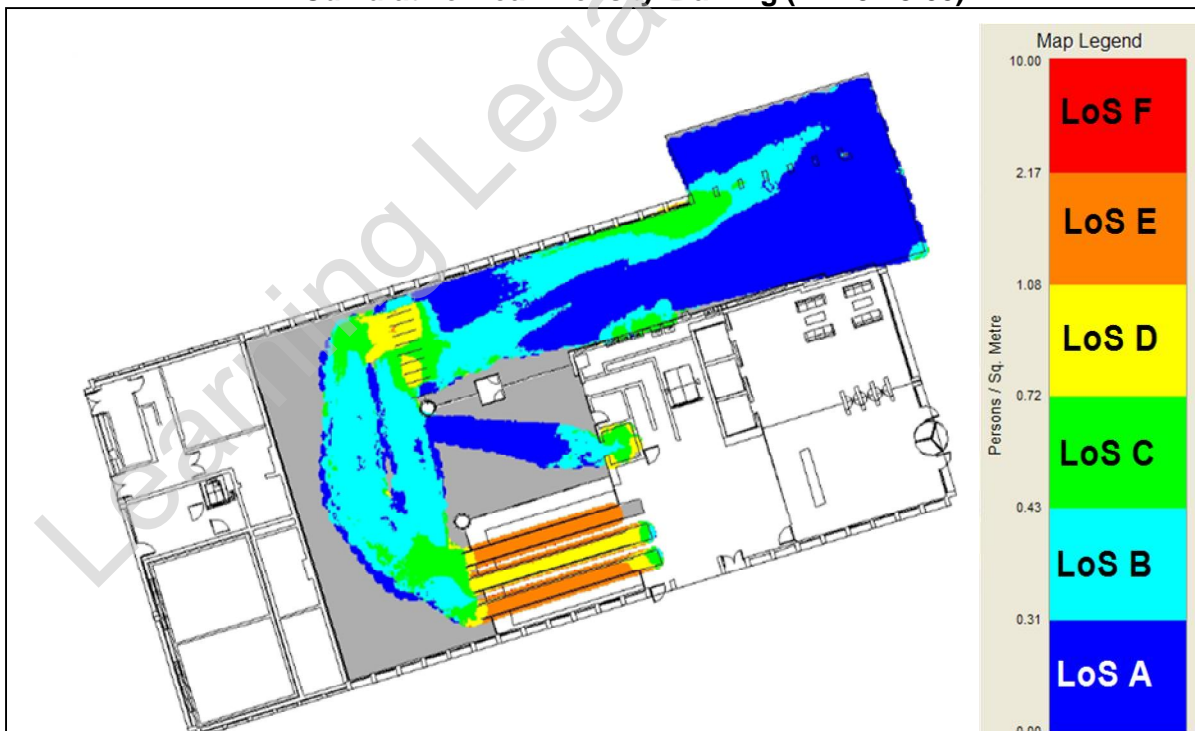
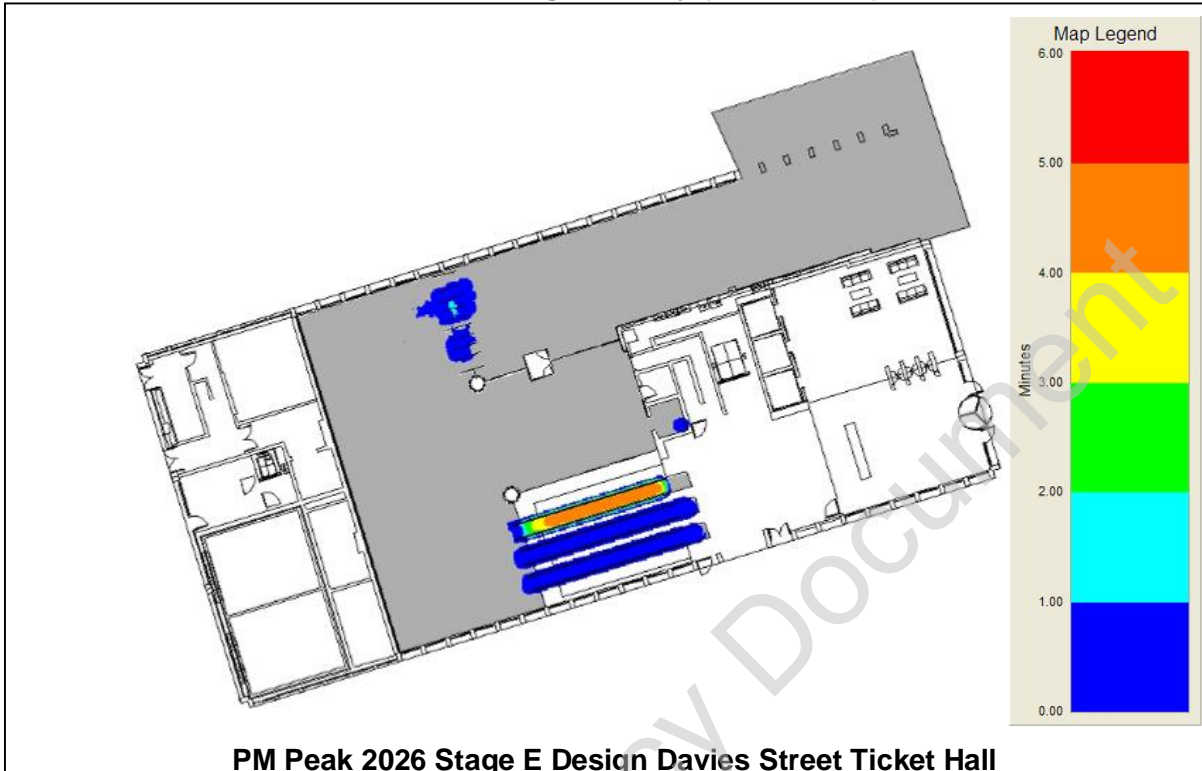
PM Peak 2026 Stage E Design Davies Street Ticket Hall  
Cumulative Mean Density Walking (17:30-17:45)



PM Peak 2026 Stage E Design Davies Street Ticket Hall  
Cumulative Mean Density Queuing (17:30-17:45)



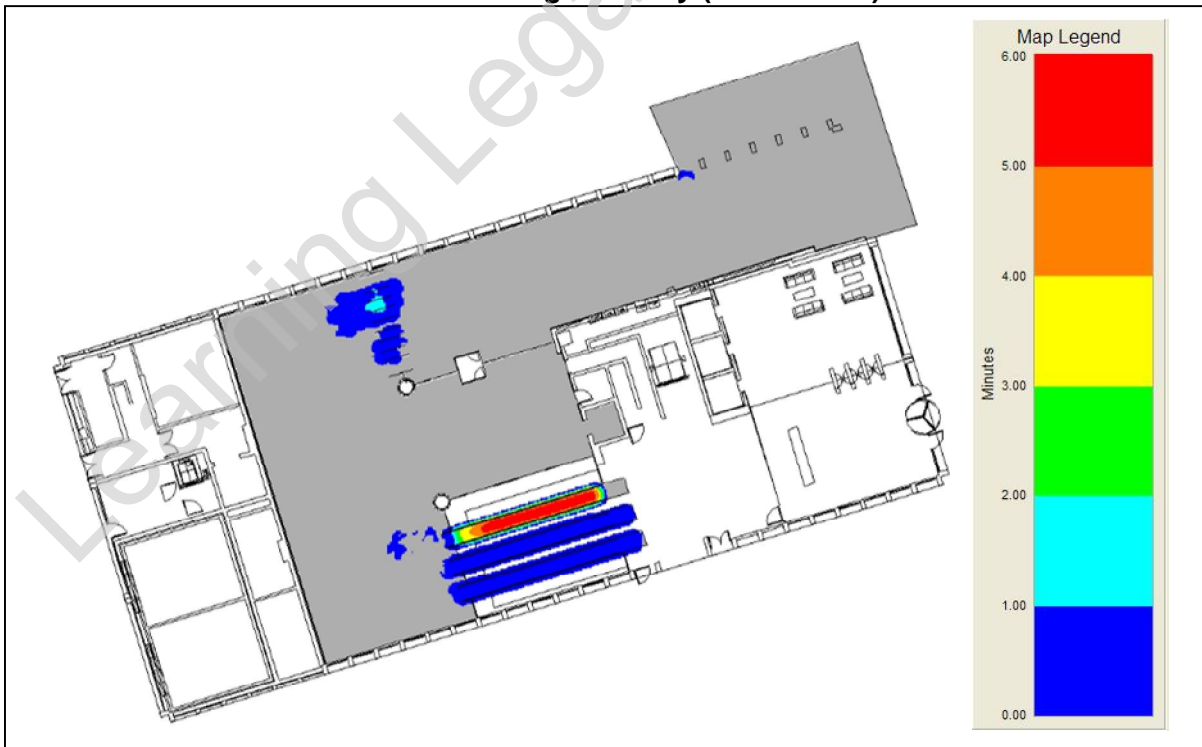
**PM Peak 2026 Stage E Design Davies Street Ticket Hall  
Cumulative High Density (17:30-17:45)**



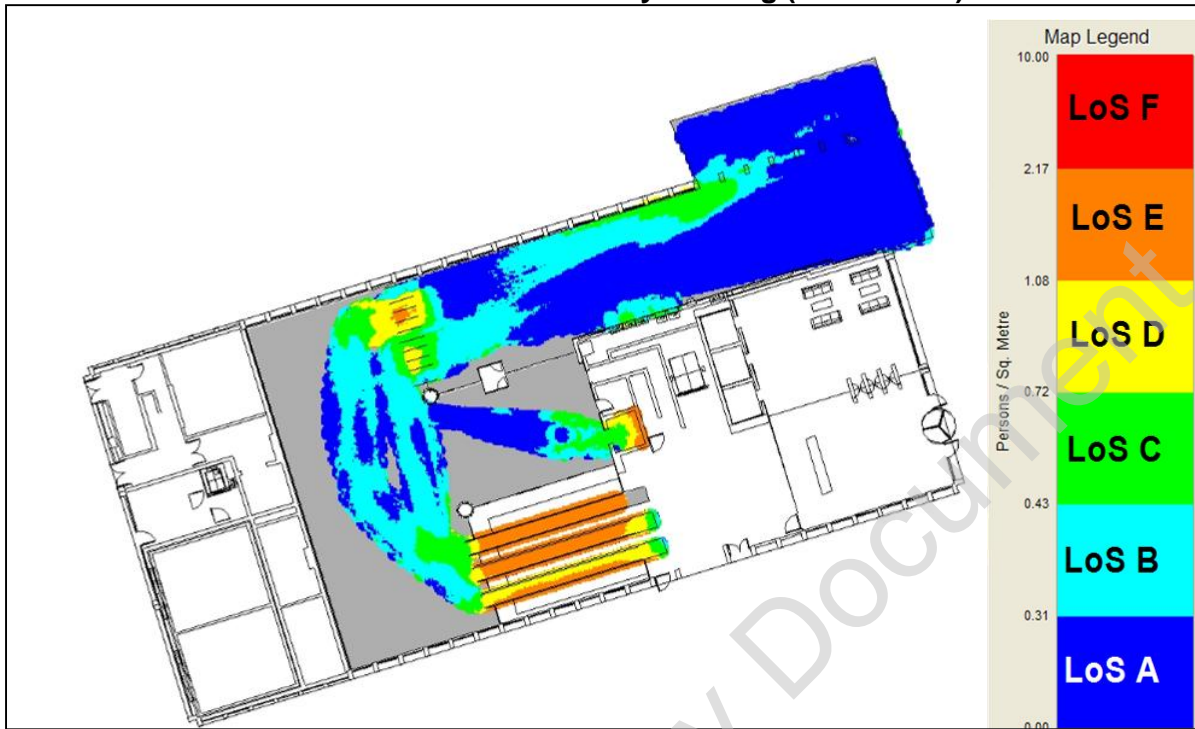
**PM Peak 2026 Stage E Design Davies Street Ticket Hall  
 Cumulative Mean Density Queuing (17:45-18:00)**



**PM Peak 2026 Stage E Design Davies Street Ticket Hall  
 Cumulative High Density (17:45-18:00)**



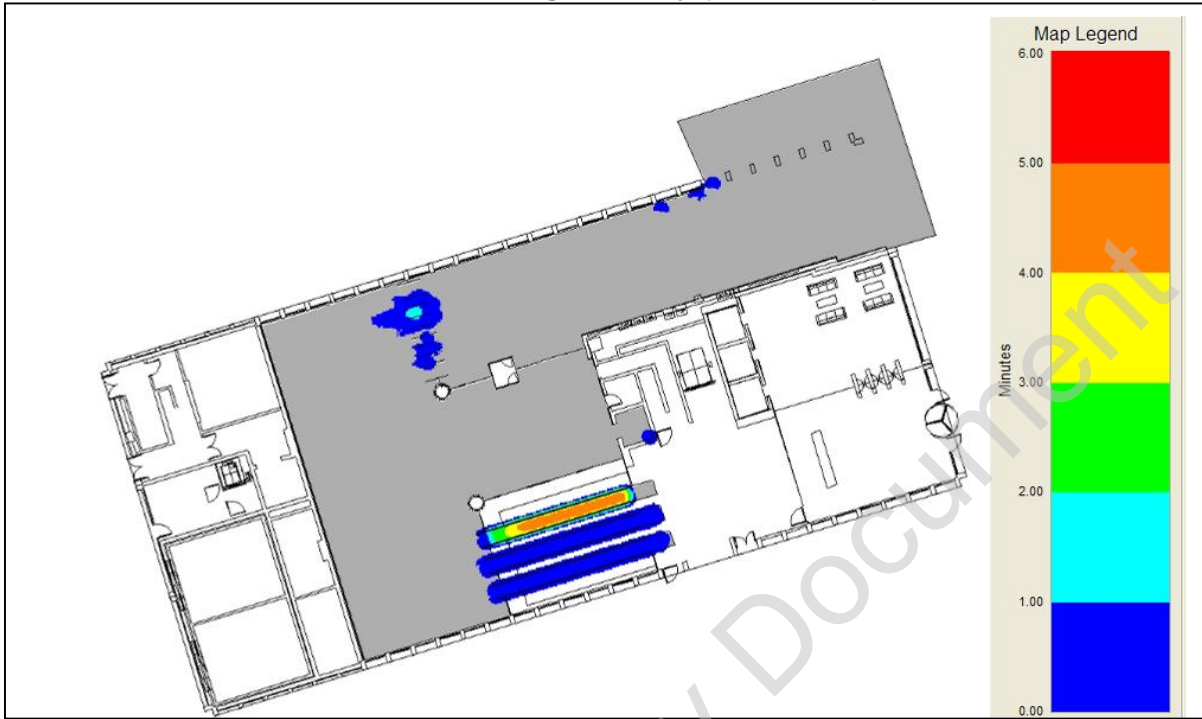
**PM Peak 2026 Stage E Design Davies Street Ticket Hall  
 Cumulative Mean Density Walking (18:00-18:15)**



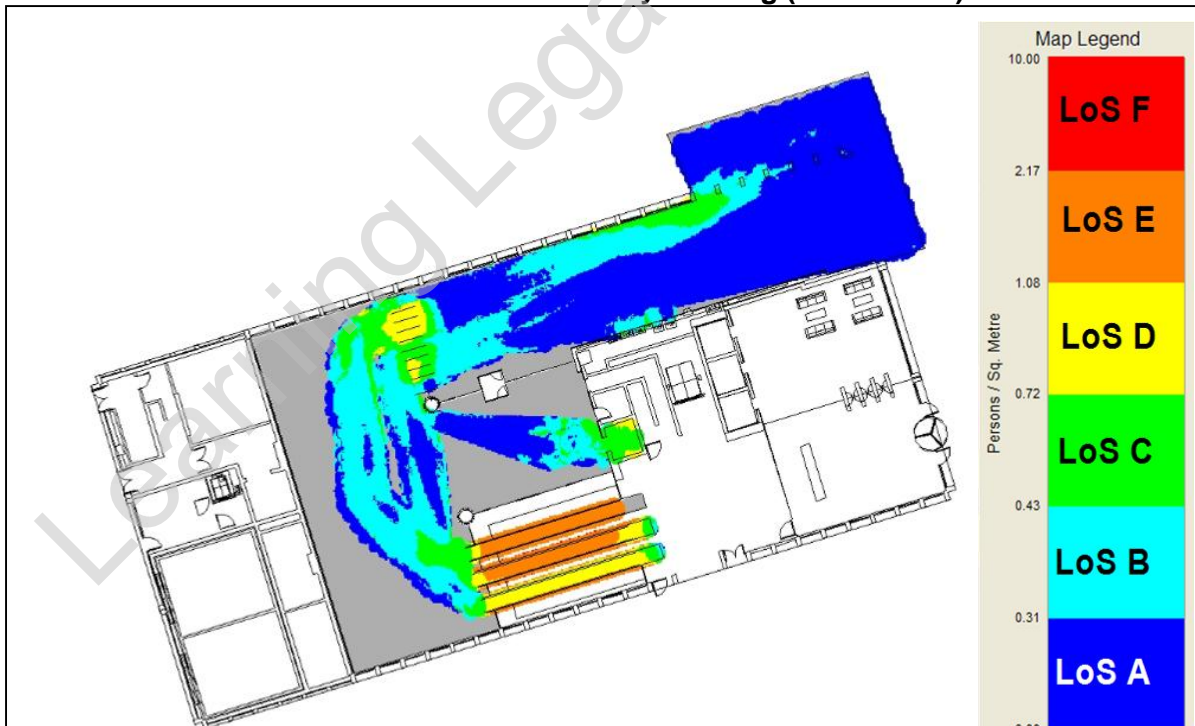
**PM Peak 2026 Stage E Design Davies Street Ticket Hall  
 Cumulative Mean Density Queuing (18:00-18:15)**



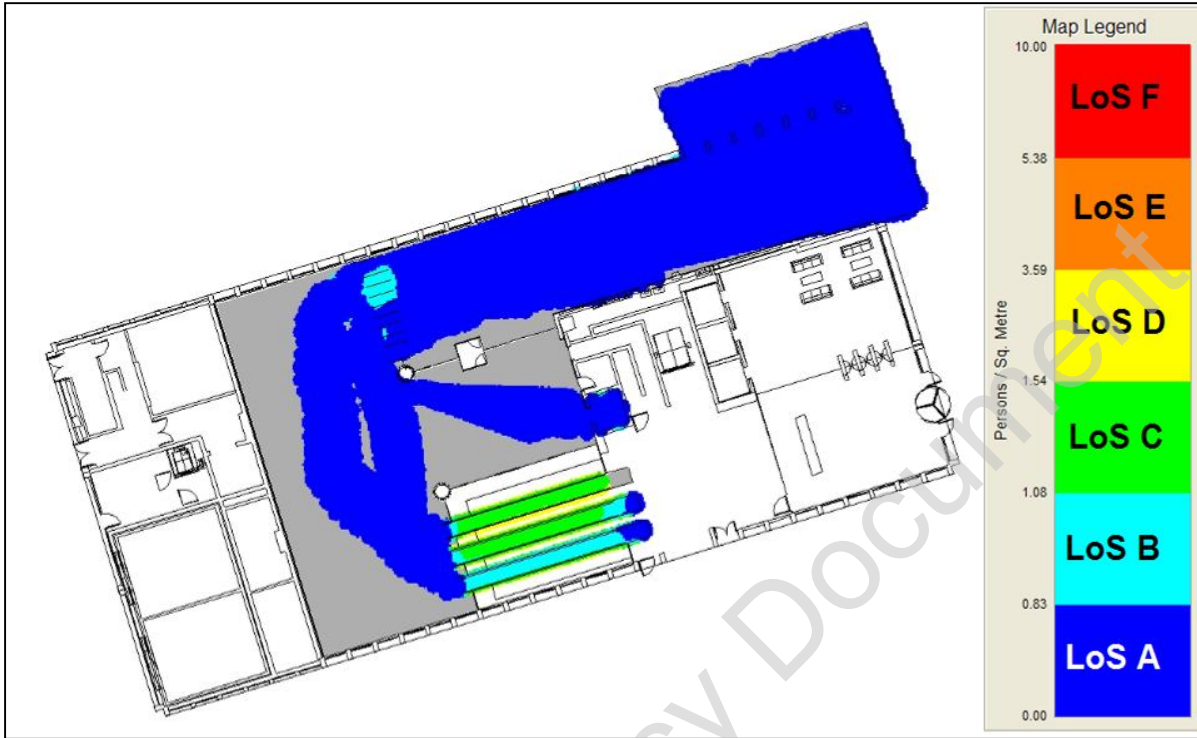
**PM Peak 2026 Stage E Design Davies Street Ticket Hall  
 Cumulative High Density (18:00-18:15)**



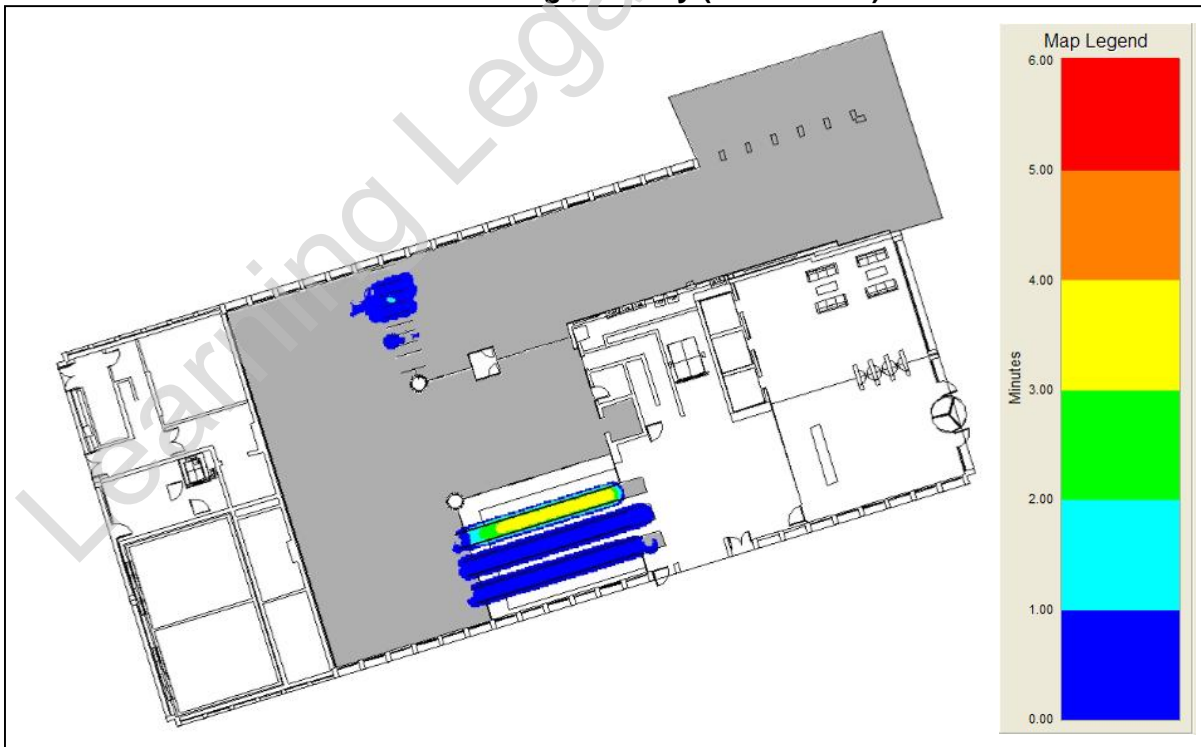
**PM Peak 2026 Stage E Design Davies Street Ticket Hall  
 Cumulative Mean Density Walking (18:15-18:30)**



**PM Peak 2026 Stage E Design Davies Street Ticket Hall  
 Cumulative Mean Density Queuing (18:15-18:30)**

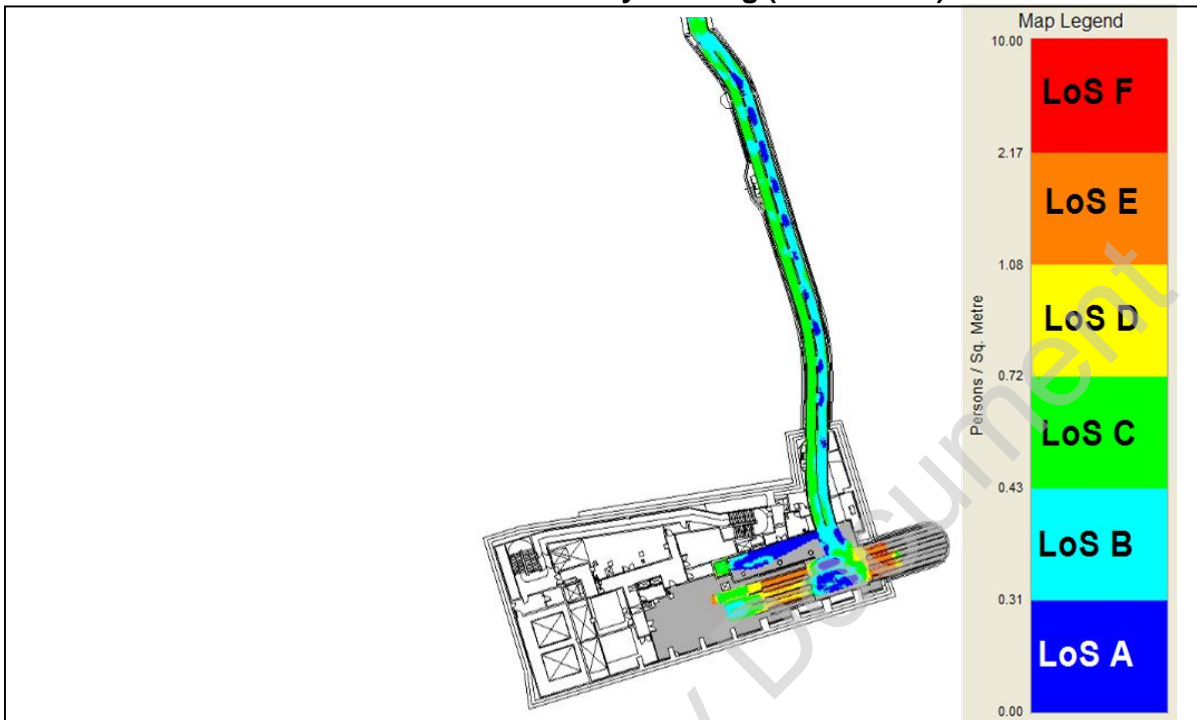


**PM Peak 2026 Stage E Design Davies Street Ticket Hall  
 Cumulative High Density (18:15-18:30)**

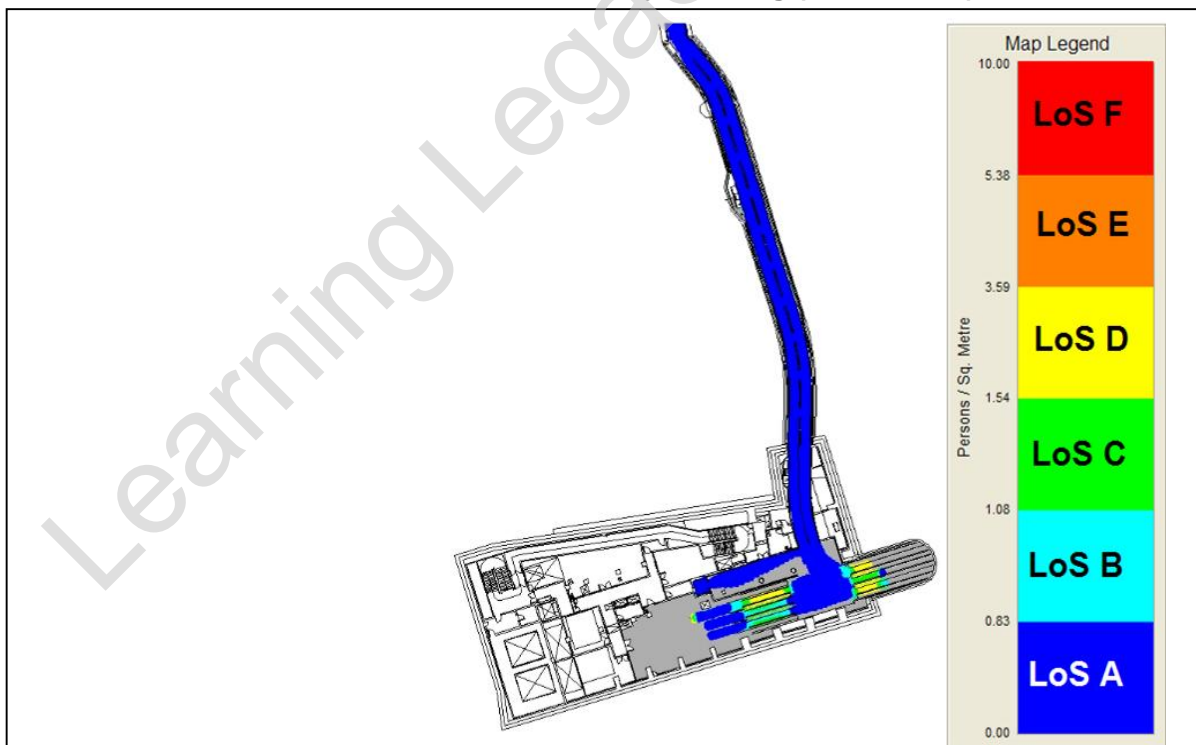


Intermediate Level

**PM Peak 2026 Stage E Design Intermediate Level  
 Cumulative Mean Density Walking (17:30-17:45)**

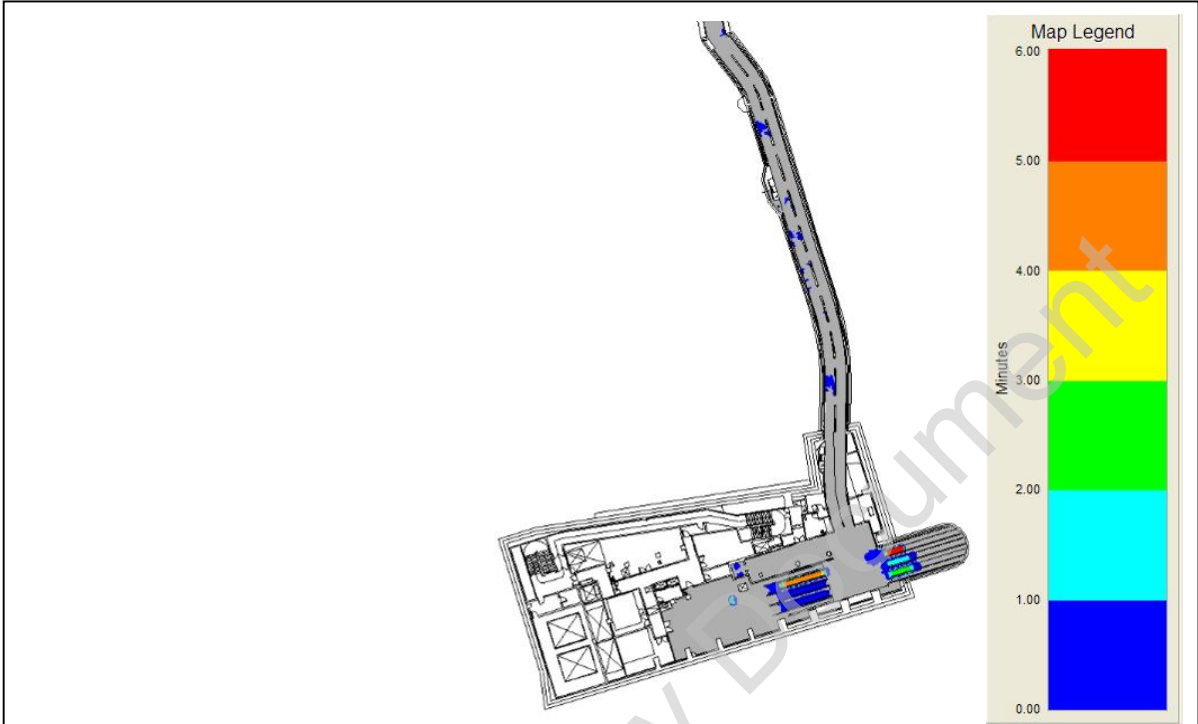


**PM Peak 2026 Stage E Design Intermediate Level  
 Cumulative Mean Density Queuing (17:30-17:45)**

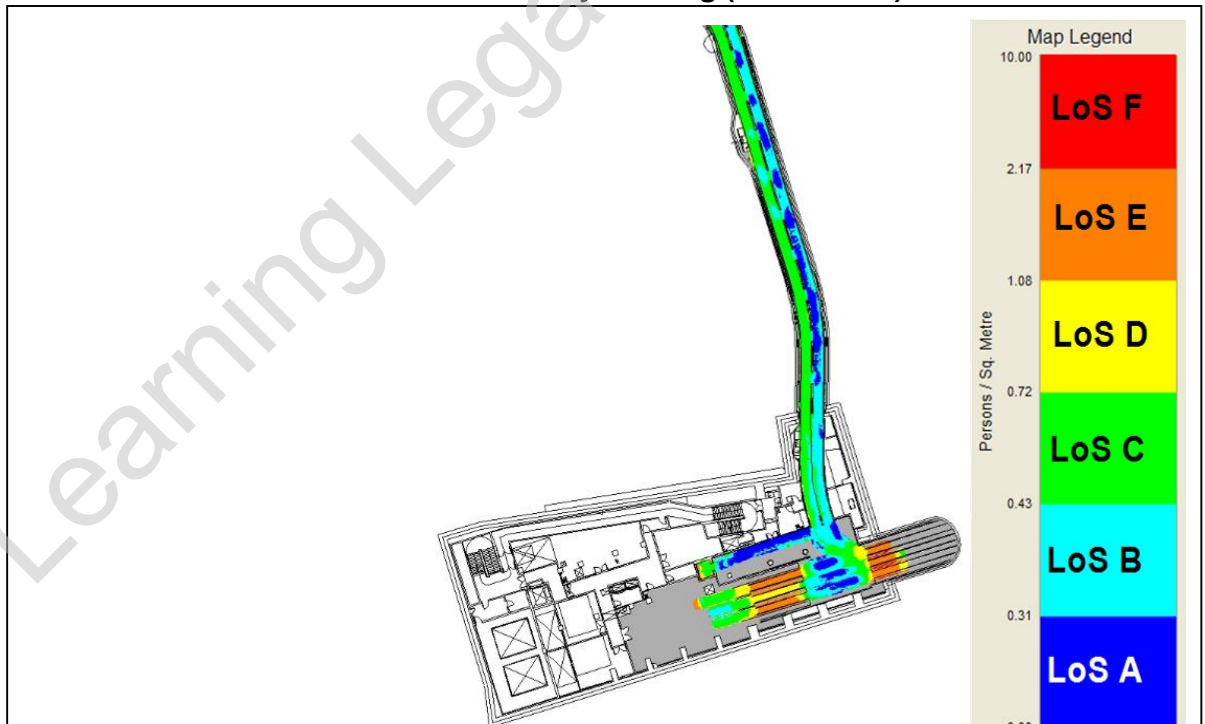




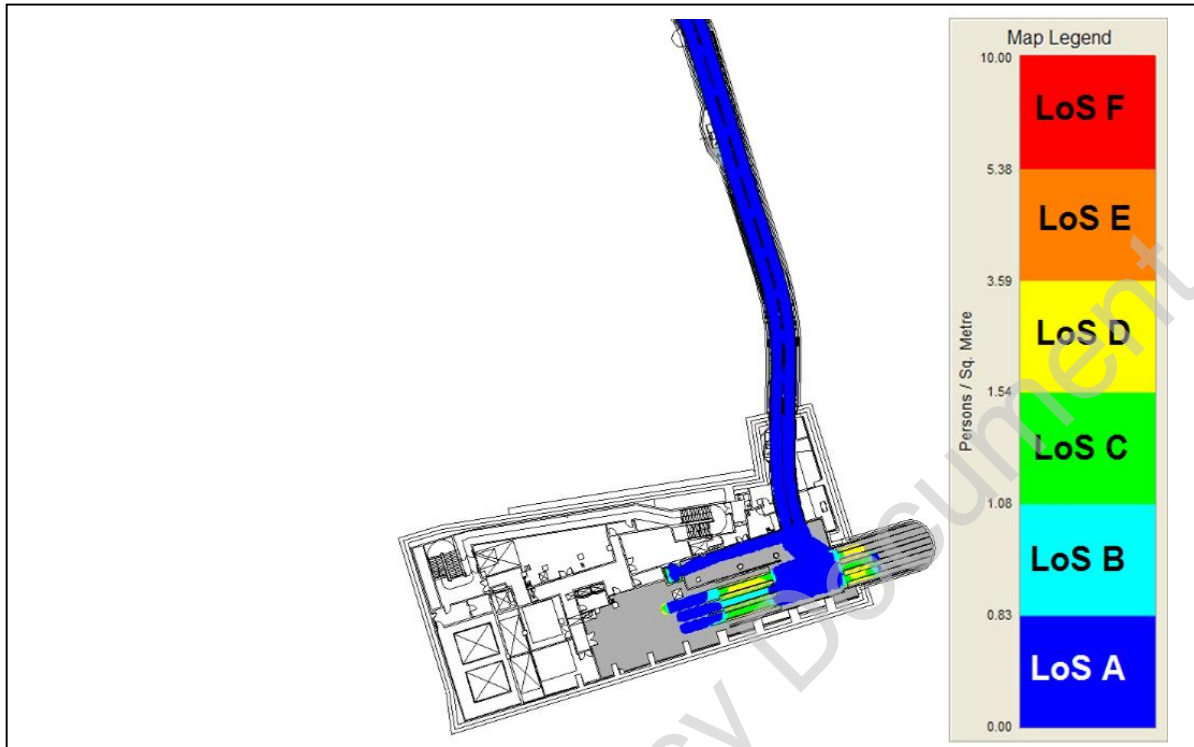
**PM Peak 2026 Stage E Design Intermediate Level  
 Cumulative High Density (17:30-17:45)**



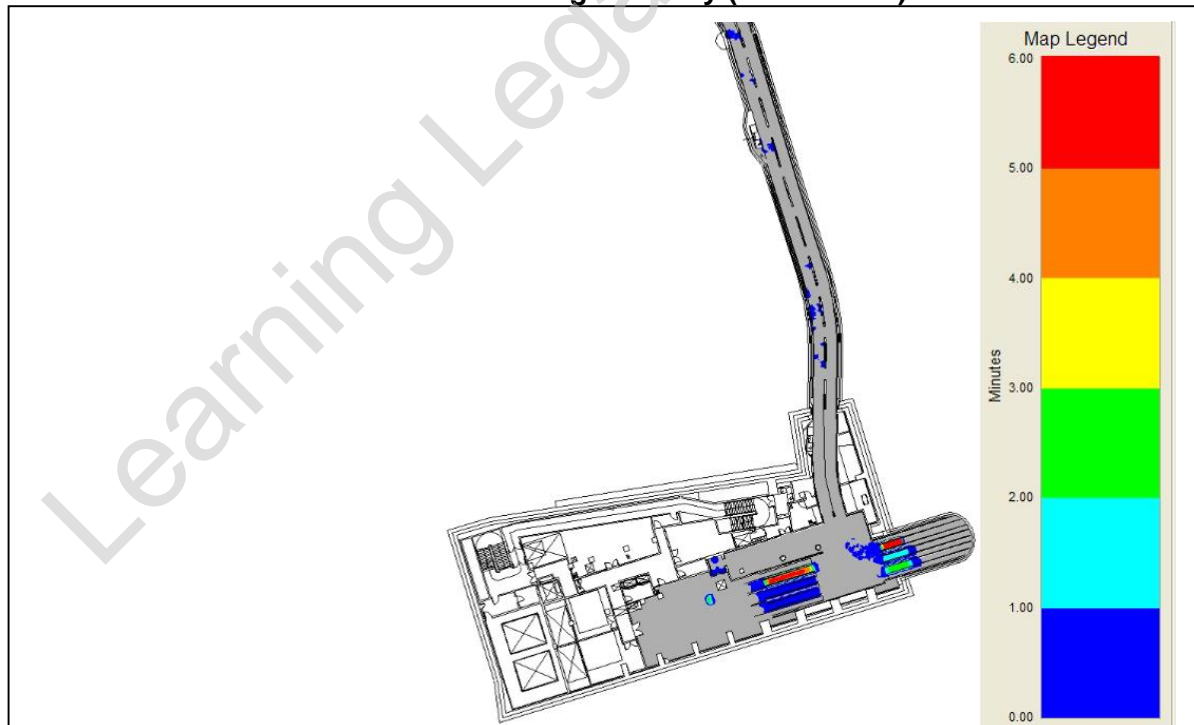
**PM Peak 2026 Stage E Design Intermediate Level  
 Cumulative Mean Density Walking (17:45-18:00)**



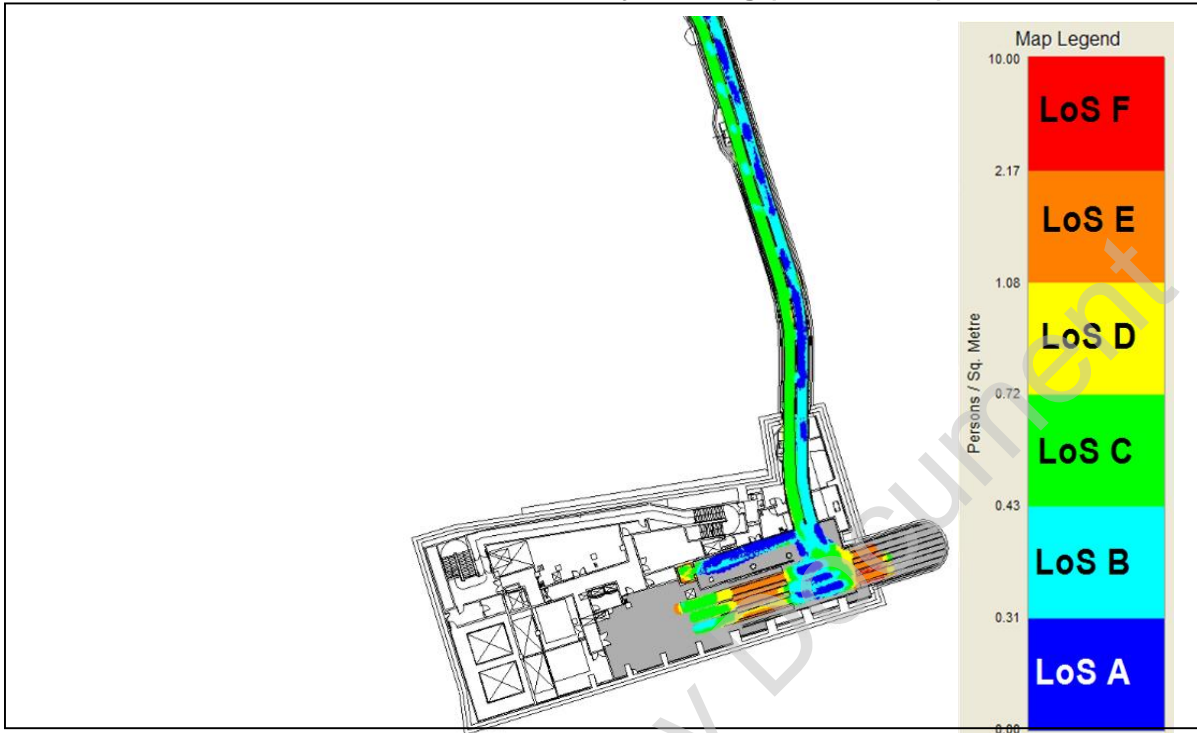
**PM Peak 2026 Stage E Design Intermediate Level  
 Cumulative Mean Density Queuing (17:45-18:00)**



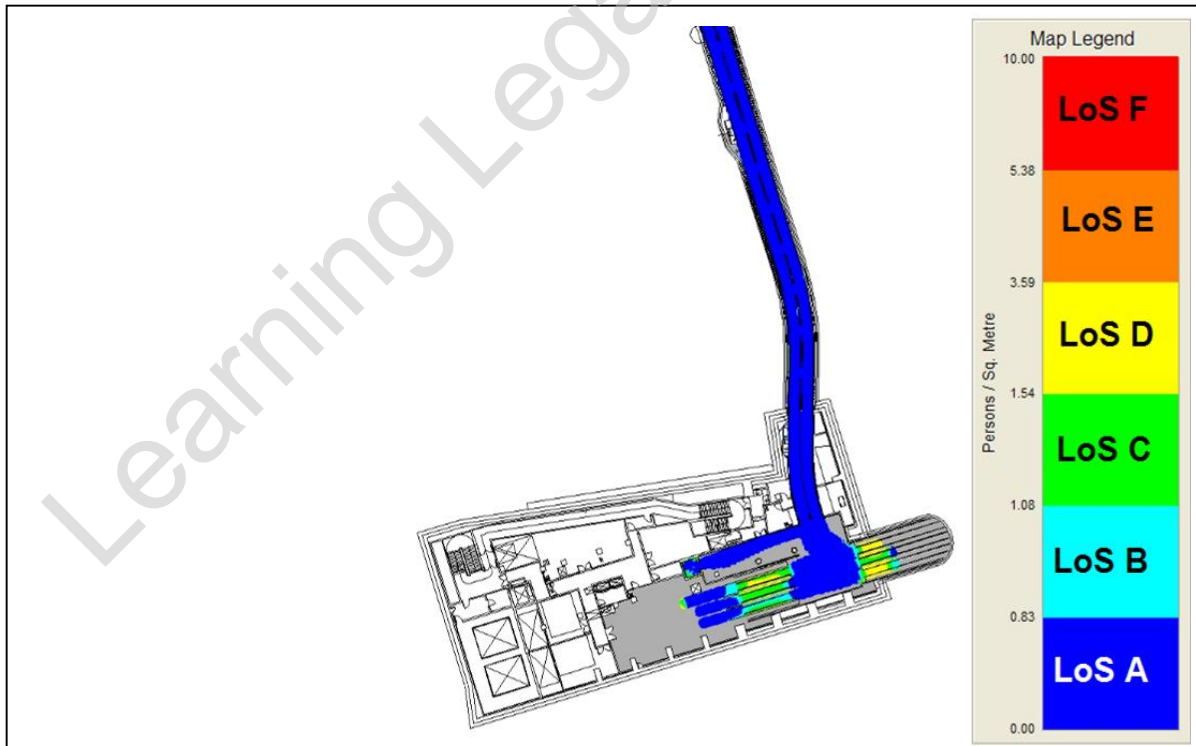
**PM Peak 2026 Stage E Design Intermediate Level  
 Cumulative High Density (17:45-18:00)**



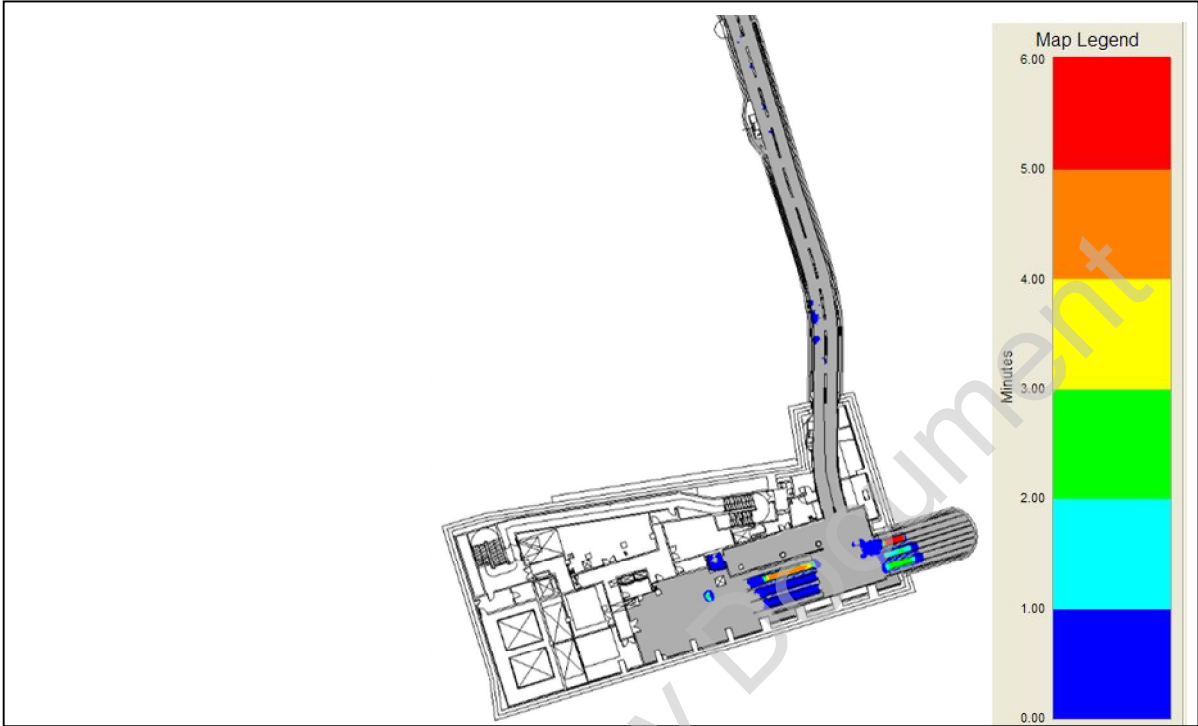
**PM Peak 2026 Stage E Design Intermediate Level  
 Cumulative Mean Density Walking (18:00-18:15)**



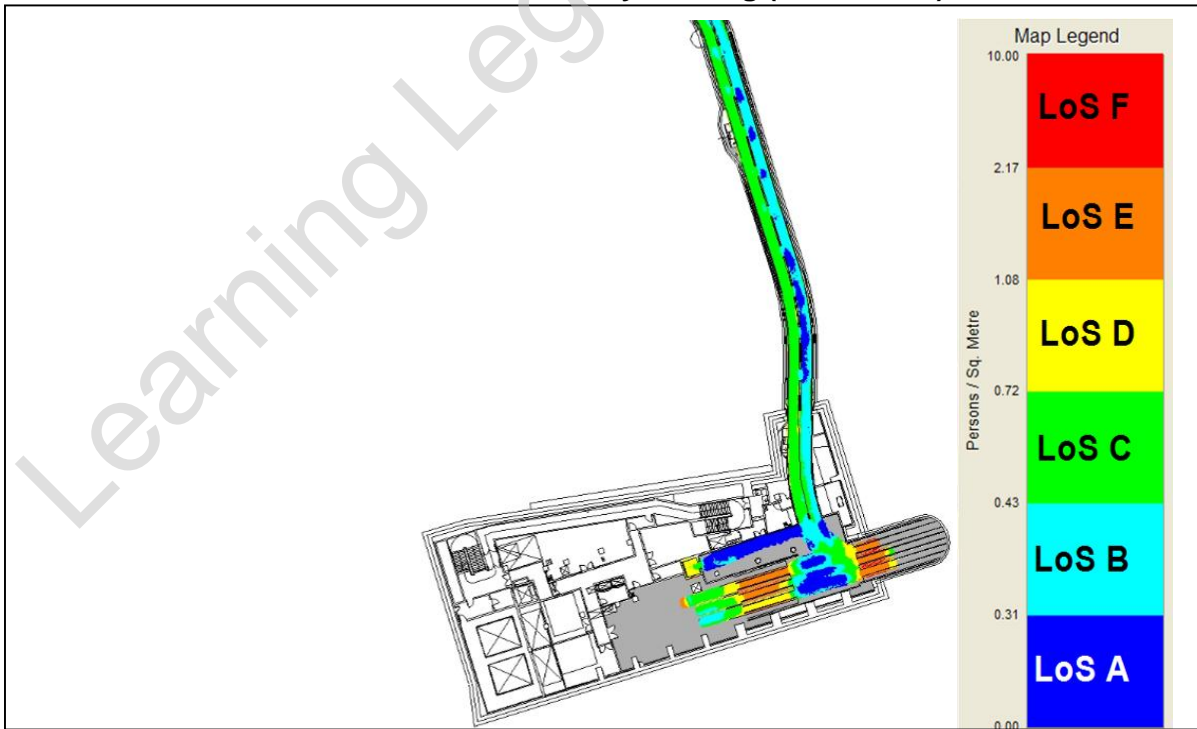
**PM Peak 2026 Stage E Design Intermediate Level  
 Cumulative Mean Density Queuing (18:00-18:15)**



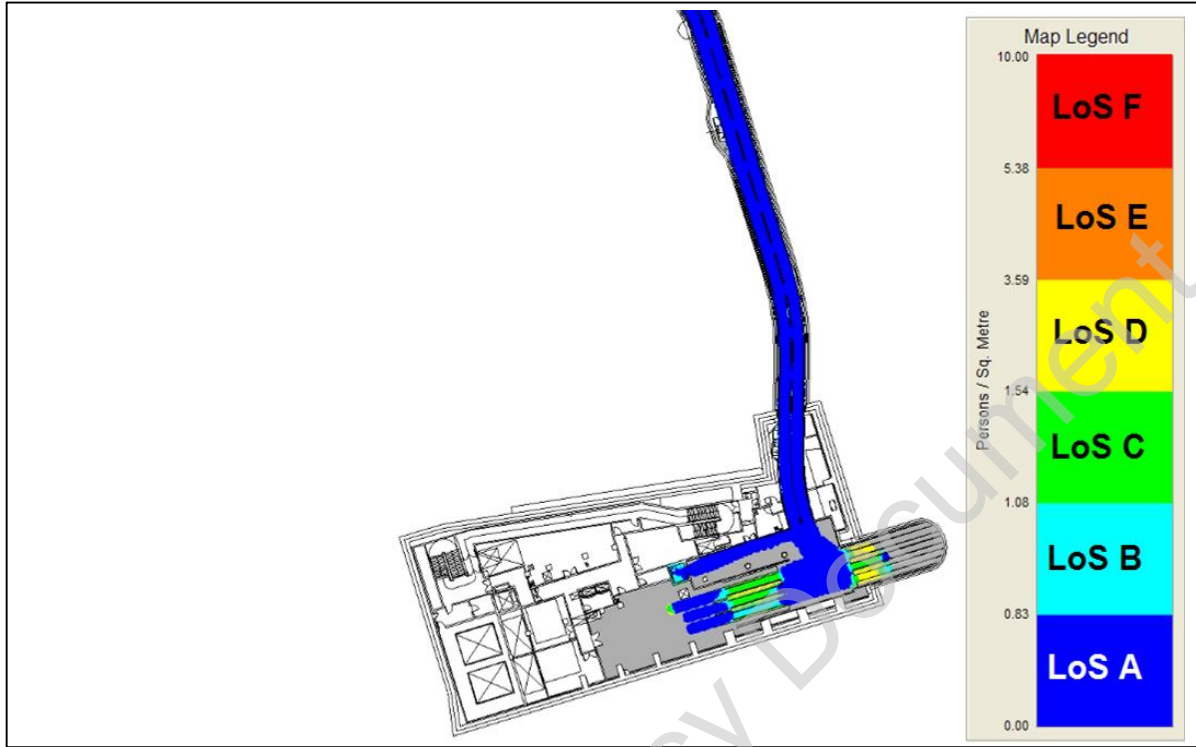
**PM Peak 2026 Stage E Design Intermediate Level  
 Cumulative High Density (18:00-18:15)**



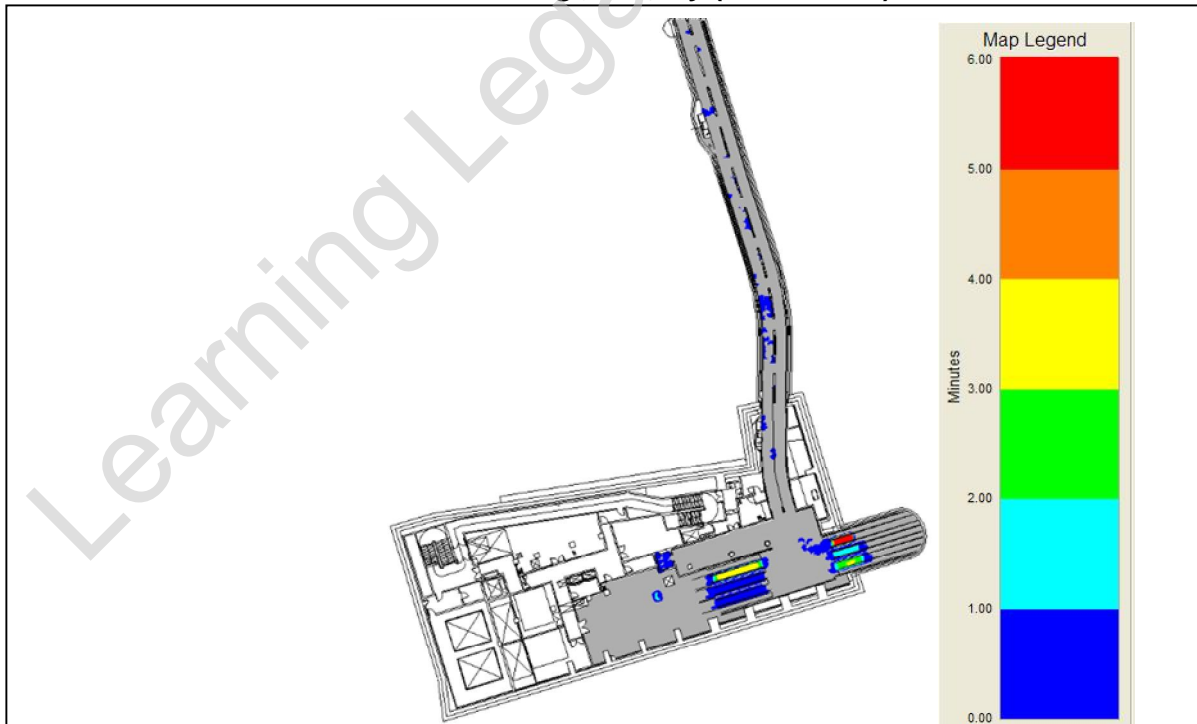
**PM Peak 2026 Stage E Design Intermediate Level  
 Cumulative Mean Density Walking (18:15-18:30)**



**PM Peak 2026 Stage E Design Intermediate Level  
 Cumulative Mean Density Queuing (18:15-18:30)**



**PM Peak 2026 Stage E Design Intermediate Level  
 Cumulative High Density (18:15-18:30)**

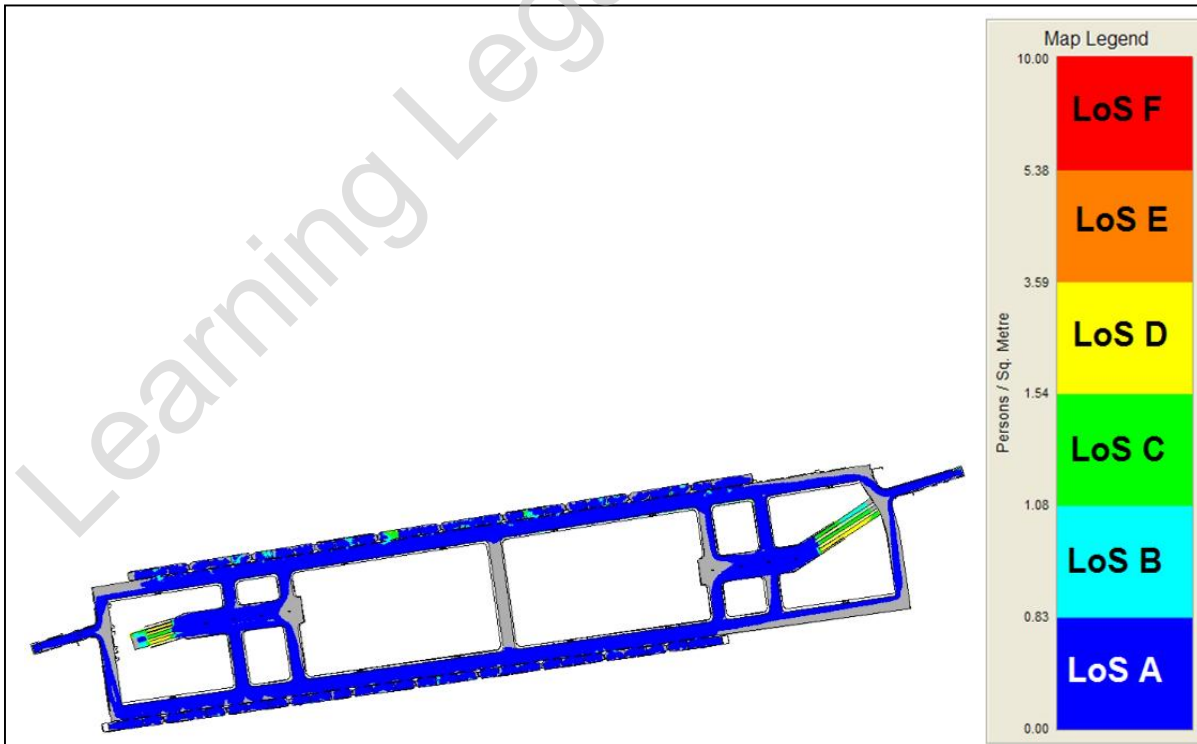


Platform Level

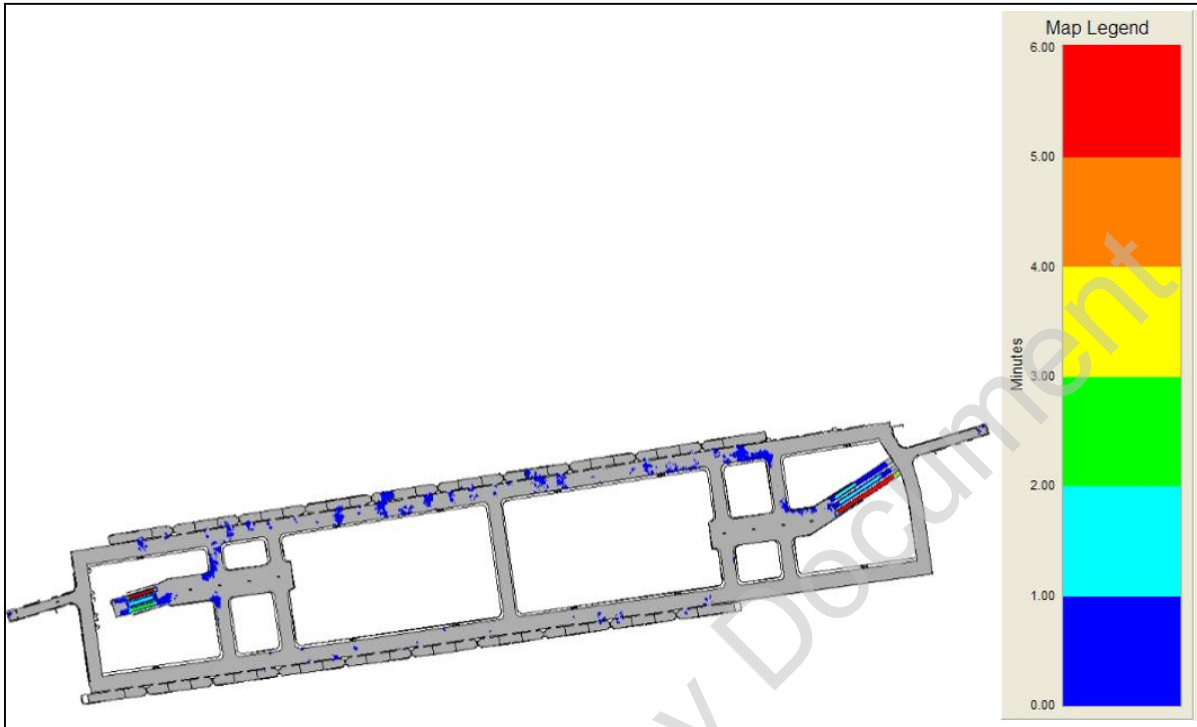
PM Peak 2026 Stage E Design Platform Level  
 Cumulative Mean Density Walking (17:30-17:45)



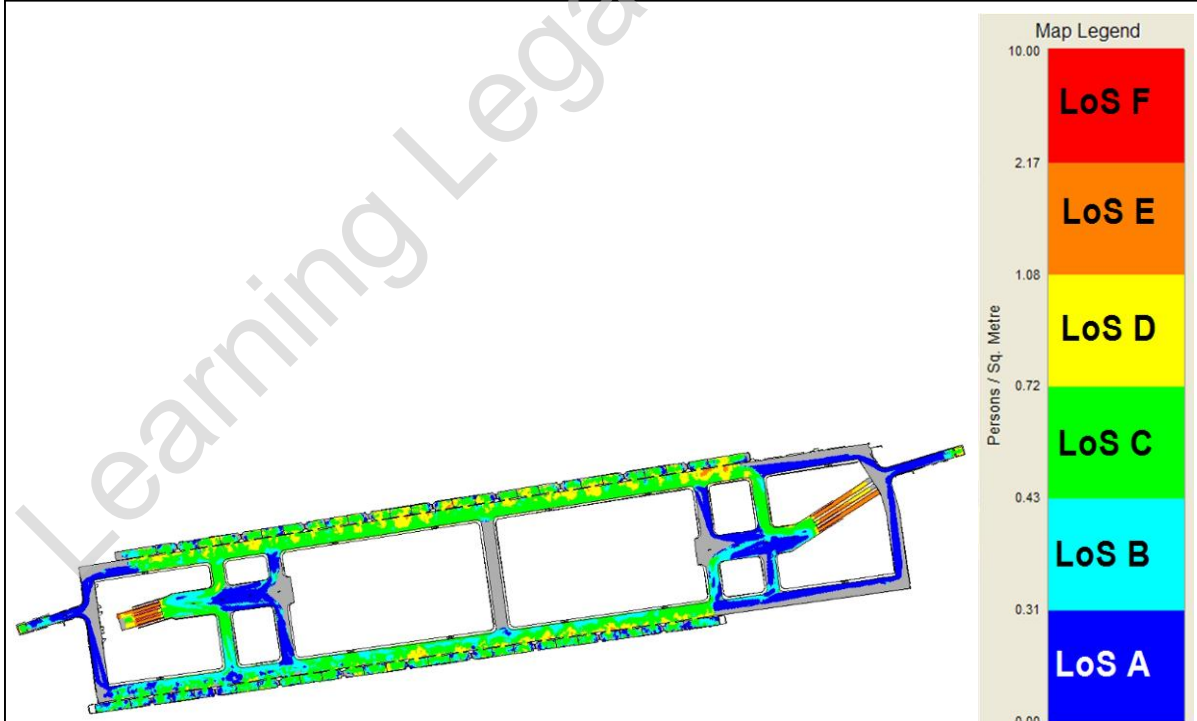
PM Peak 2026 Stage E Design Platform Level  
 Cumulative Mean Density Queuing (17:30-17:45)



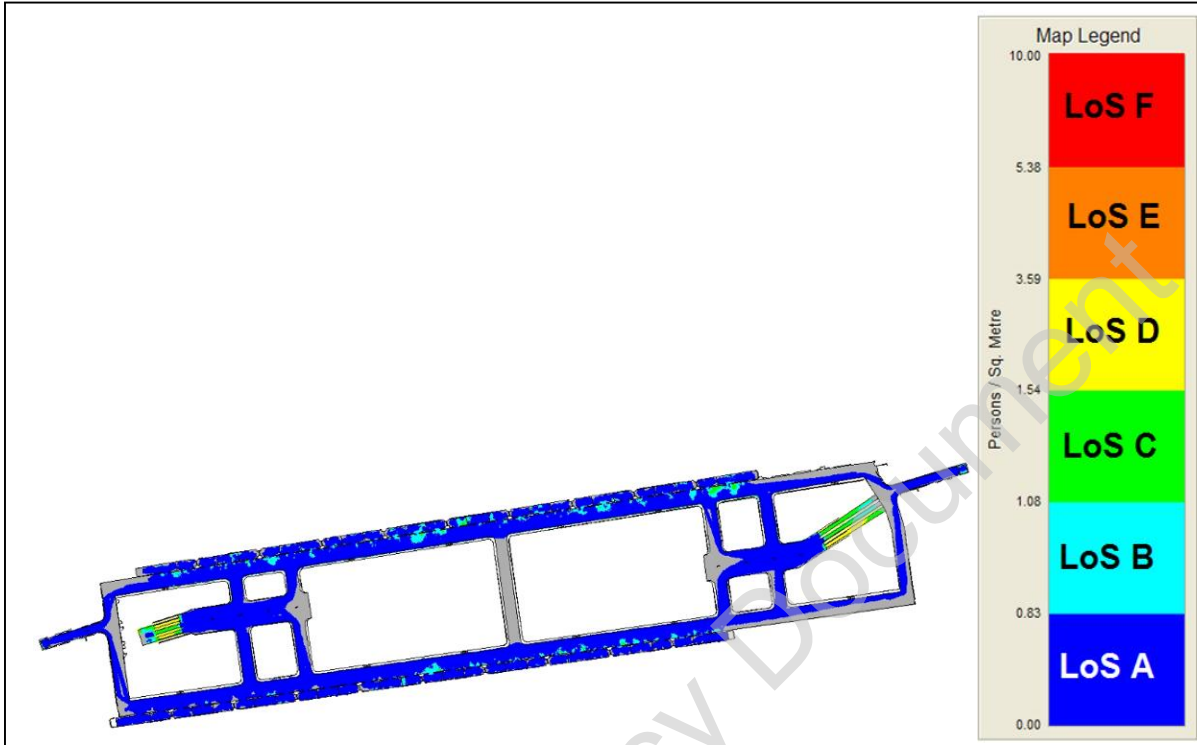
**PM Peak 2026 Stage E Design Platform Level  
 Cumulative High Density (17:30-17:45)**



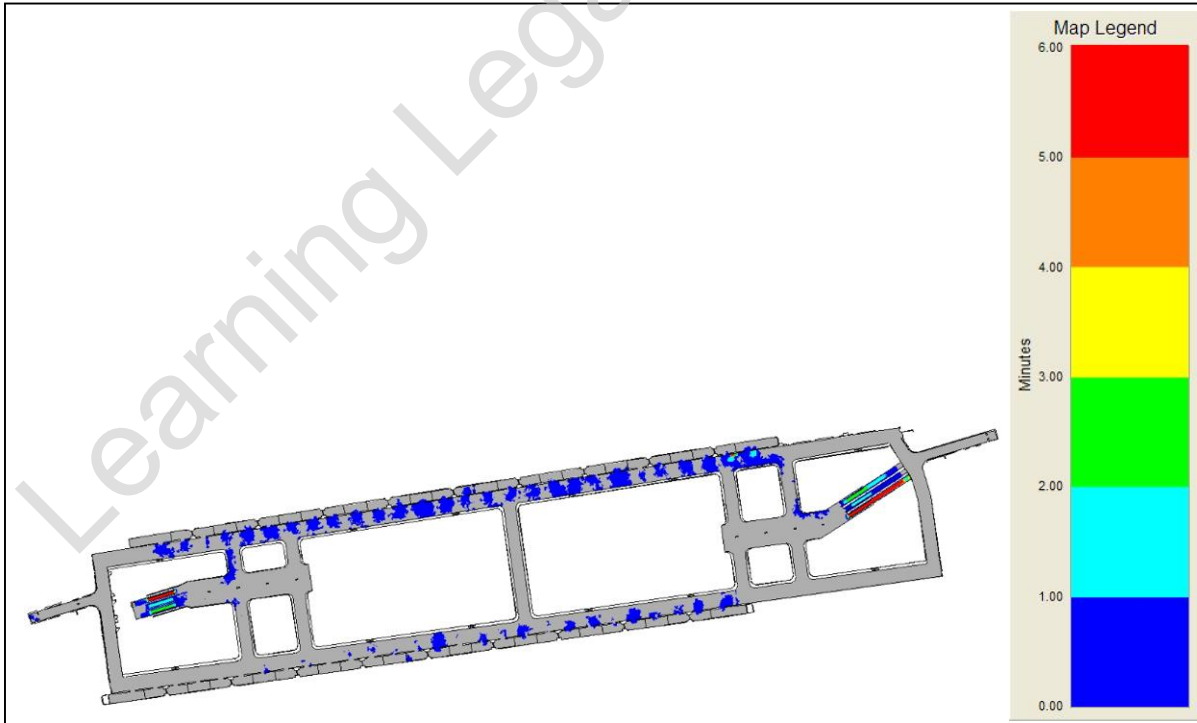
**PM Peak 2026 Stage E Design Platform Level  
 Cumulative Mean Density Walking (17:45-18:00)**



**PM Peak 2026 Stage E Design Platform Level  
 Cumulative Mean Density Queuing (17:45-18:00)**

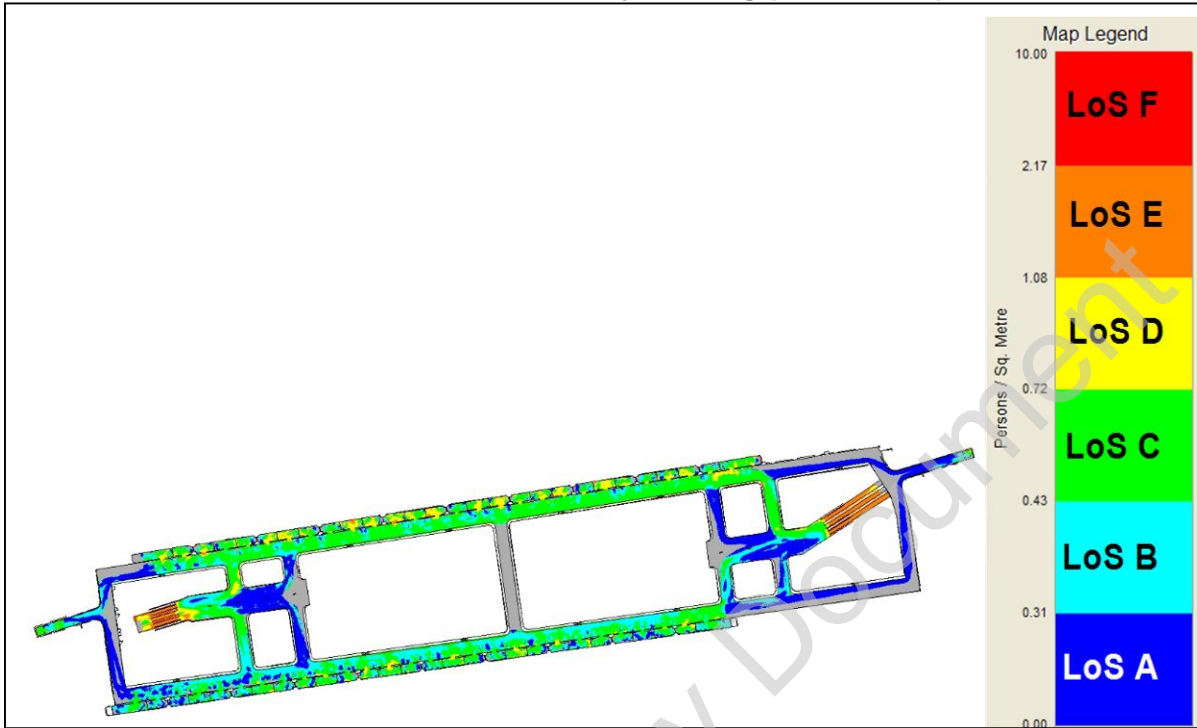


**PM Peak 2026 Stage E Design Platform Level  
 Cumulative High Density (17:45-18:00)**

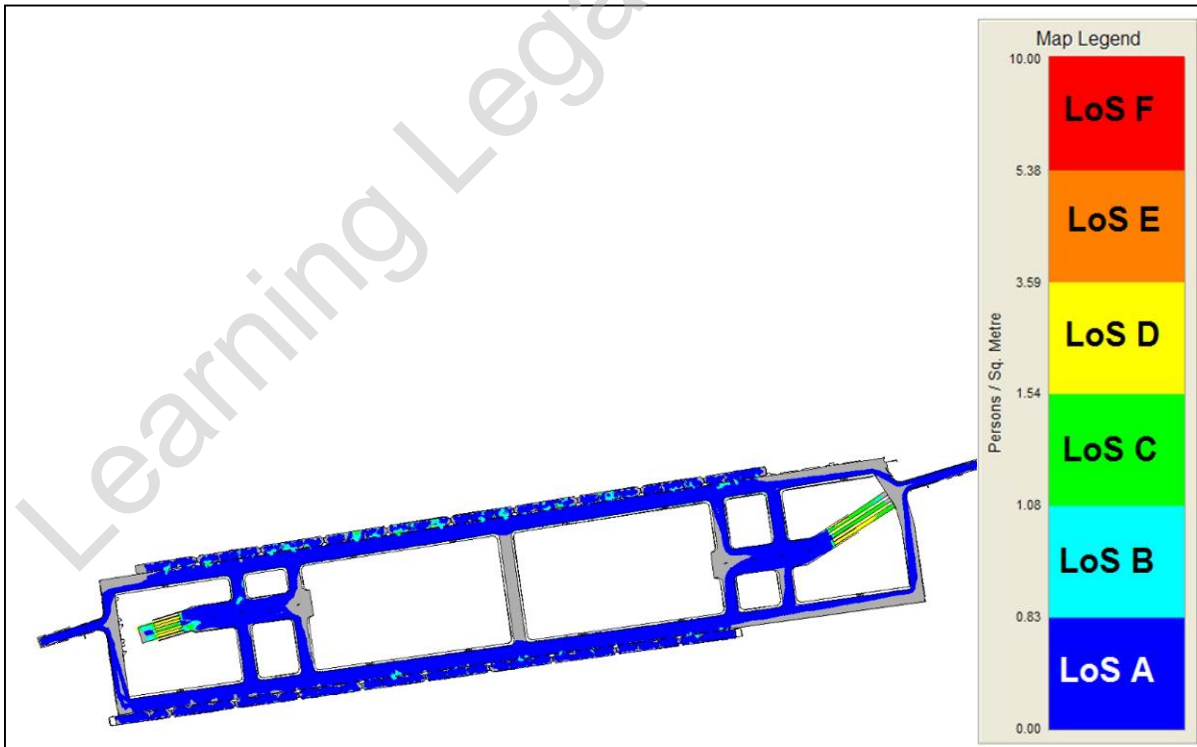




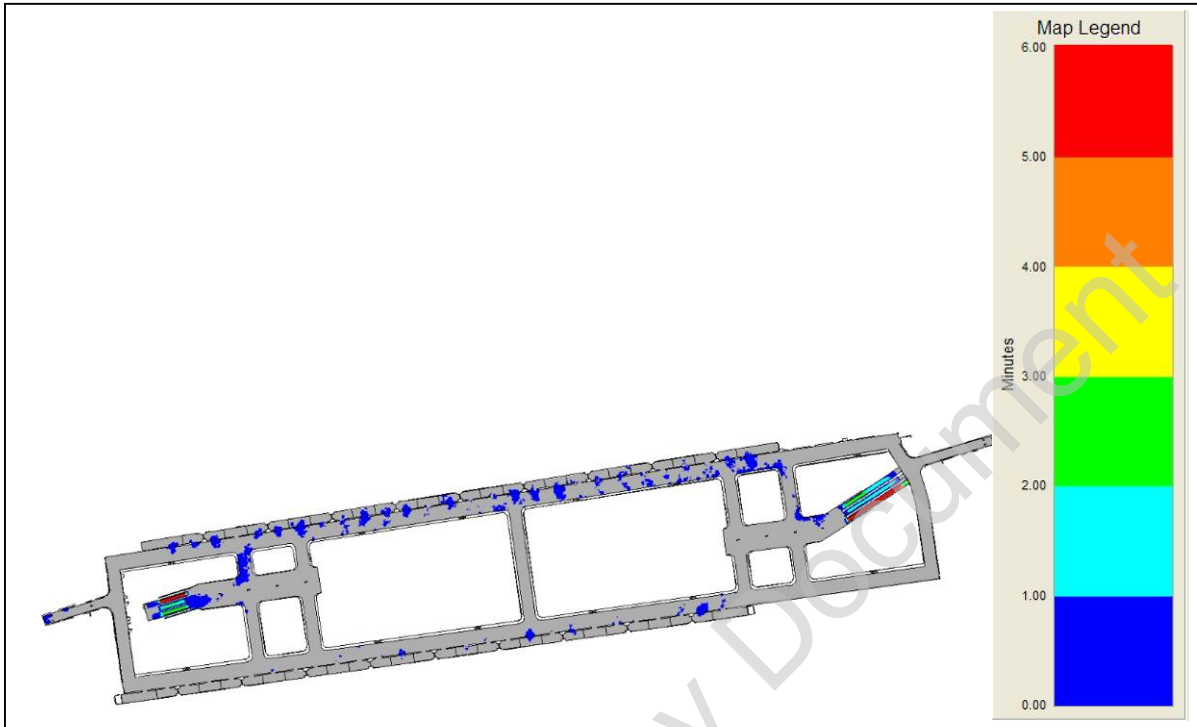
**PM Peak 2026 Stage E Design Platform Level  
 Cumulative Mean Density Walking (18:00-18:15)**



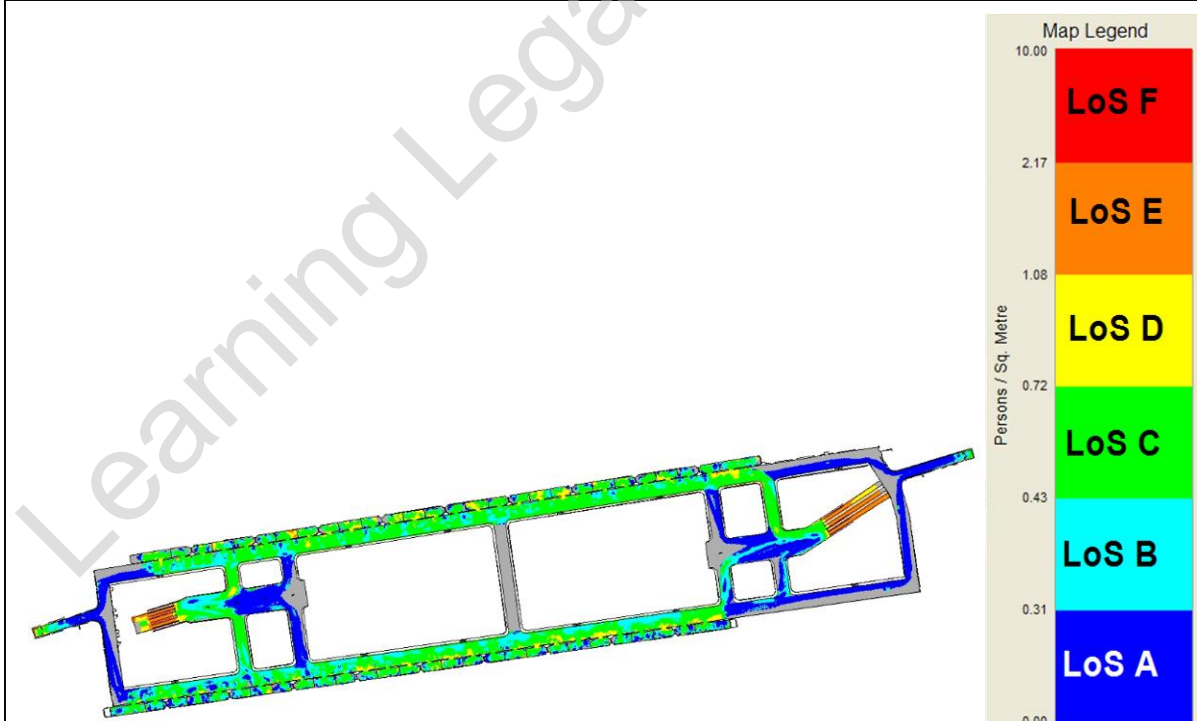
**PM Peak 2026 Stage E Design Platform Level  
 Cumulative Mean Density Queuing (18:00-18:15)**



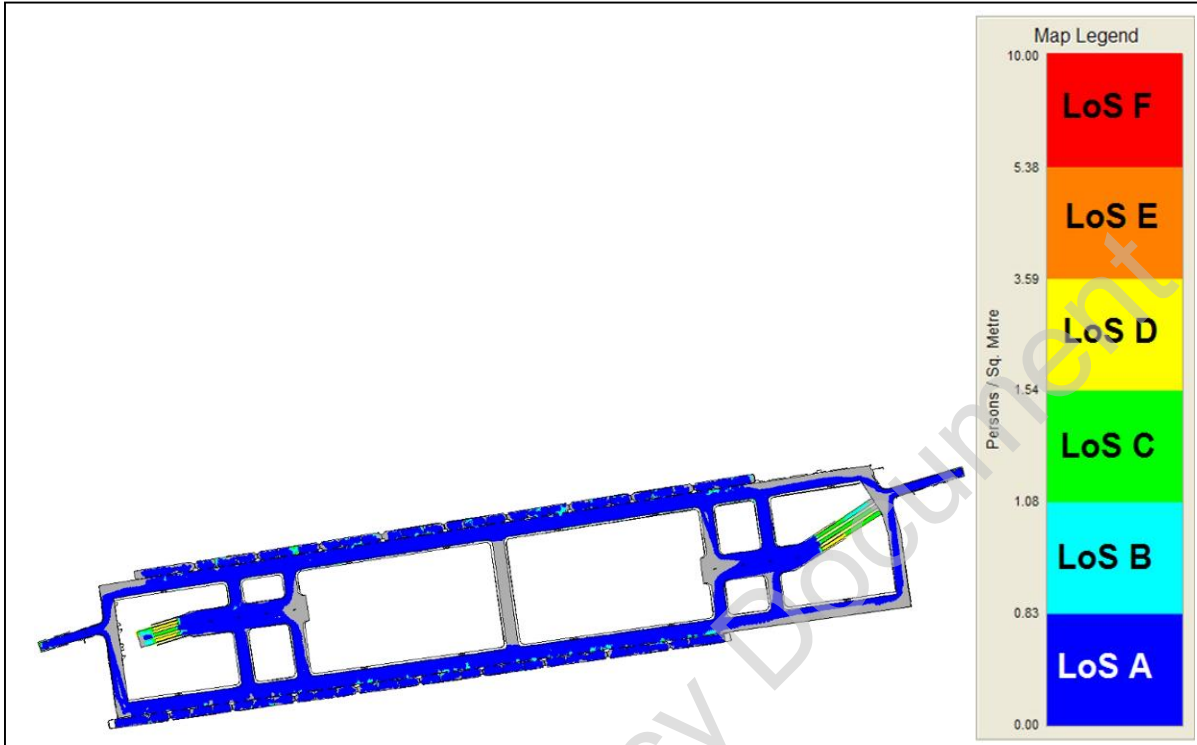
**PM Peak 2026 Stage E Design Platform Level  
 Cumulative High Density (18:00-18:15)**



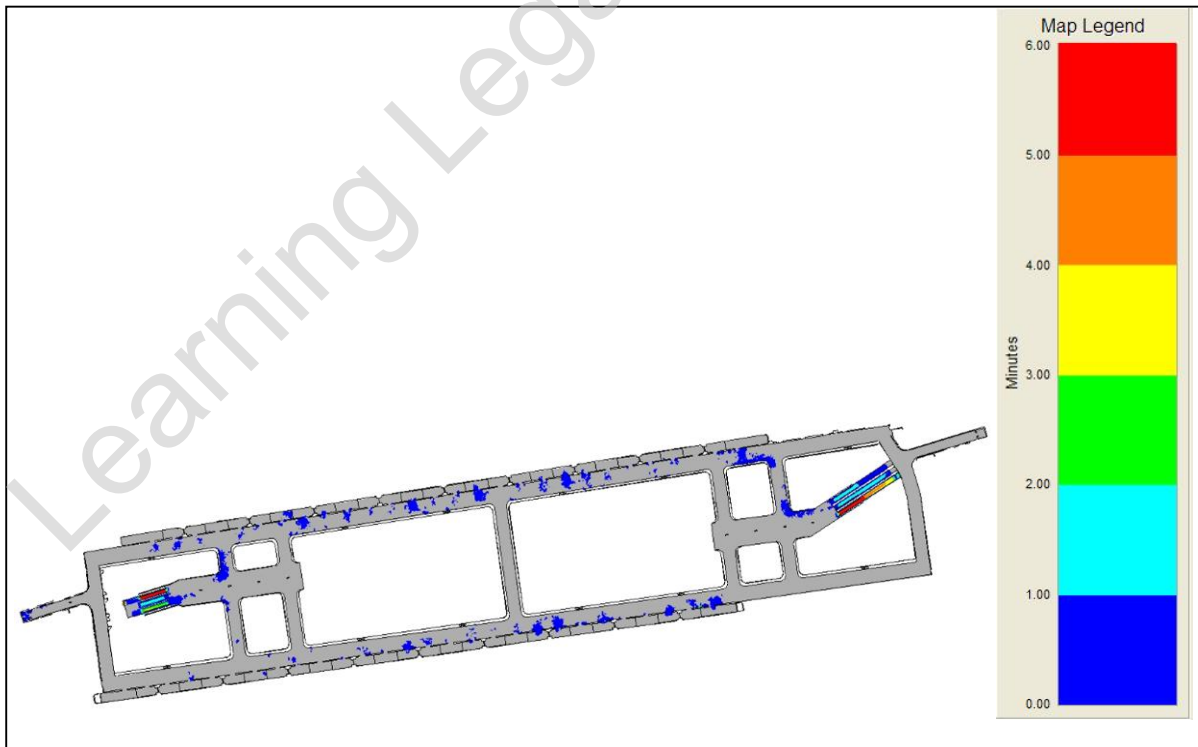
**PM Peak 2026 Stage E Design Platform Level  
 Cumulative Mean Density Walking (18:15-18:30)**



**PM Peak 2026 Stage E Design Platform Level  
 Cumulative Mean Density Queuing (18:15-18:30)**



**PM Peak 2026 Stage E Design Platform Level  
 Cumulative High (18:15-18:30)**



## Appendix H – PM 2026+28% Density Maps

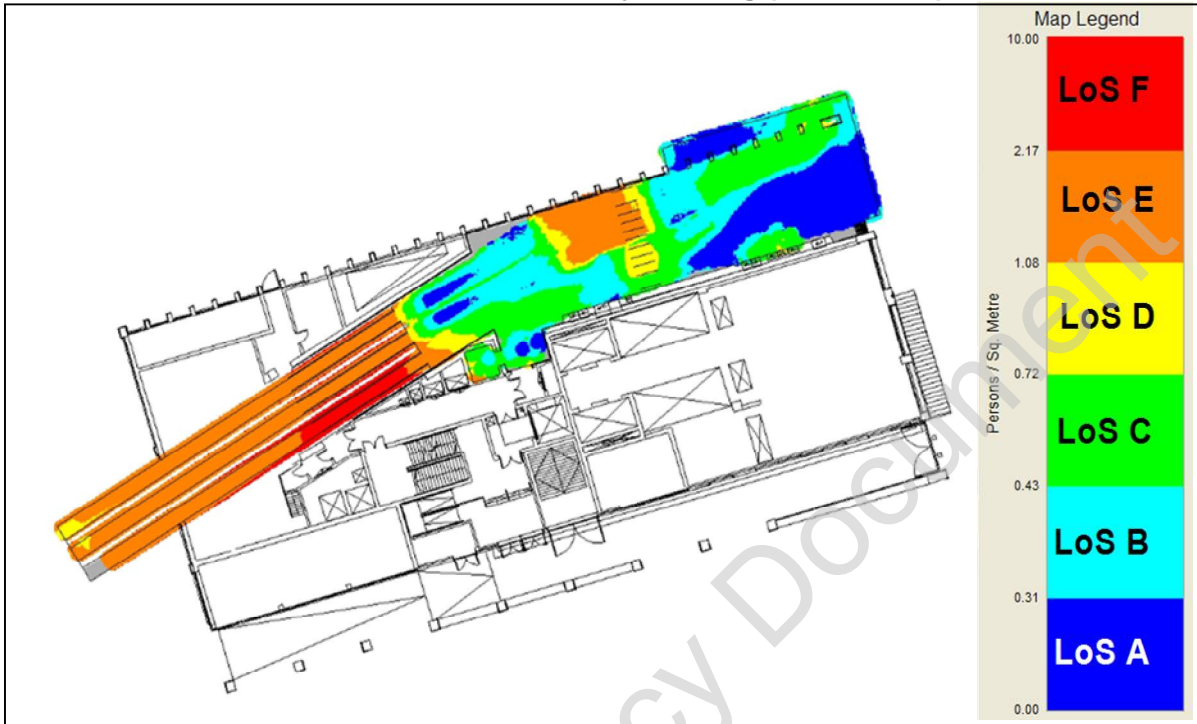
Cumulative Mean Density (CMD) maps provide the average density conditions that occur within the peak 15 minutes these are presented in 15 minute segments for the peak hour (17:30-18:30).

Cumulative High Density Maps (CHD) maps shows how long various areas of a site have registered densities greater than 1.54 passengers/sq.metre (LoS D for queuing). The range of colours represent time, in 1 minute intervals (up to 6 minutes). The map is similar to a 'temperature' map: areas that have experienced high levels of density for a long time appear red; those that have experienced shorter periods of density appear blue.

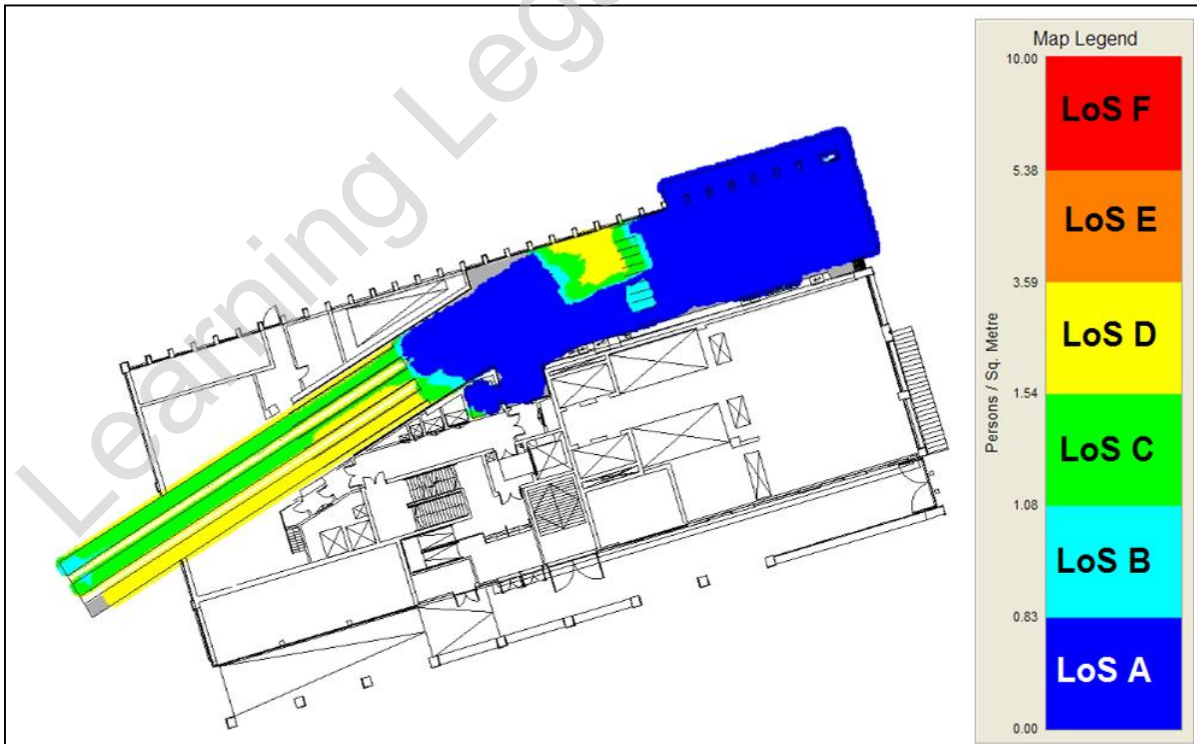
Learning Legacy Document

Hanover Square Ticket Hall

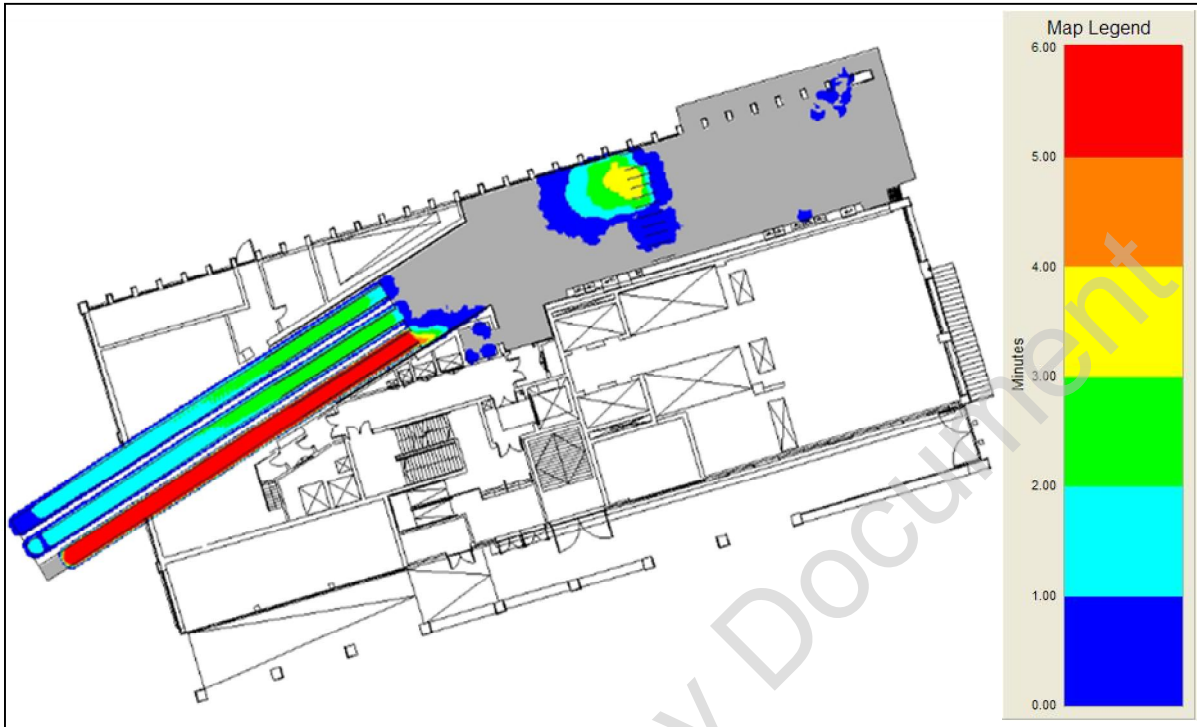
PM Peak 2026+28% Stage E Design Hanover Square Ticket Hall  
 Cumulative Mean Density Walking (17:30-17:45)



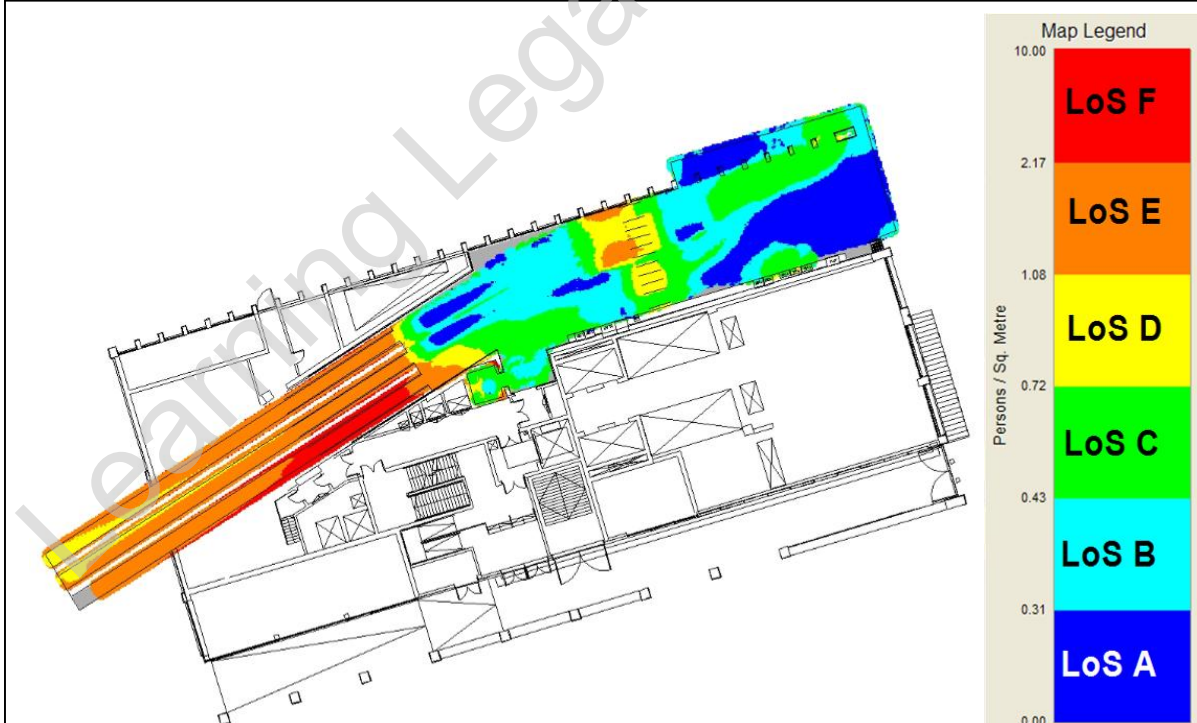
PM Peak 2026+28% Stage E Design Hanover Square Ticket Hall  
 Cumulative Mean Density Queuing (17:30-17:45)



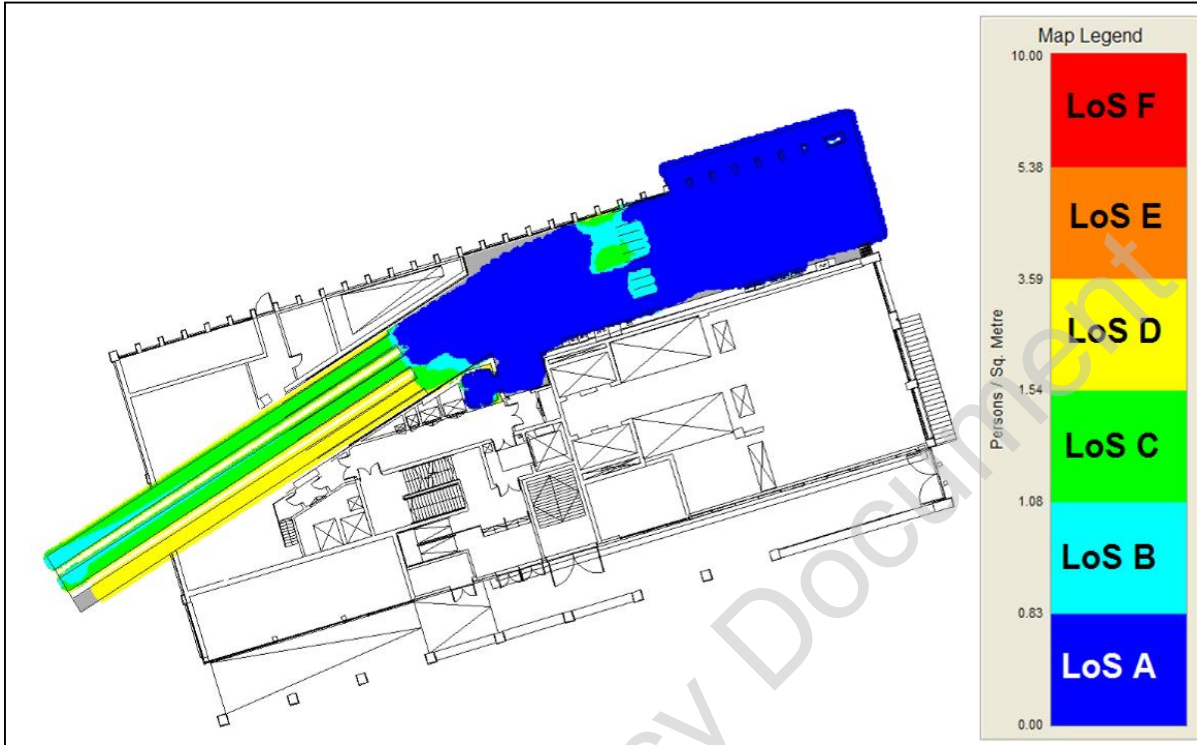
**PM Peak 2026+28% Stage E Design Hanover Square Ticket Hall  
 Cumulative High Density (17:30-17:45)**



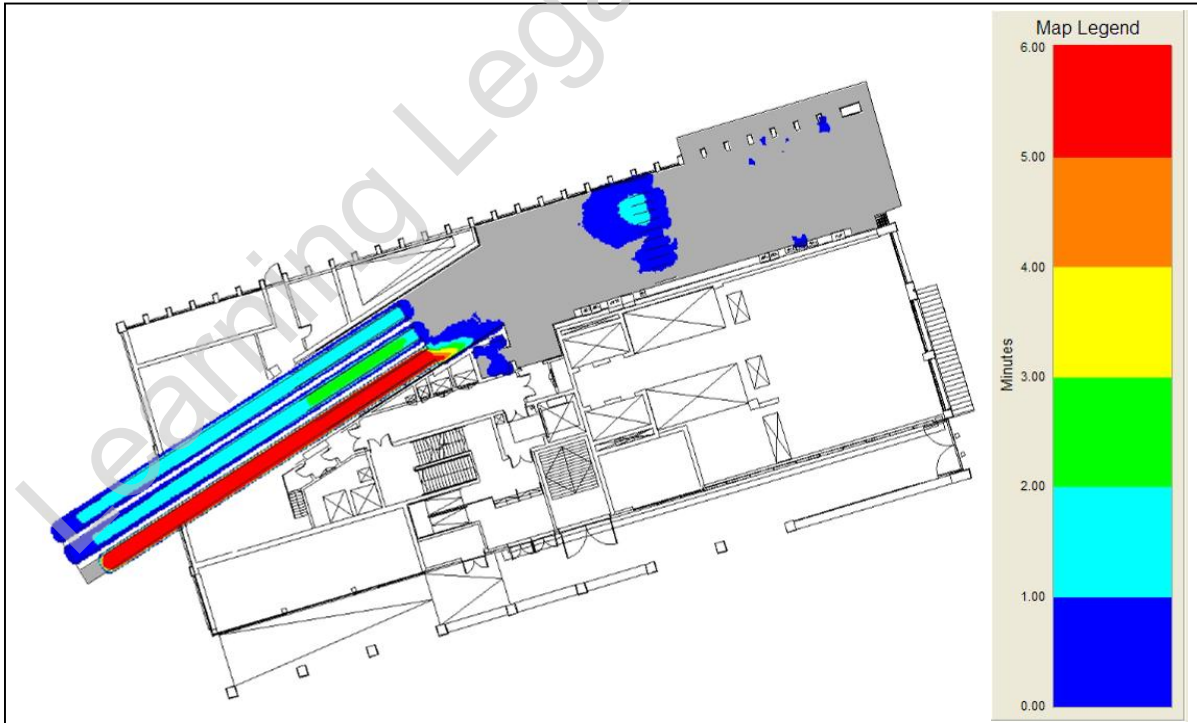
**PM Peak 2026+28% Stage E Design Hanover Square Ticket Hall  
 Cumulative Mean Density Walking (17:45-18:00)**



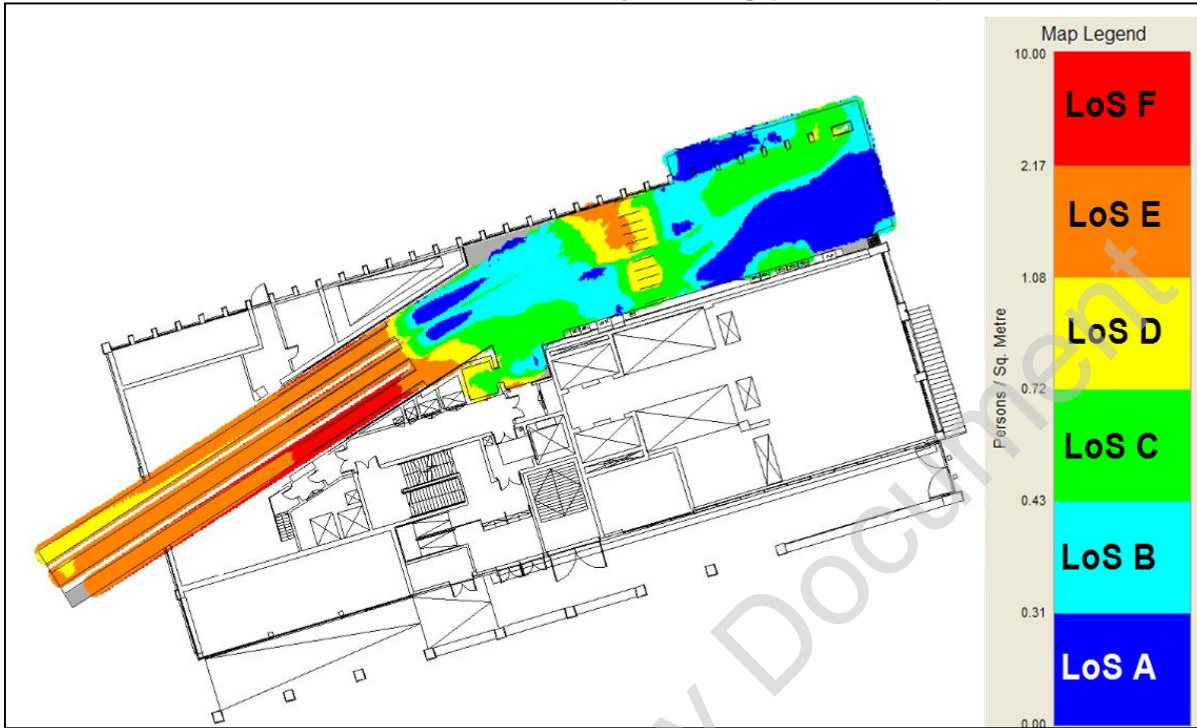
**PM Peak 2026+28% Stage E Design Hanover Square Ticket Hall  
 Cumulative Mean Density Queuing (17:45-18:00)**



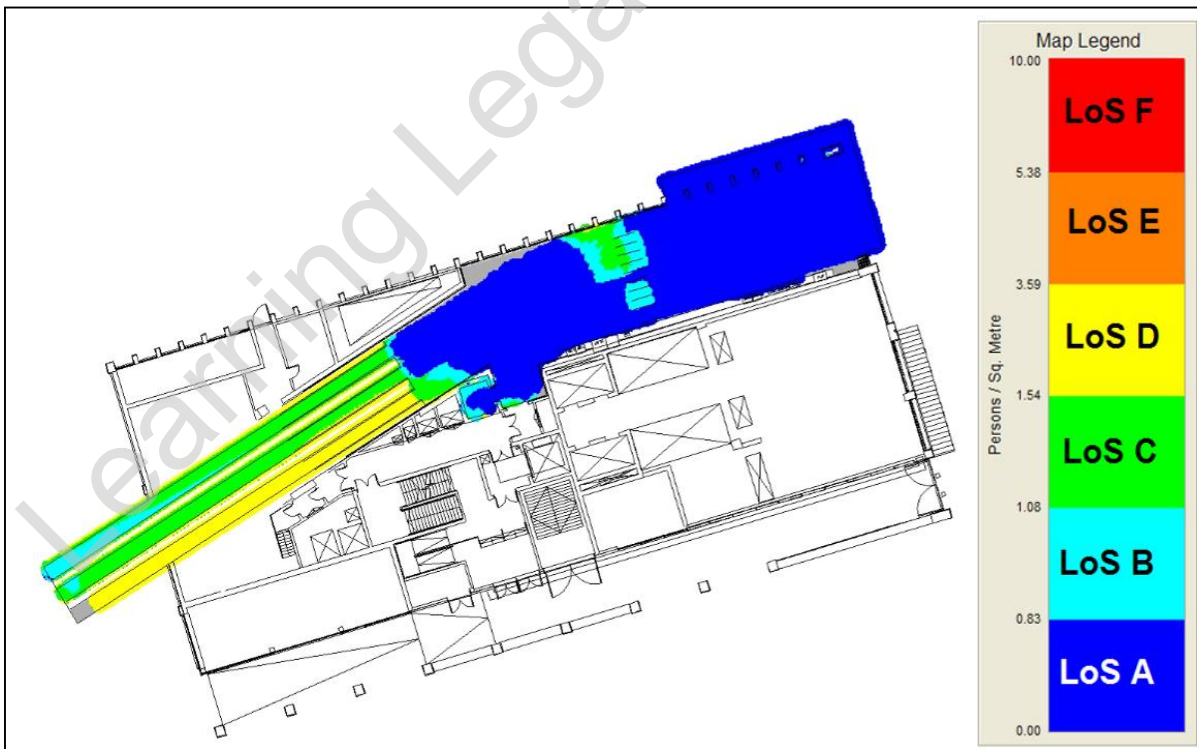
**PM Peak 2026+28% Stage E Design Hanover Square Ticket Hall  
 Cumulative High Density (17:45-18:00)**



**PM Peak 2026+28% Stage E Design Hanover Square Ticket Hall  
 Cumulative Mean Density Walking (18:00-18:15)**

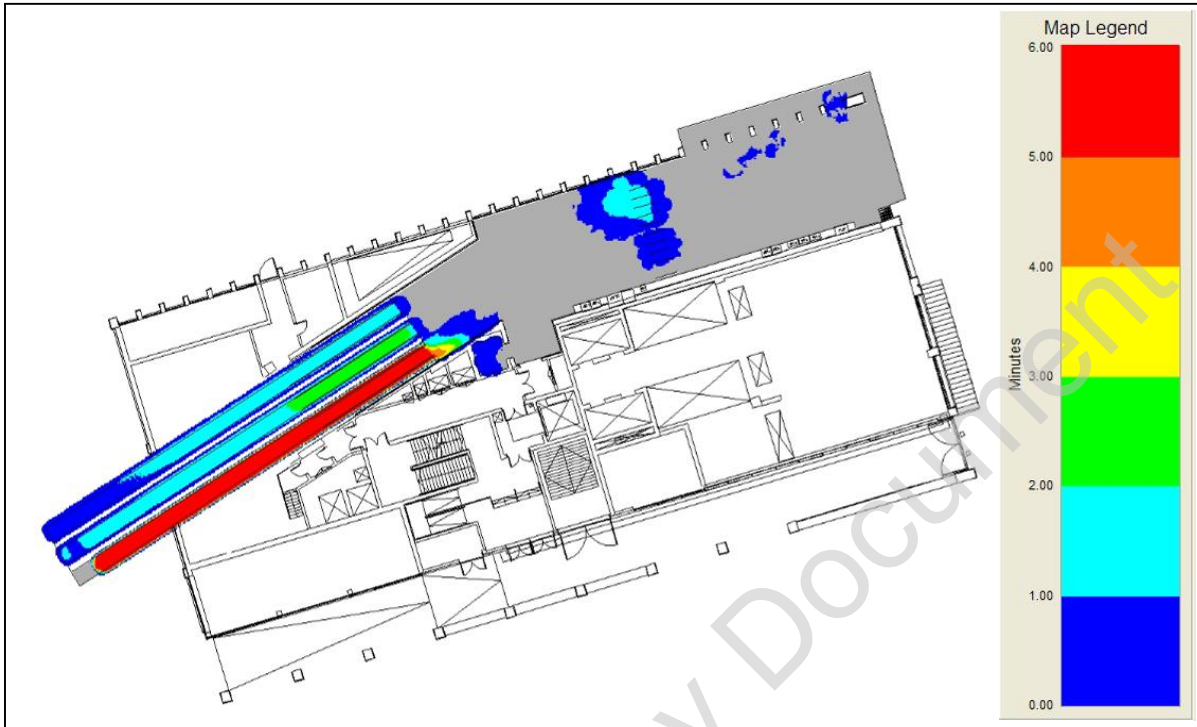


**PM Peak 2026+28% Stage E Design Hanover Square Ticket Hall  
 Cumulative Mean Density Queuing (18:00-18:15)**

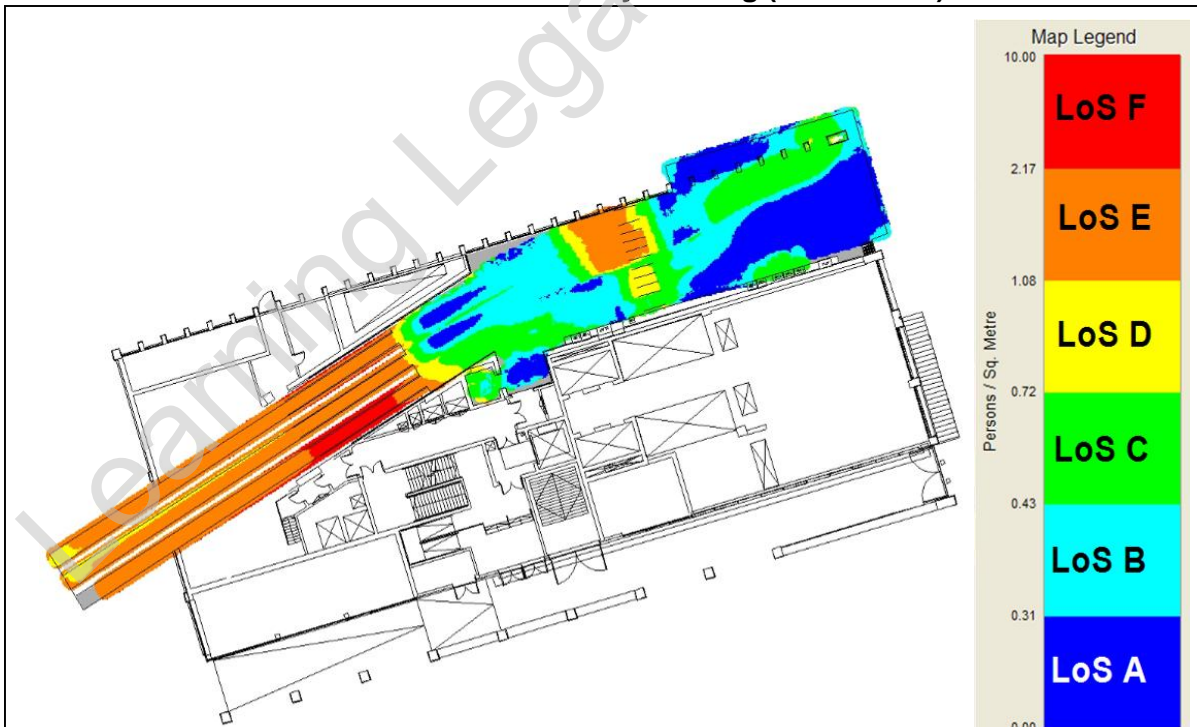




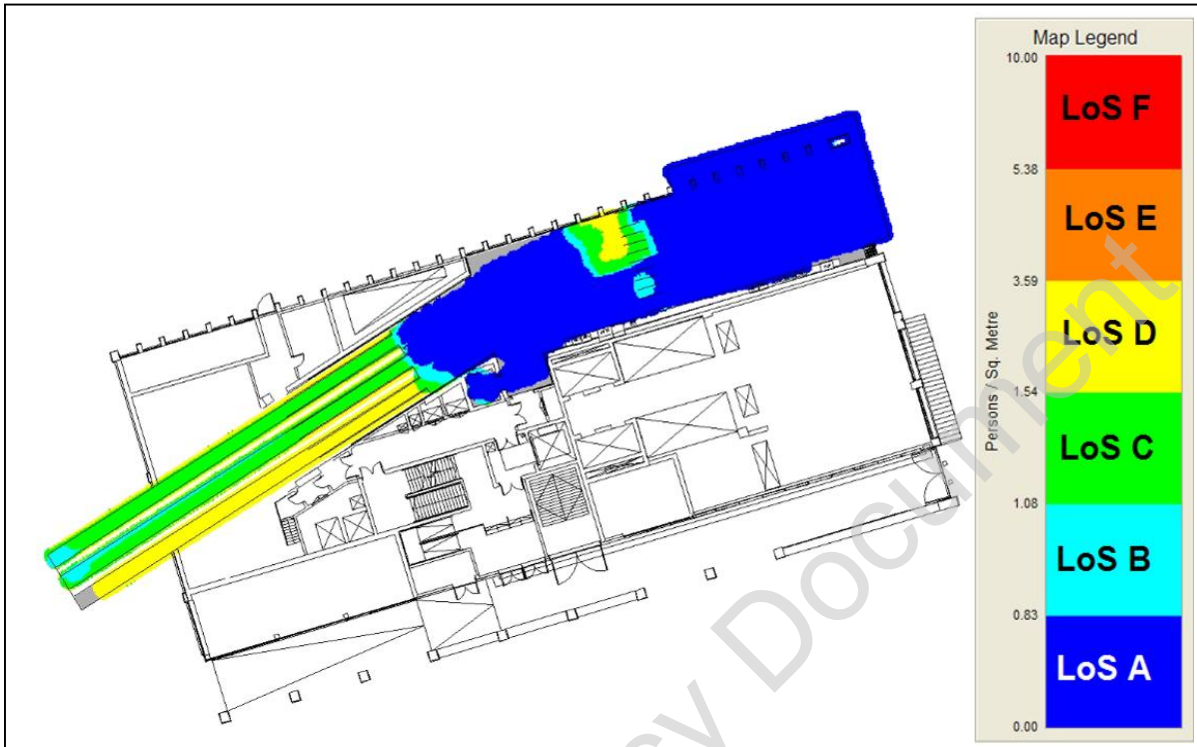
**PM Peak 2026+28% Stage E Design Hanover Square Ticket Hall  
 Cumulative High Density (18:00-18:15)**



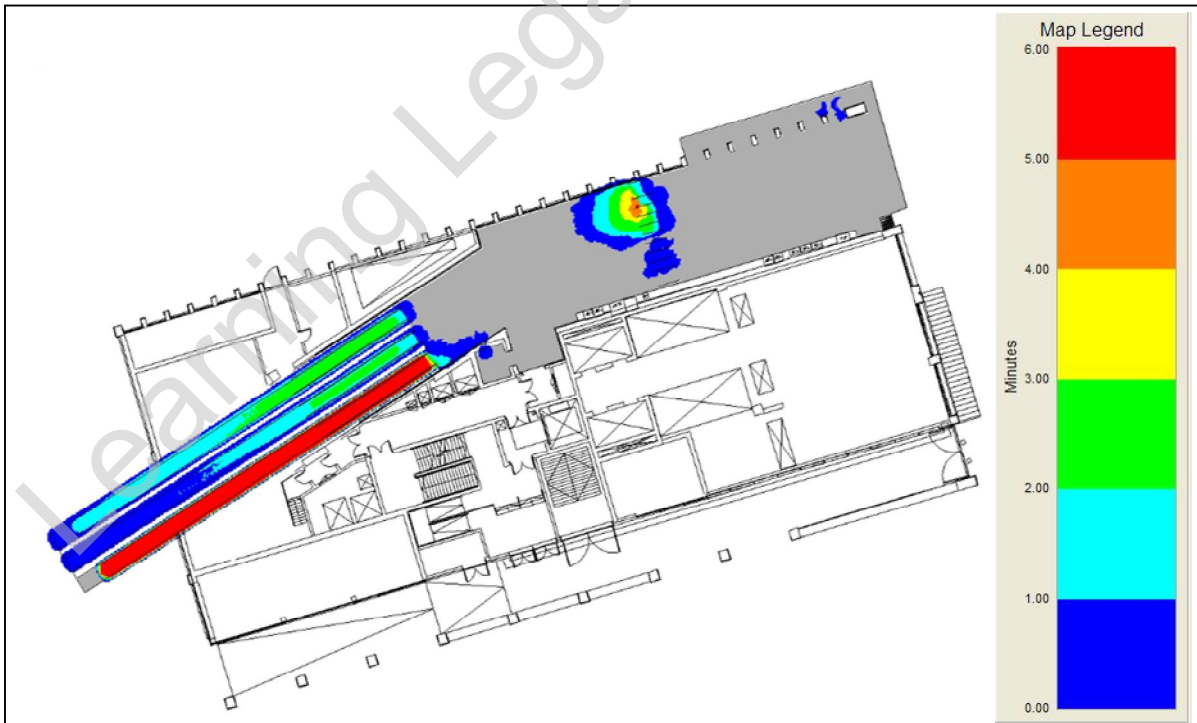
**PM Peak 2026+28% Stage E Design Hanover Square Ticket Hall  
 Cumulative Mean Density Walking (18:15-18:30)**



**PM Peak 2026+28% Stage E Design Hanover Square Ticket Hall  
 Cumulative Mean Density Queuing (18:15-18:30)**

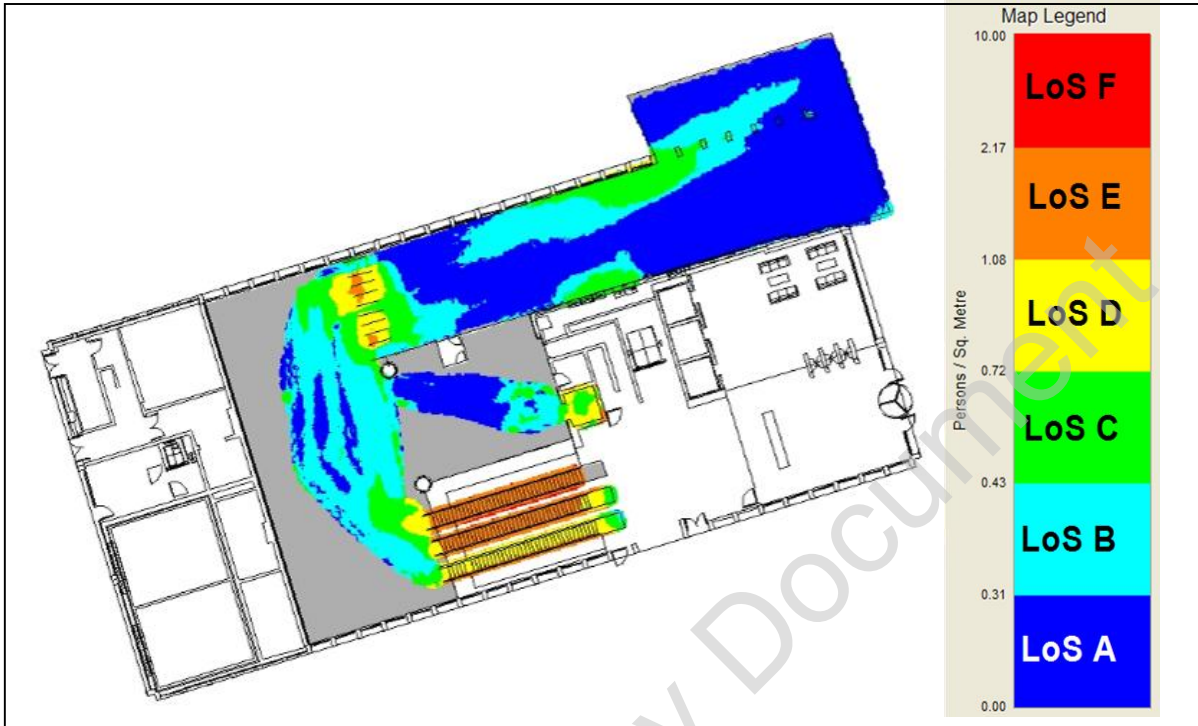


**PM Peak 2026+28% Stage E Design Hanover Square Ticket Hall  
 Cumulative High (18:15-18:30)**

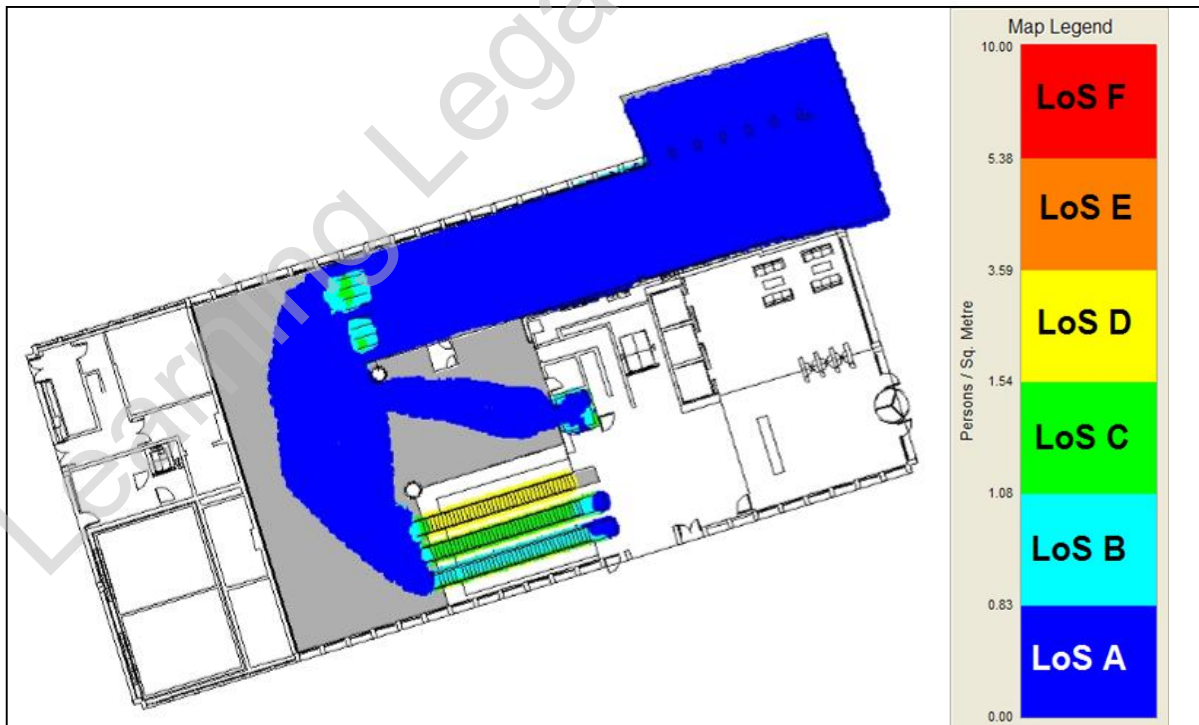


Davies Street Ticket Hall

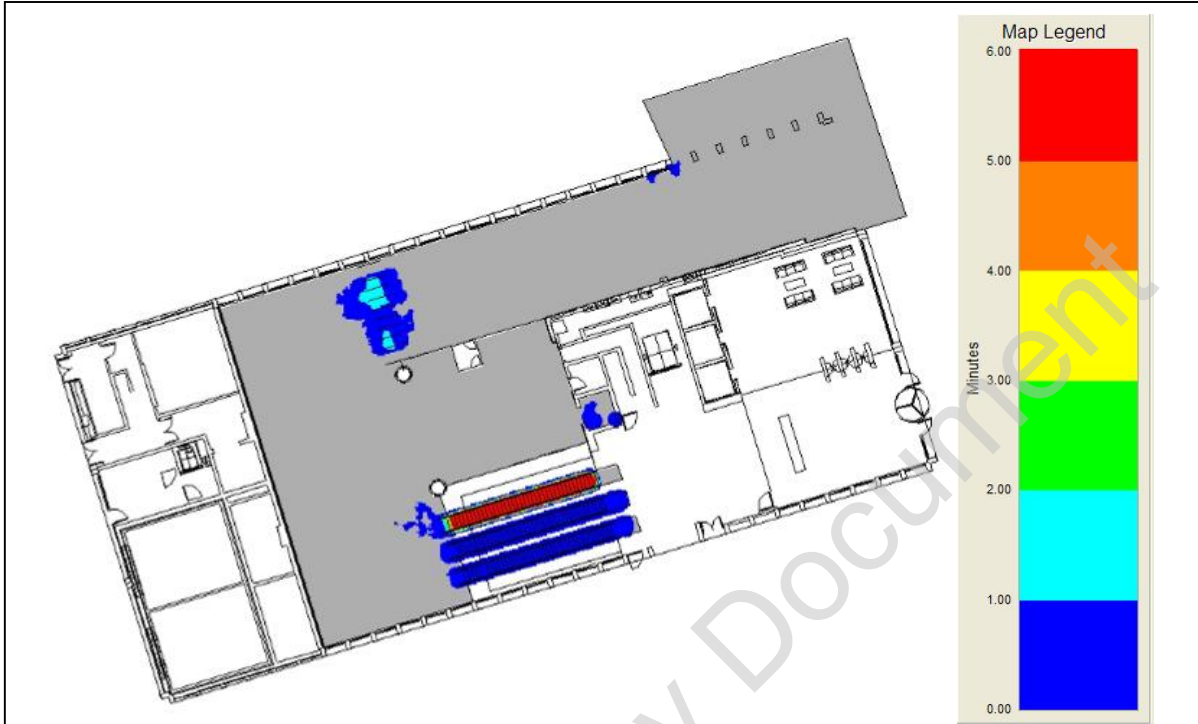
**PM Peak 2026+28% Stage E Design Davies Street Ticket Hall  
Cumulative Mean Density Walking (17:30-17:45)**



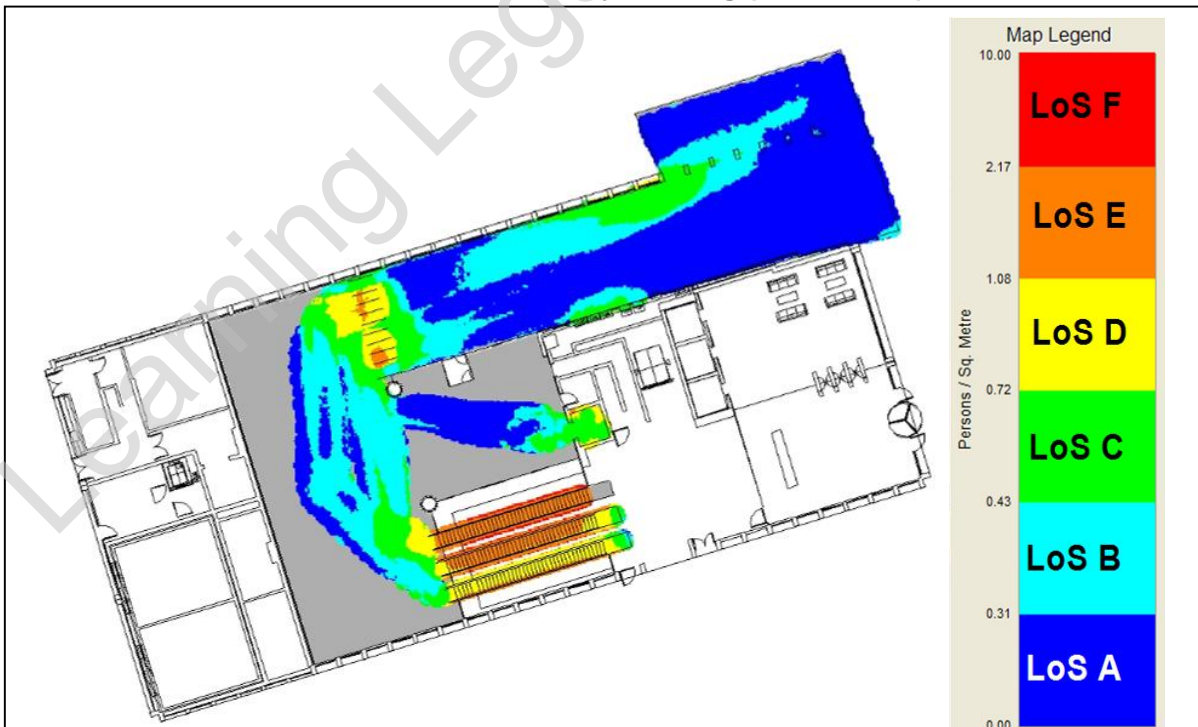
**PM Peak 2026+28% Stage E Design Davies Street Ticket Hall  
Cumulative Mean Density Queuing (17:30-17:45)**



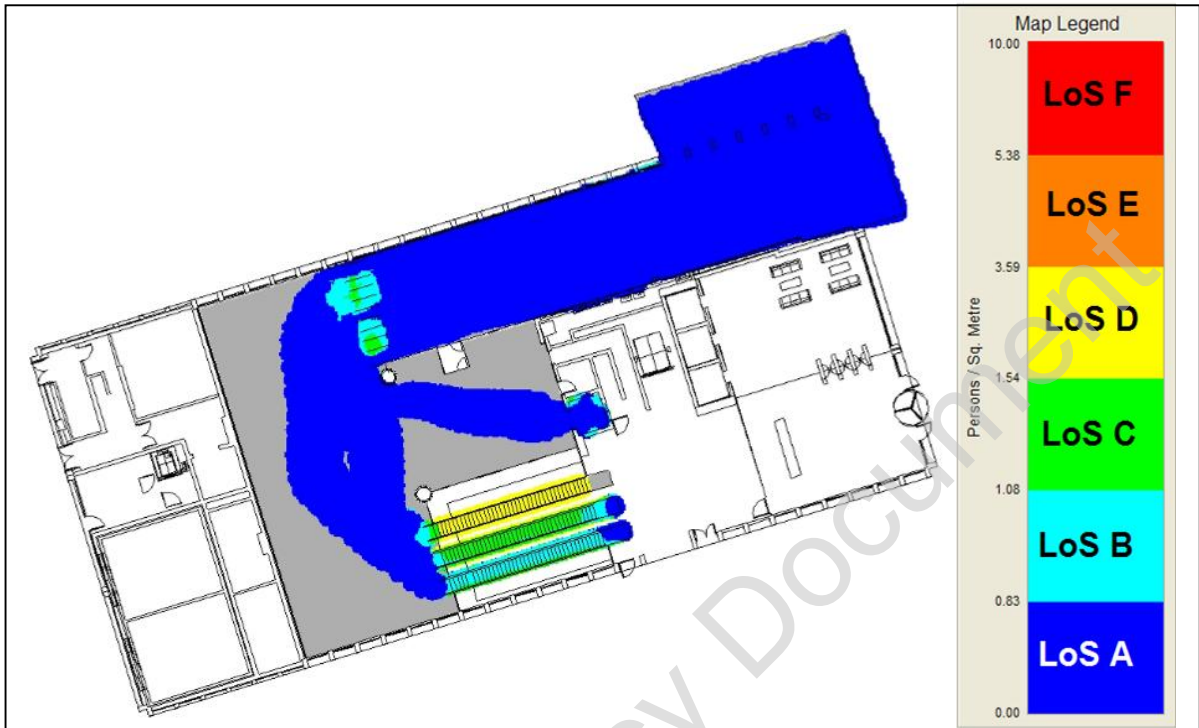
**PM Peak 2026+28% Stage E Design Davies Street Ticket Hall  
Cumulative High Density (17:30-17:45)**



**PM Peak 2026+28% Stage E Design Davies Street Ticket Hall  
Cumulative Mean Density Walking (17:45-18:00)**



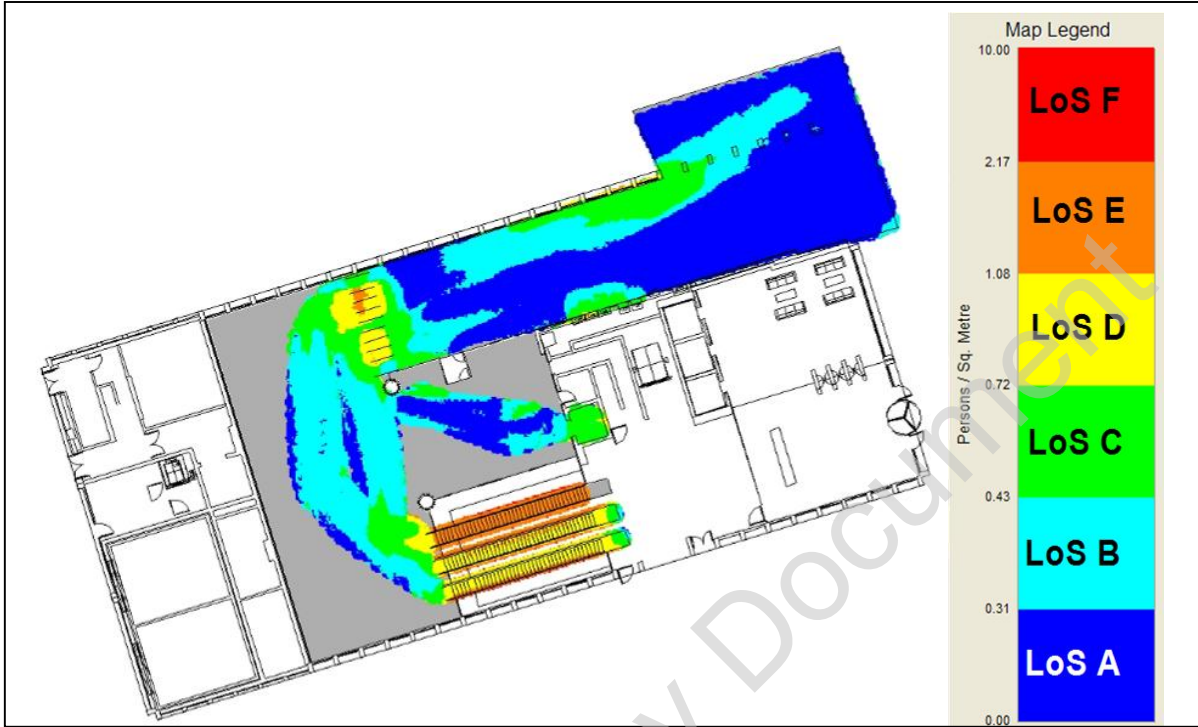
**PM Peak 2026+28% Stage E Design Davies Street Ticket Hall  
Cumulative Mean Density Queuing (17:45-18:00)**



**PM Peak 2026+28% Stage E Design Davies Street Ticket Hall  
Cumulative High Density (17:45-18:00)**



**PM Peak 2026+28% Stage E Design Davies Street Ticket Hall  
 Cumulative Mean Density Walking (18:00-18:15)**



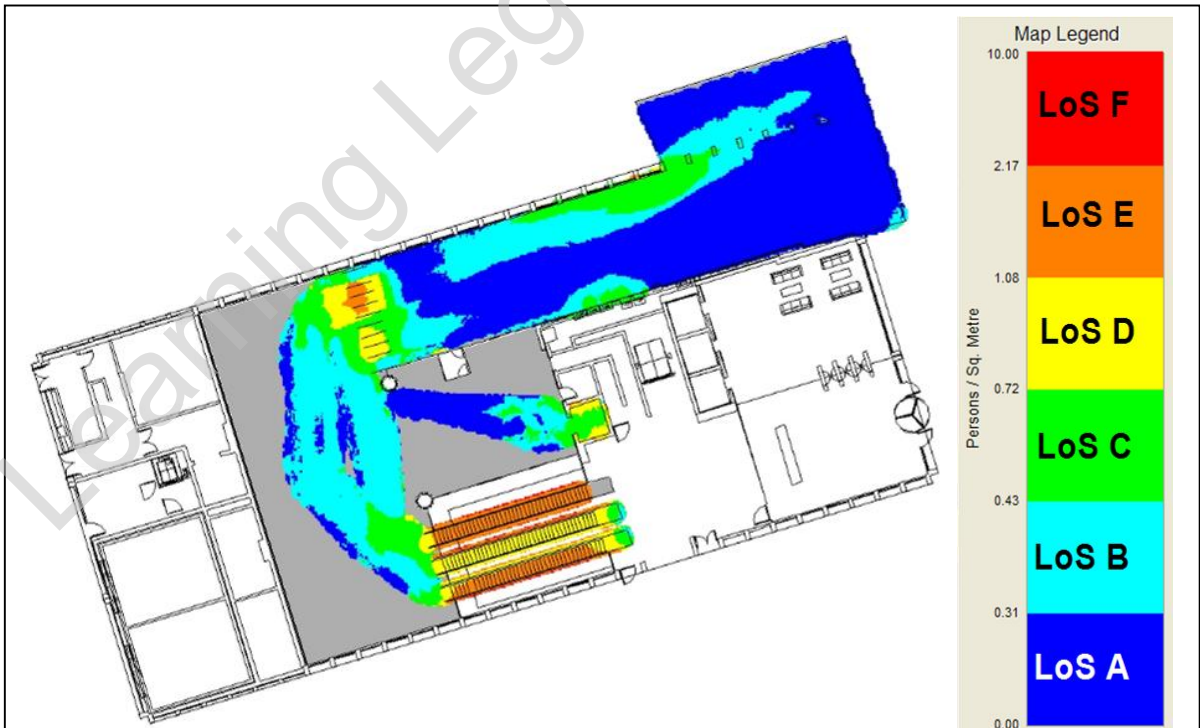
**PM Peak 2026+28% Stage E Design Davies Street Ticket Hall  
 Cumulative Mean Density Queuing (18:00-18:15)**



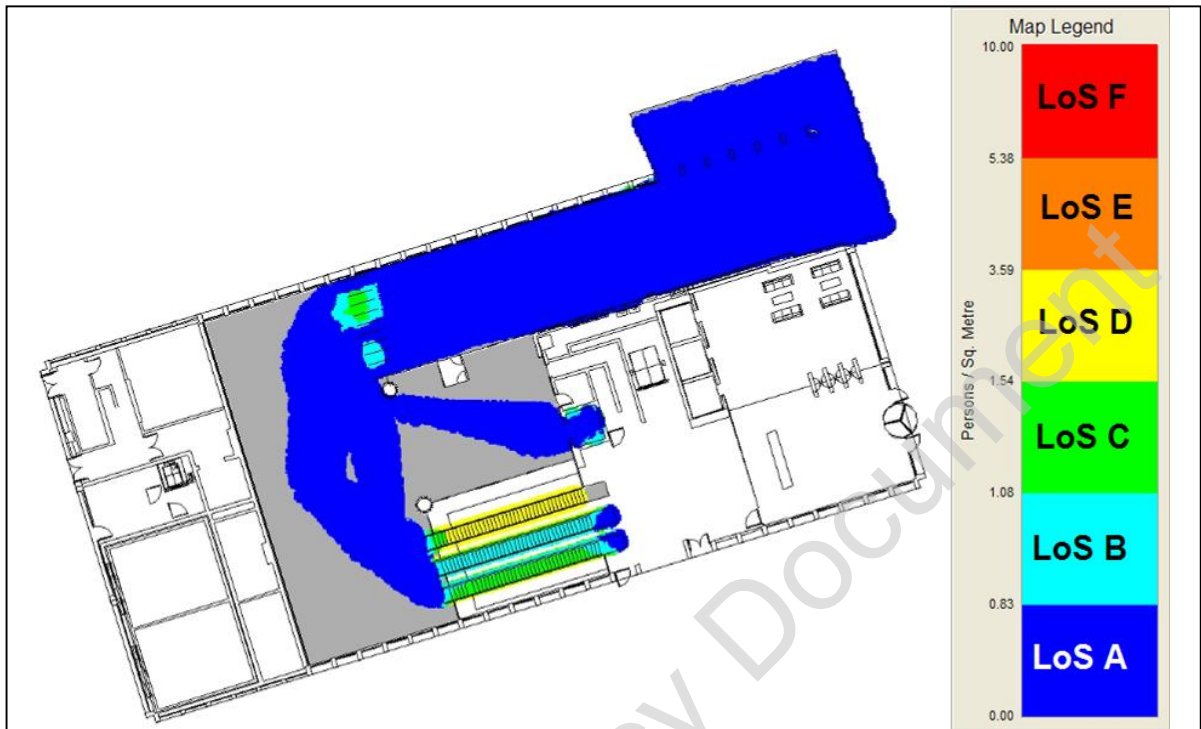
**PM Peak 2026+28% Stage E Design Davies Street Ticket Hall  
 Cumulative High Density (18:00-18:15)**



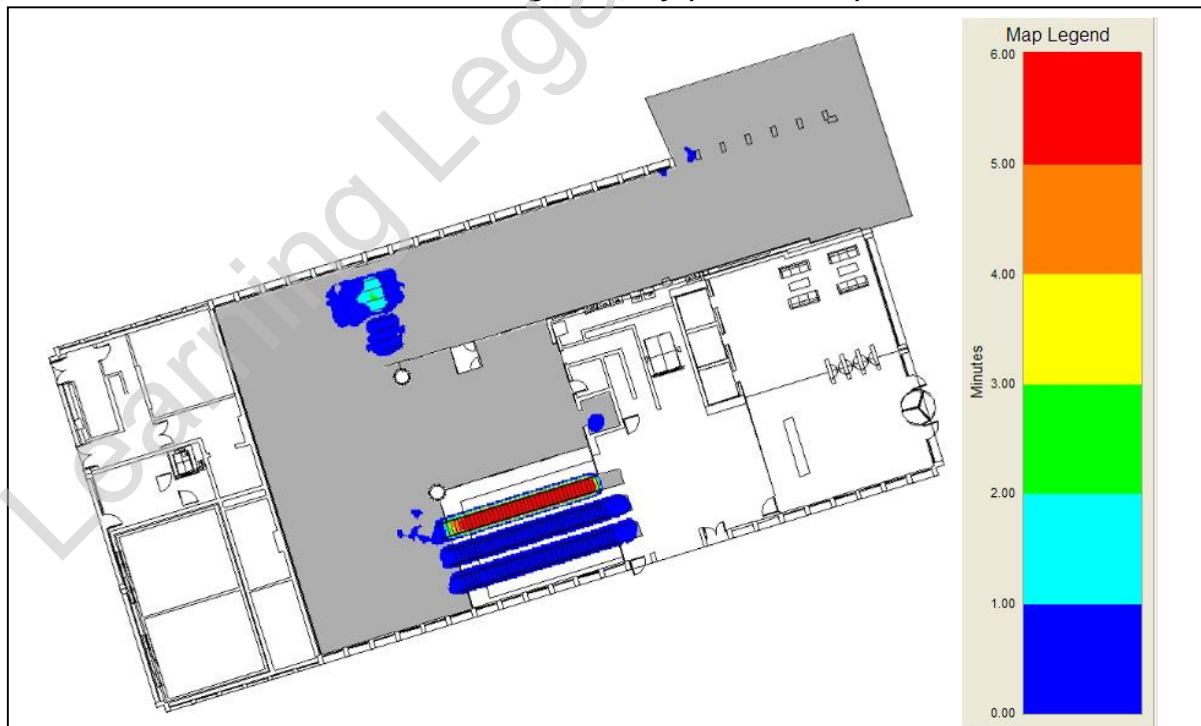
**PM Peak 2026+28% Stage E Design Davies Street Ticket Hall  
 Cumulative Mean Density Walking (18:15-18:30)**



**PM Peak 2026+28% Stage E Design Davies Street Ticket Hall  
 Cumulative Mean Density Queuing (18:15-18:30)**



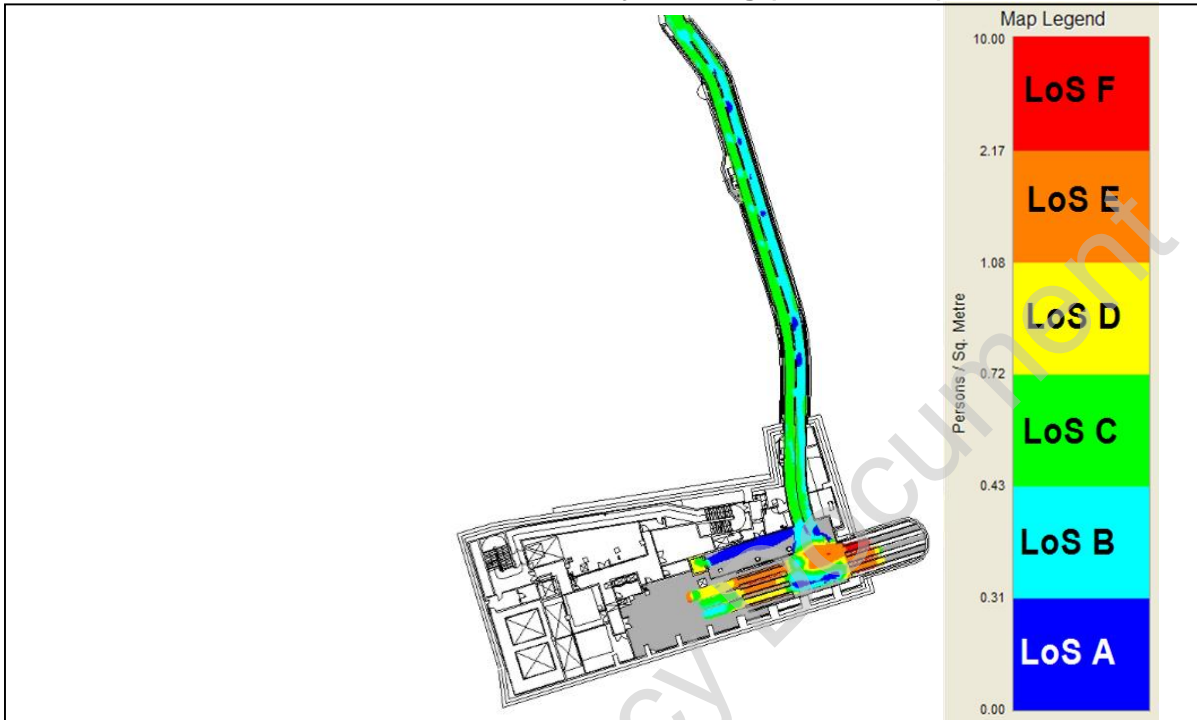
**PM Peak 2026+28% Stage E Design Davies Street Ticket Hall  
 Cumulative High Density (18:15-18:30)**



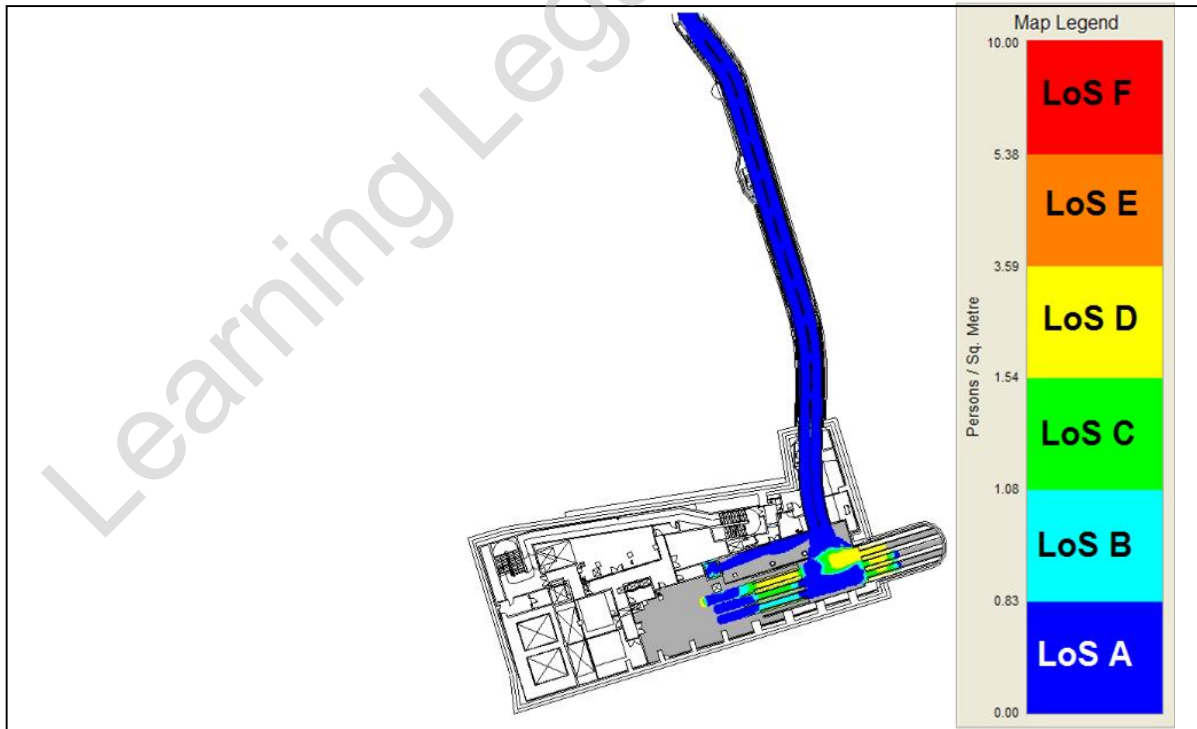


Intermediate Level

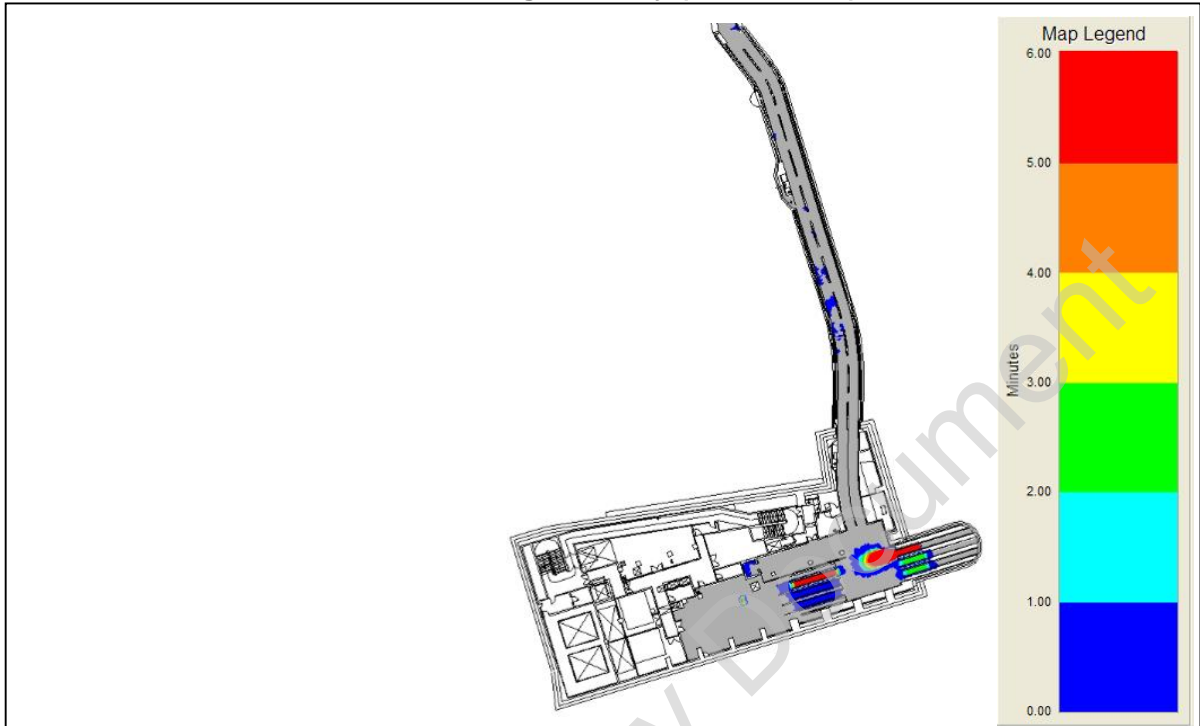
PM Peak 2026+28% Stage E Design Intermediate Level  
 Cumulative Mean Density Walking (17:30-17:45)



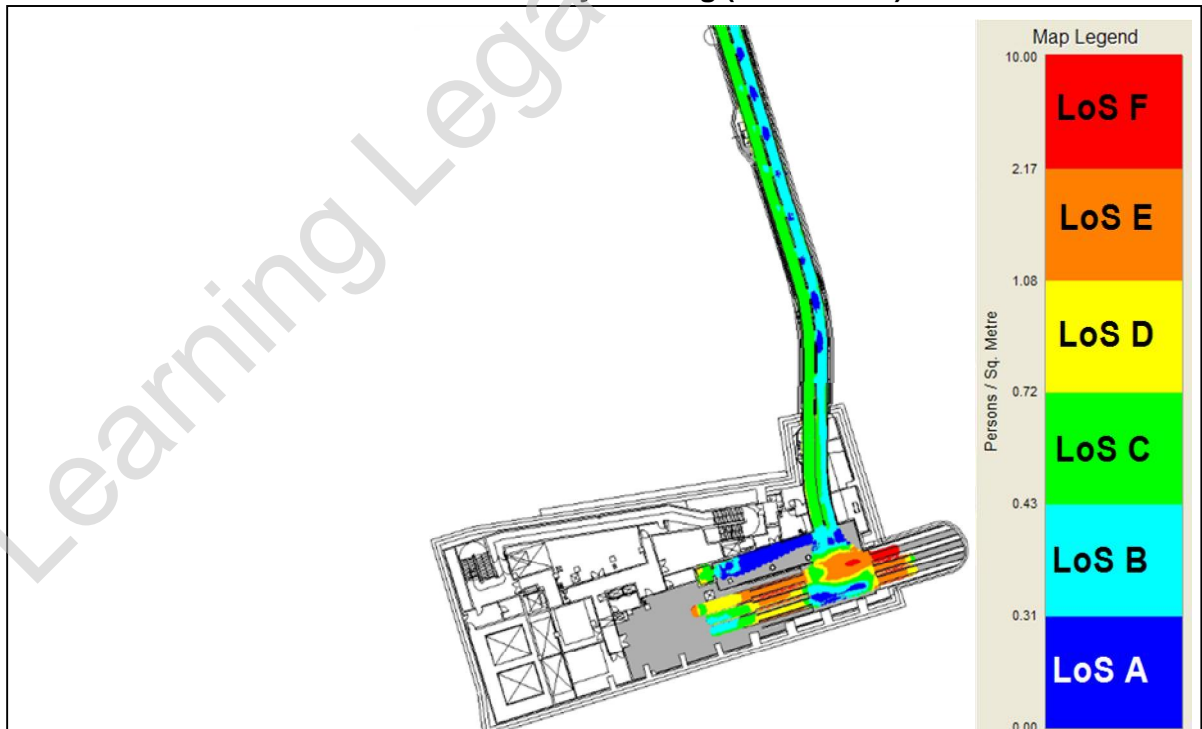
PM Peak 2026+28% Stage E Design Intermediate Level  
 Cumulative Mean Density Queuing (17:30-17:45)



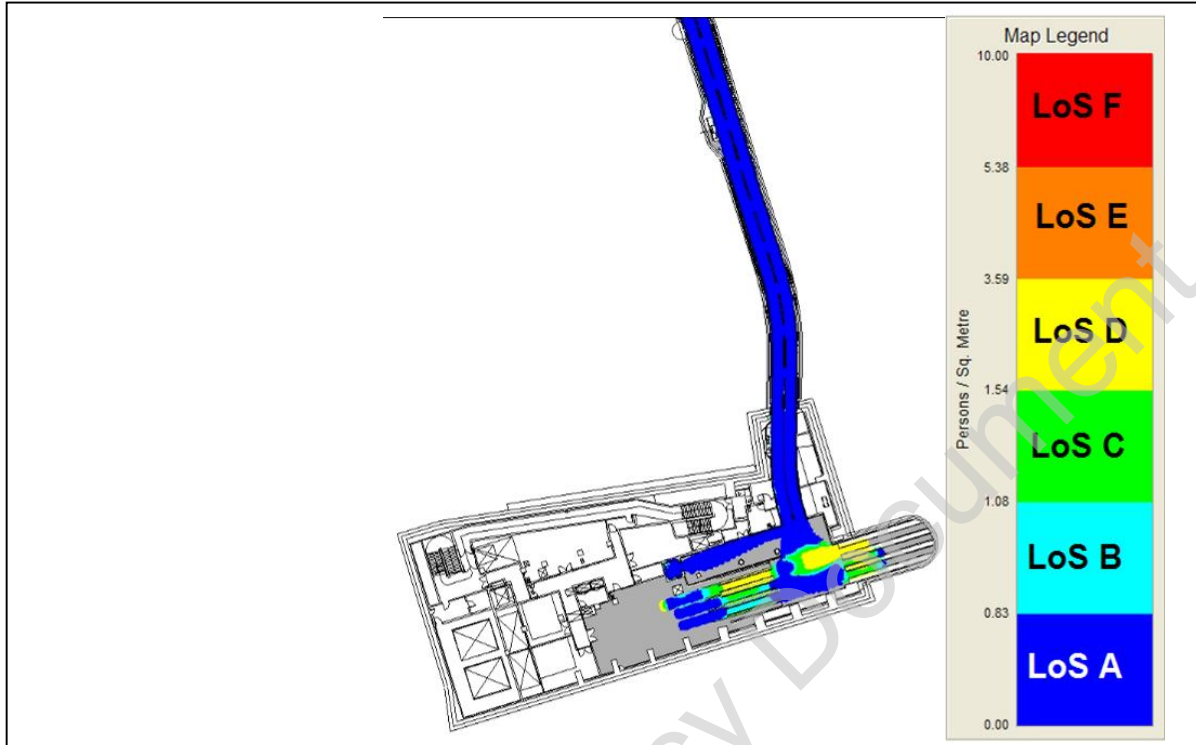
**PM Peak 2026+28% Stage E Design Intermediate Level  
 Cumulative High Density (17:30-17:45)**



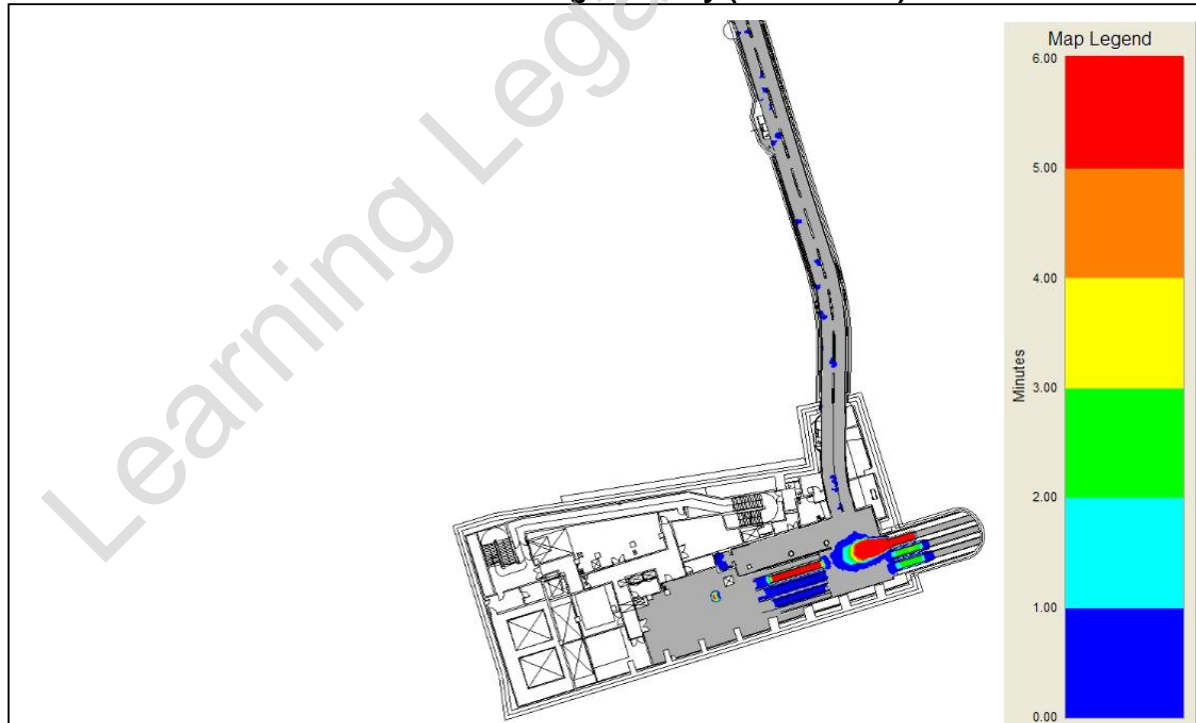
**PM Peak 2026+28% Stage E Design Intermediate Level  
 Cumulative Mean Density Walking (17:45-18:00)**



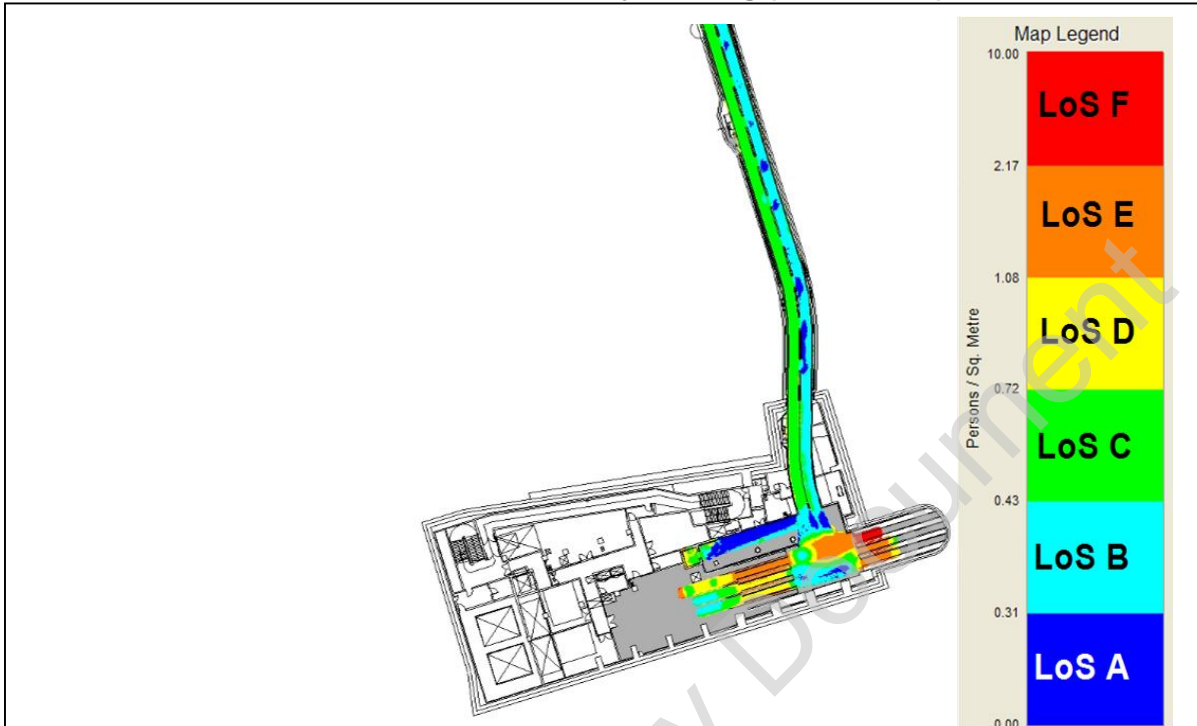
**PM Peak 2026+28% Stage E Design Intermediate Level  
 Cumulative Mean Density Queuing (17:45-18:00)**



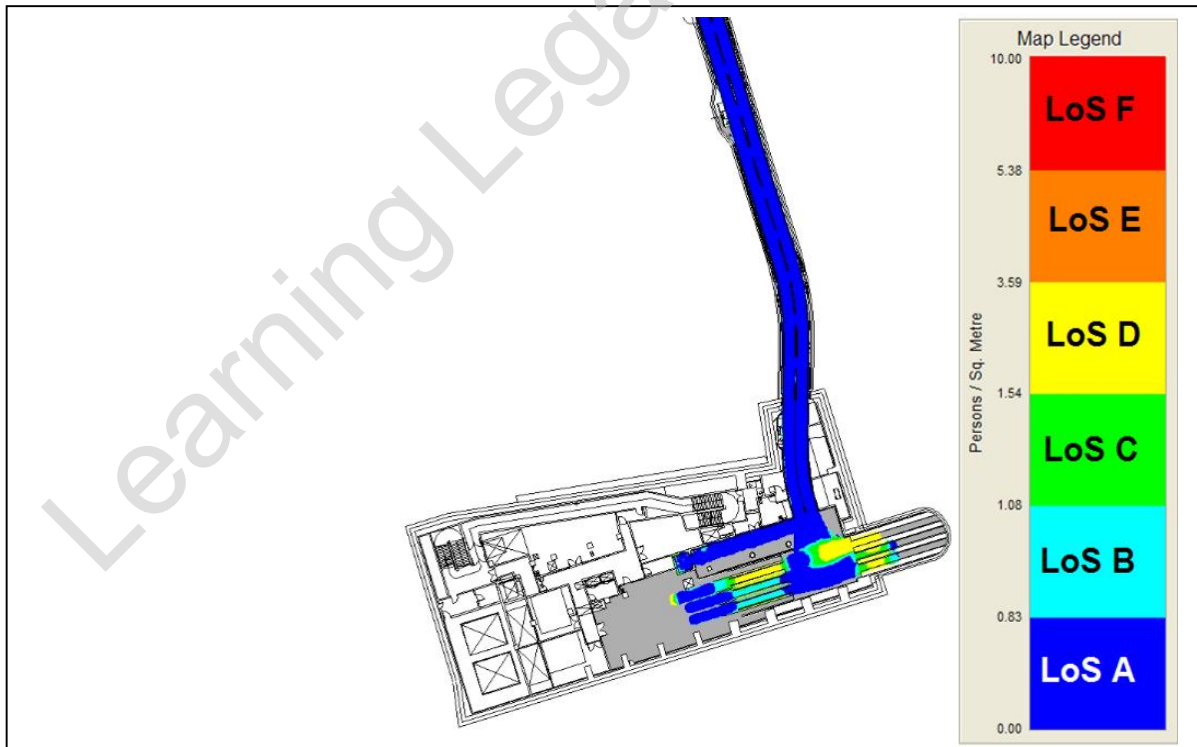
**PM Peak 2026+28% Stage E Design Intermediate Level  
 Cumulative High Density (17:45-18:00)**



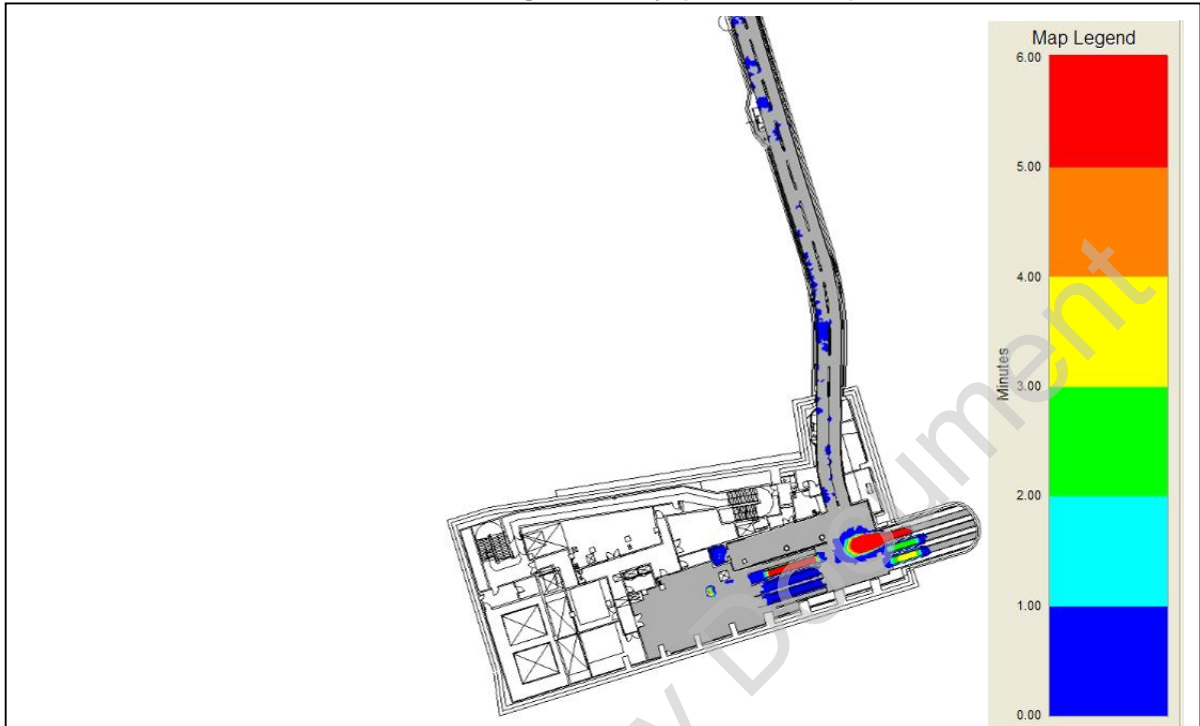
**PM Peak 2026+28% Stage E Design Intermediate Level  
 Cumulative Mean Density Walking (18:00-18:15)**



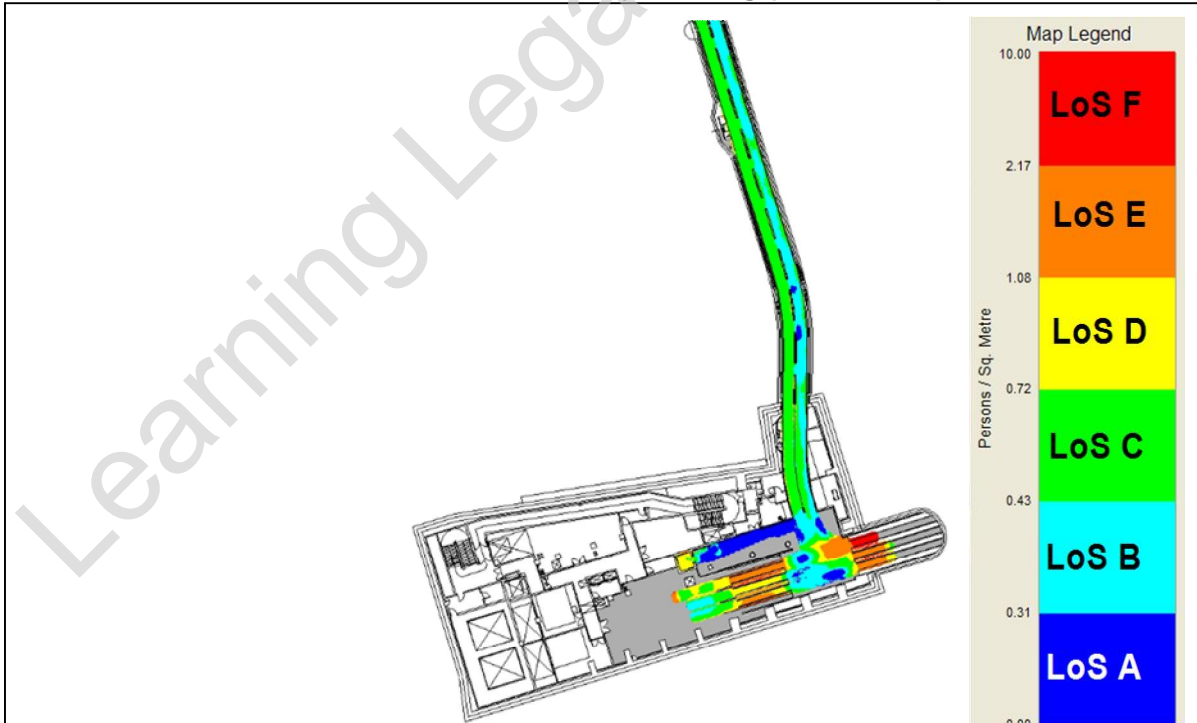
**PM Peak 2026+28% Stage E Design Intermediate Level  
 Cumulative Mean Density Queuing (18:00-18:15)**



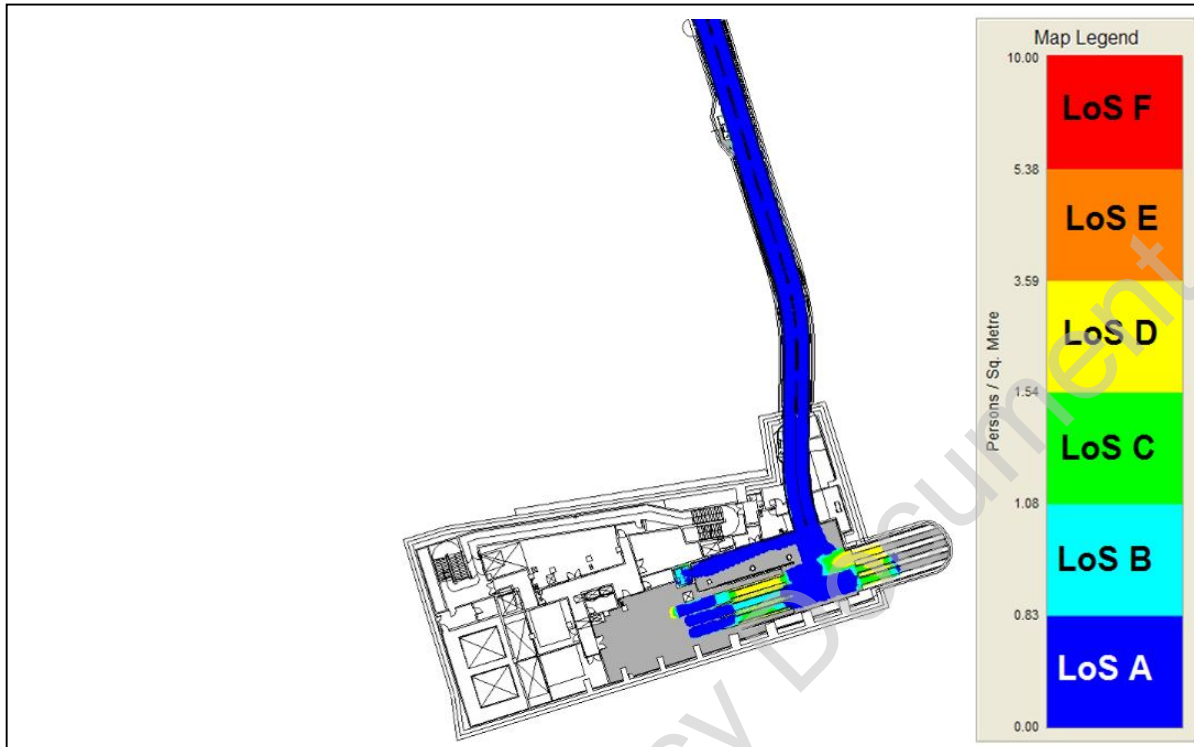
**PM Peak 2026+28% Stage E Design Intermediate Level  
 Cumulative High Density (18:00-18:15)**



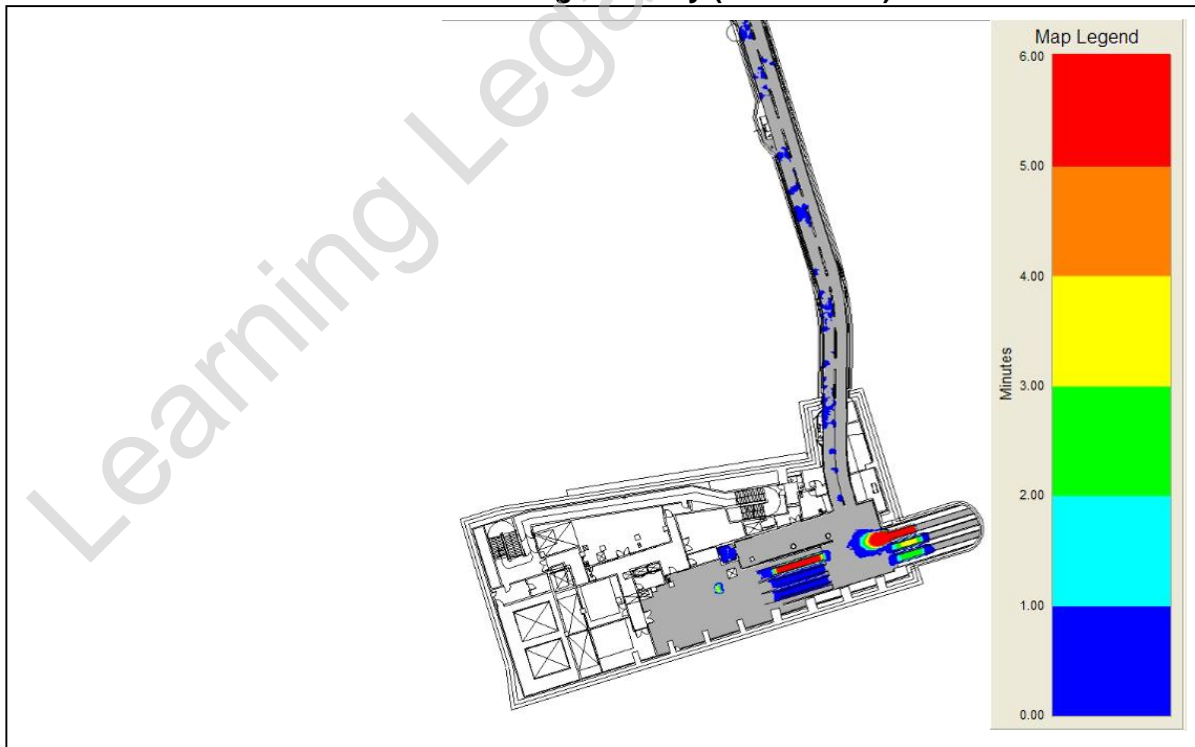
**PM Peak 2026+28% Stage E Design Intermediate Level  
 Cumulative Mean Density Walking (18:15-18:30)**



**PM Peak 2026+28% Stage E Design Intermediate Level  
 Cumulative Mean Density Queuing (18:15-18:30)**

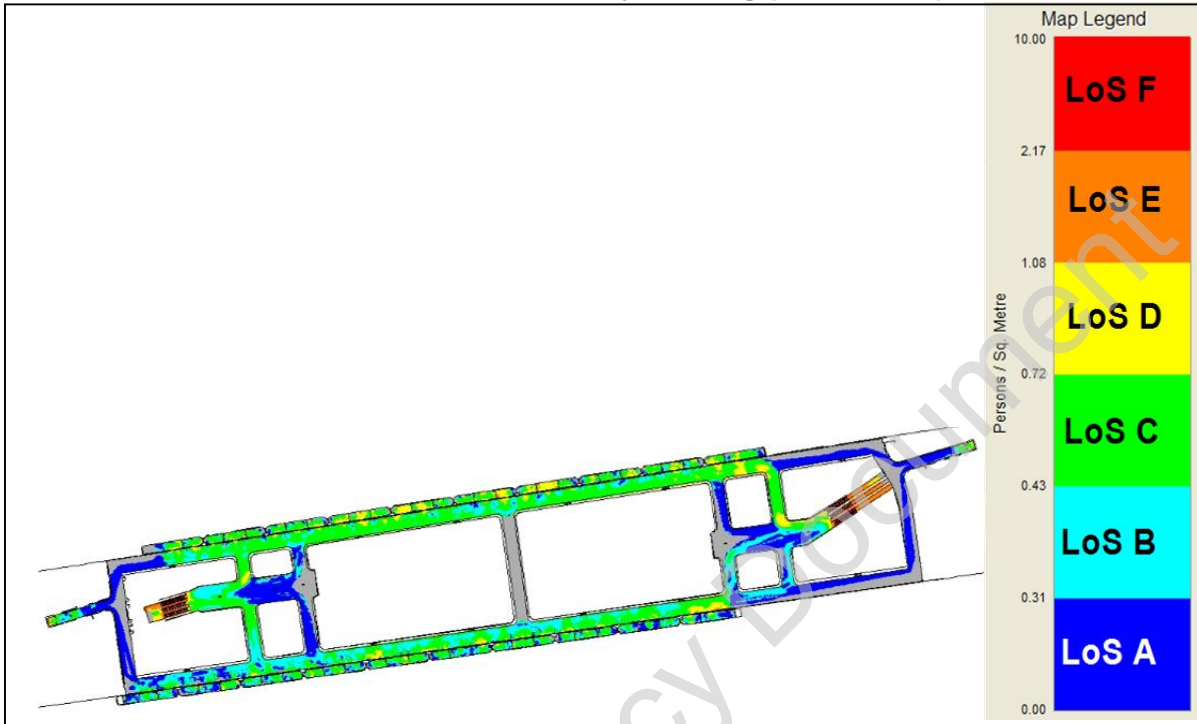


**PM Peak 2026+28% Stage E Design Intermediate Level  
 Cumulative High Density (18:15-18:30)**

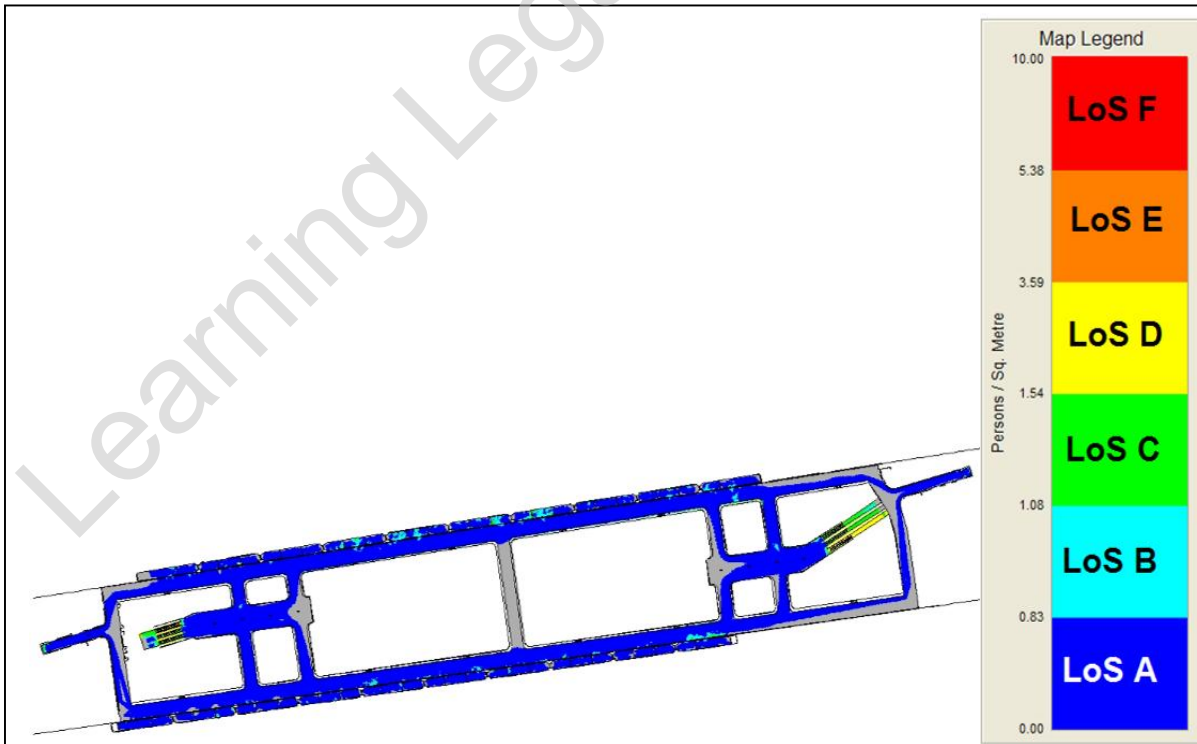


Platform Level

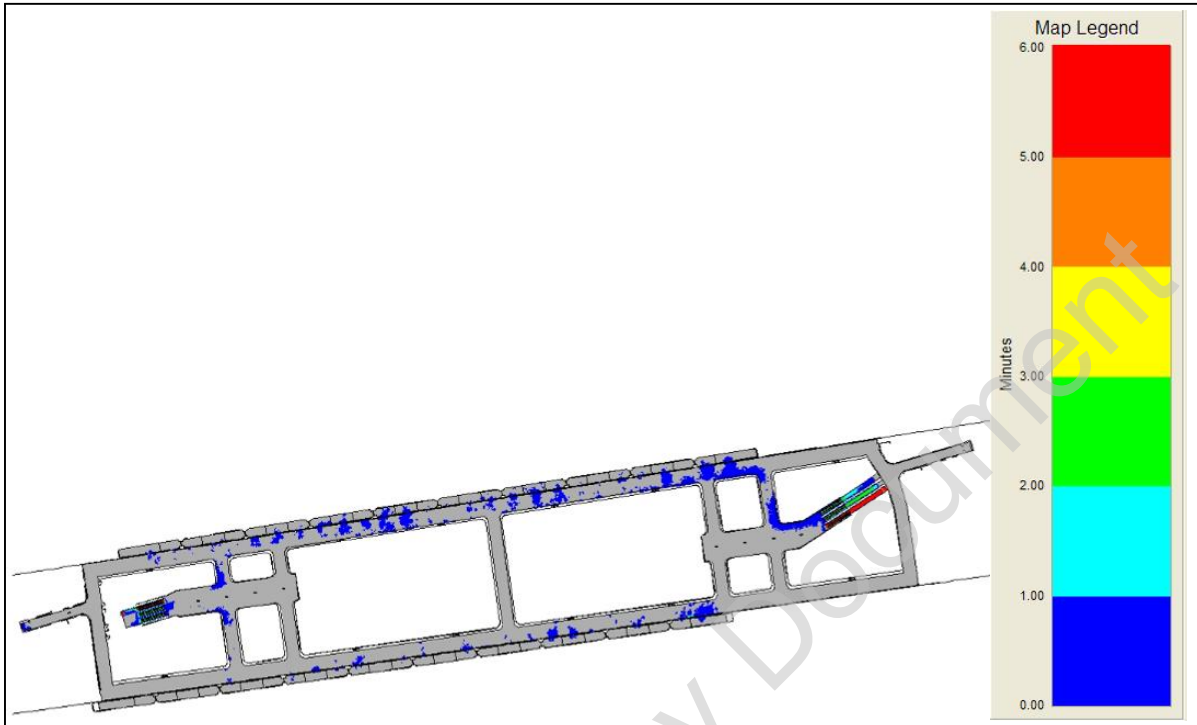
PM Peak 2026+28% Stage E Design Platform Level  
 Cumulative Mean Density Walking (17:30-17:45)



PM Peak 2026+28% Stage E Design Platform Level  
 Cumulative Mean Density Queuing (17:30-17:45)



**PM Peak 2026+28% Stage E Design Platform Level  
 Cumulative High Density (17:30-17:45)**



**PM Peak 2026+28% Stage E Design Platform Level  
 Cumulative Mean Density Walking (17:45-18:00)**

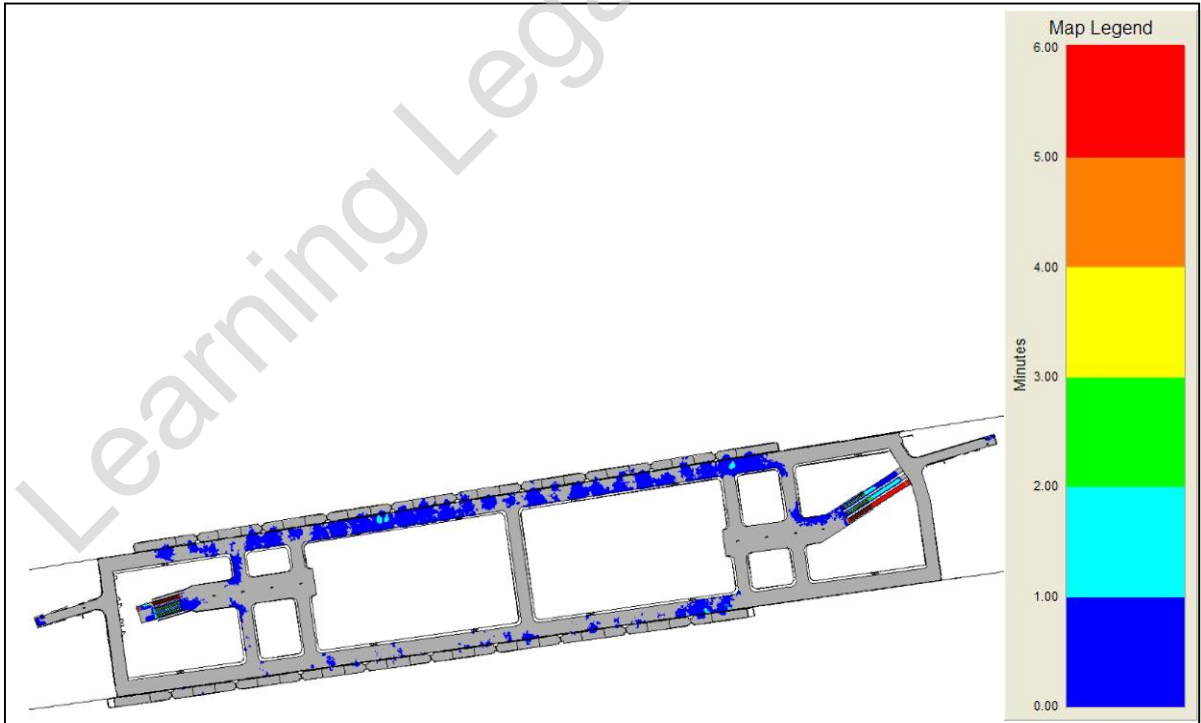




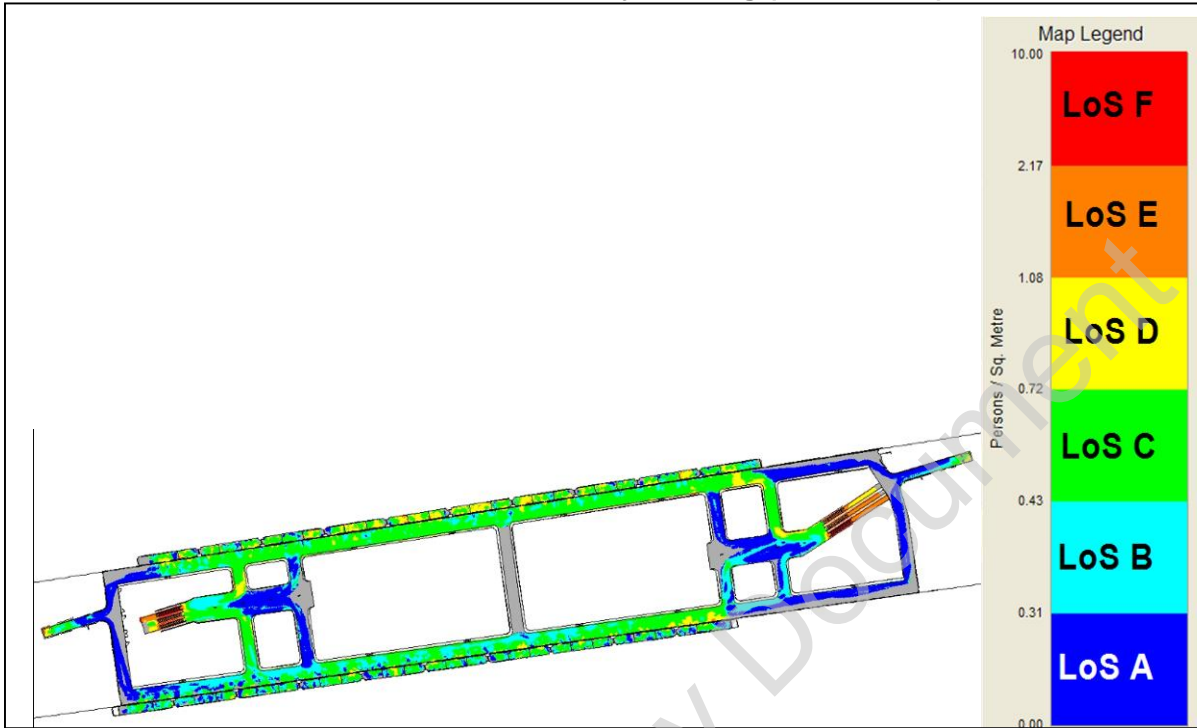
**PM Peak 2026+28% Stage E Design Platform Level  
 Cumulative Mean Density Queuing (17:45-18:00)**



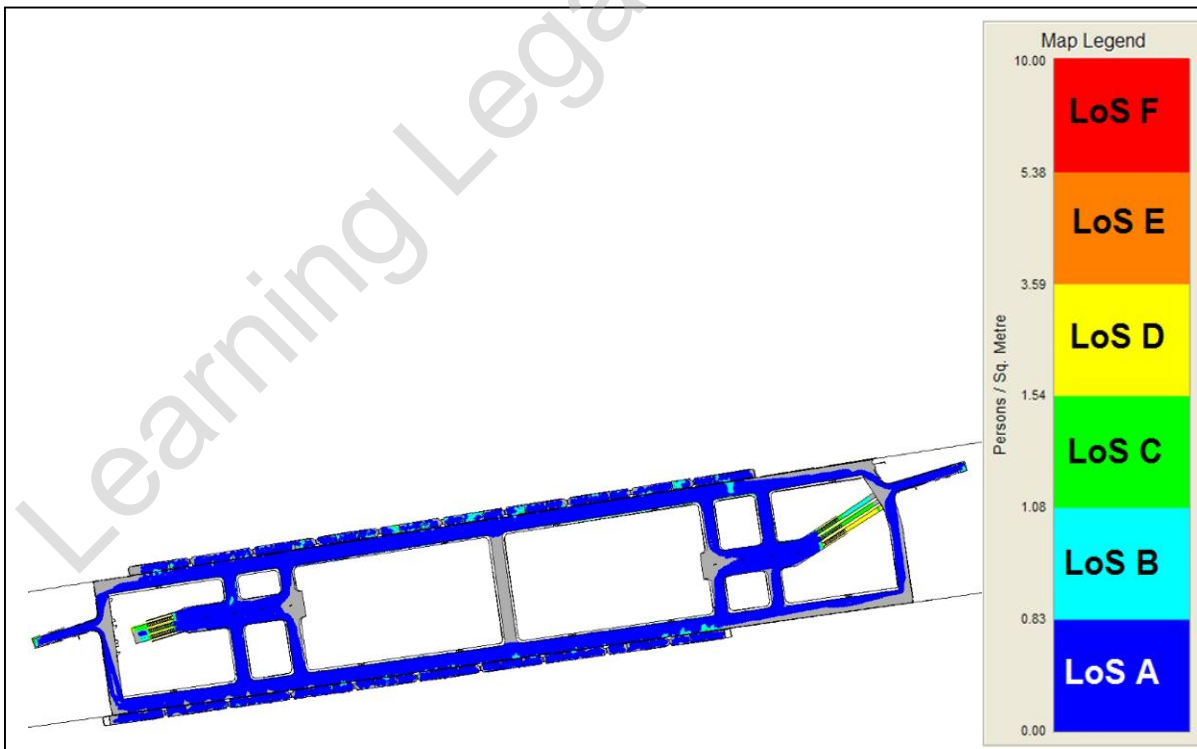
**PM Peak 2026+28% Stage E Design Platform Level  
 Cumulative High Density (17:45-18:00)**



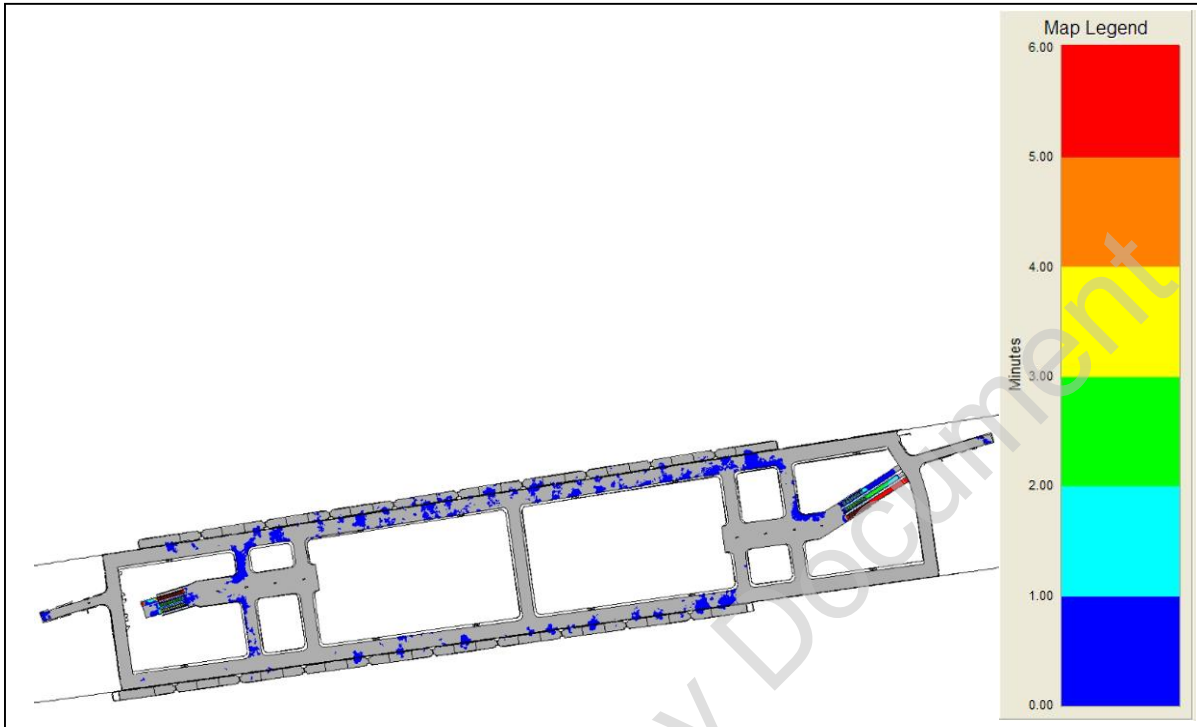
**PM Peak 2026+28% Stage E Design Platform Level  
 Cumulative Mean Density Walking (18:00-18:15)**



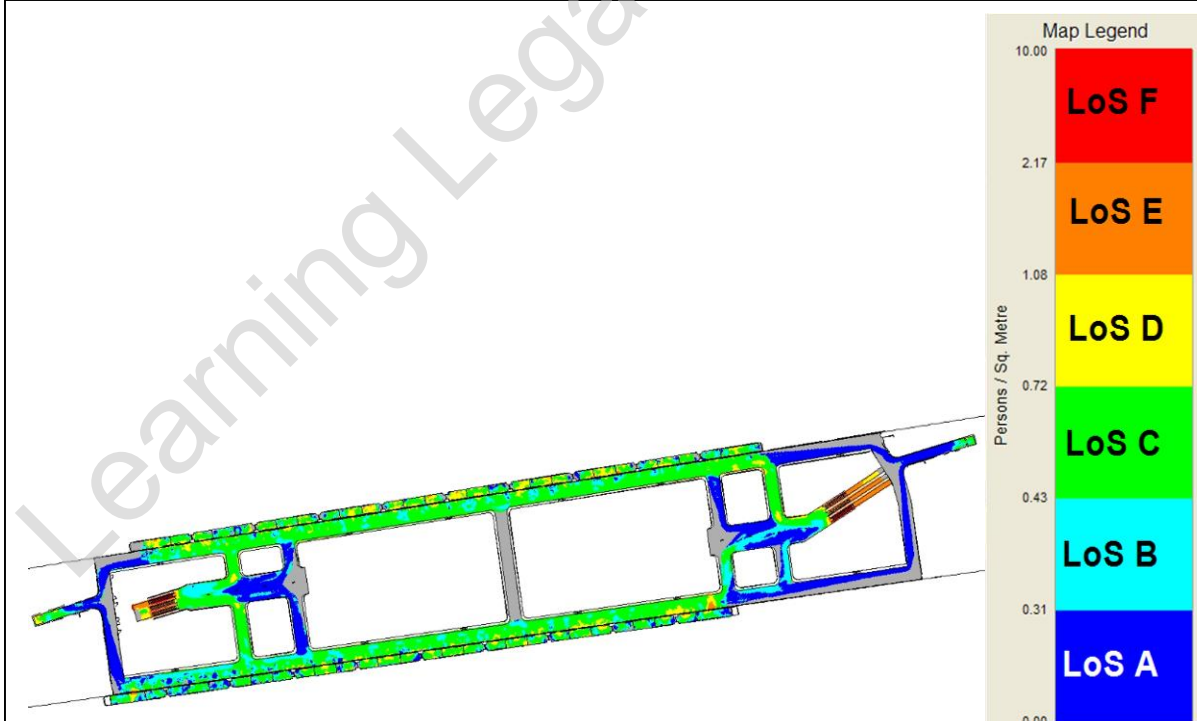
**PM Peak 2026+28% Stage E Design Platform Level  
 Cumulative Mean Density Queuing (18:00-18:15)**



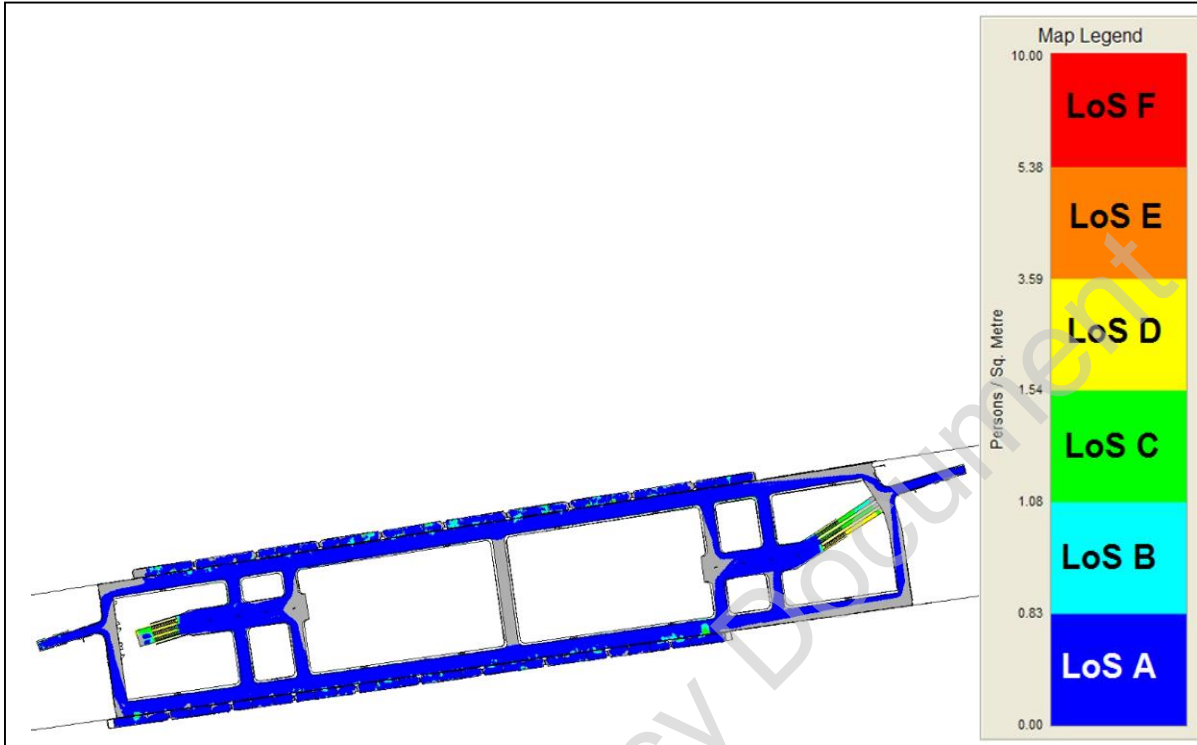
**PM Peak 2026+28% Stage E Design Platform Level  
 Cumulative High Density (18:00-18:15)**



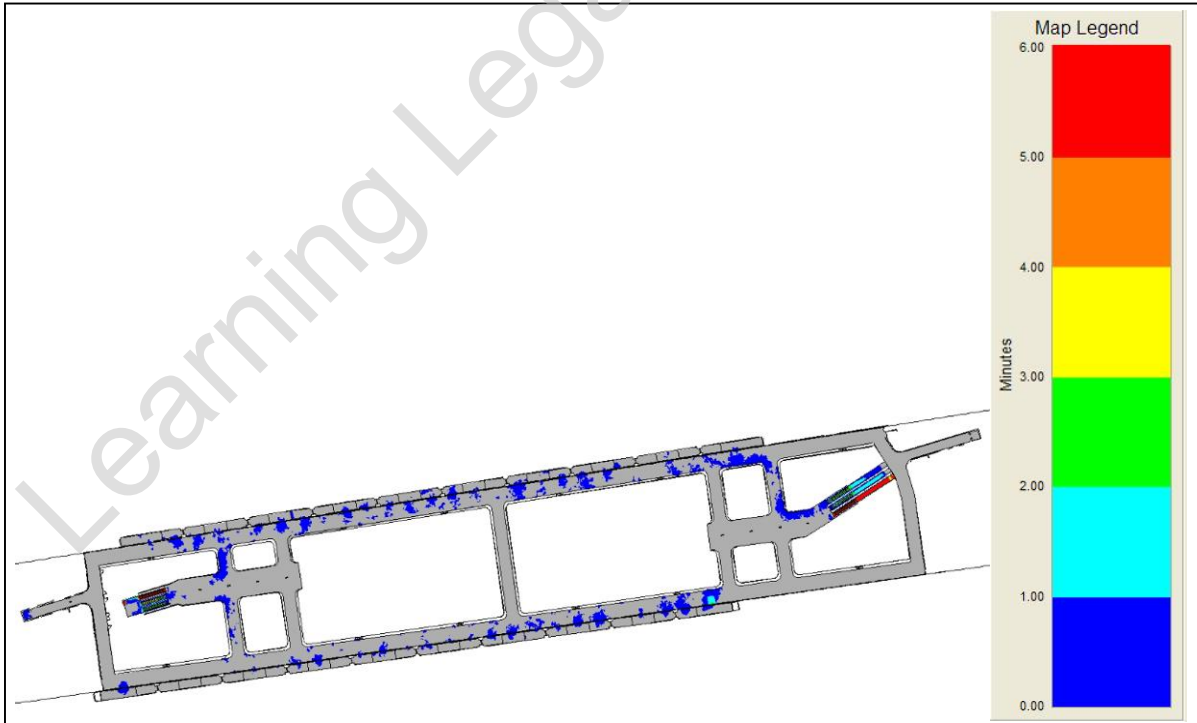
**PM Peak 2026+28% Stage E Design Platform Level  
 Cumulative Mean Density Walking (18:15-18:30)**



**PM Peak 2026+28% Stage E Design Platform Level  
 Cumulative Mean Density Queuing (18:15-18:30)**



**PM Peak 2026+28% Stage E Design Platform Level  
 Cumulative High (18:15-18:30)**



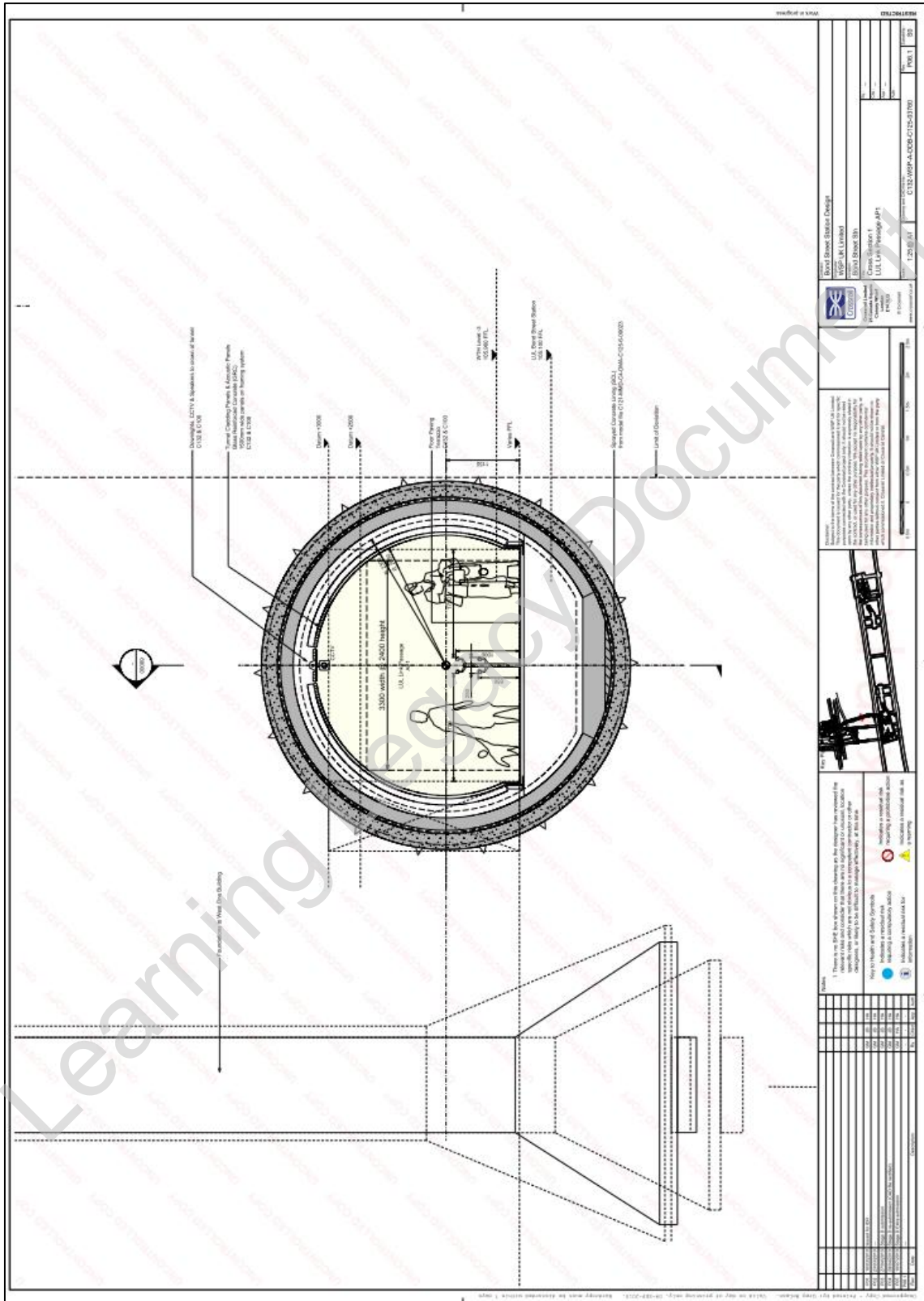


**Appendix I – Cross Section CAD Drawings**

Learning Legacy Document



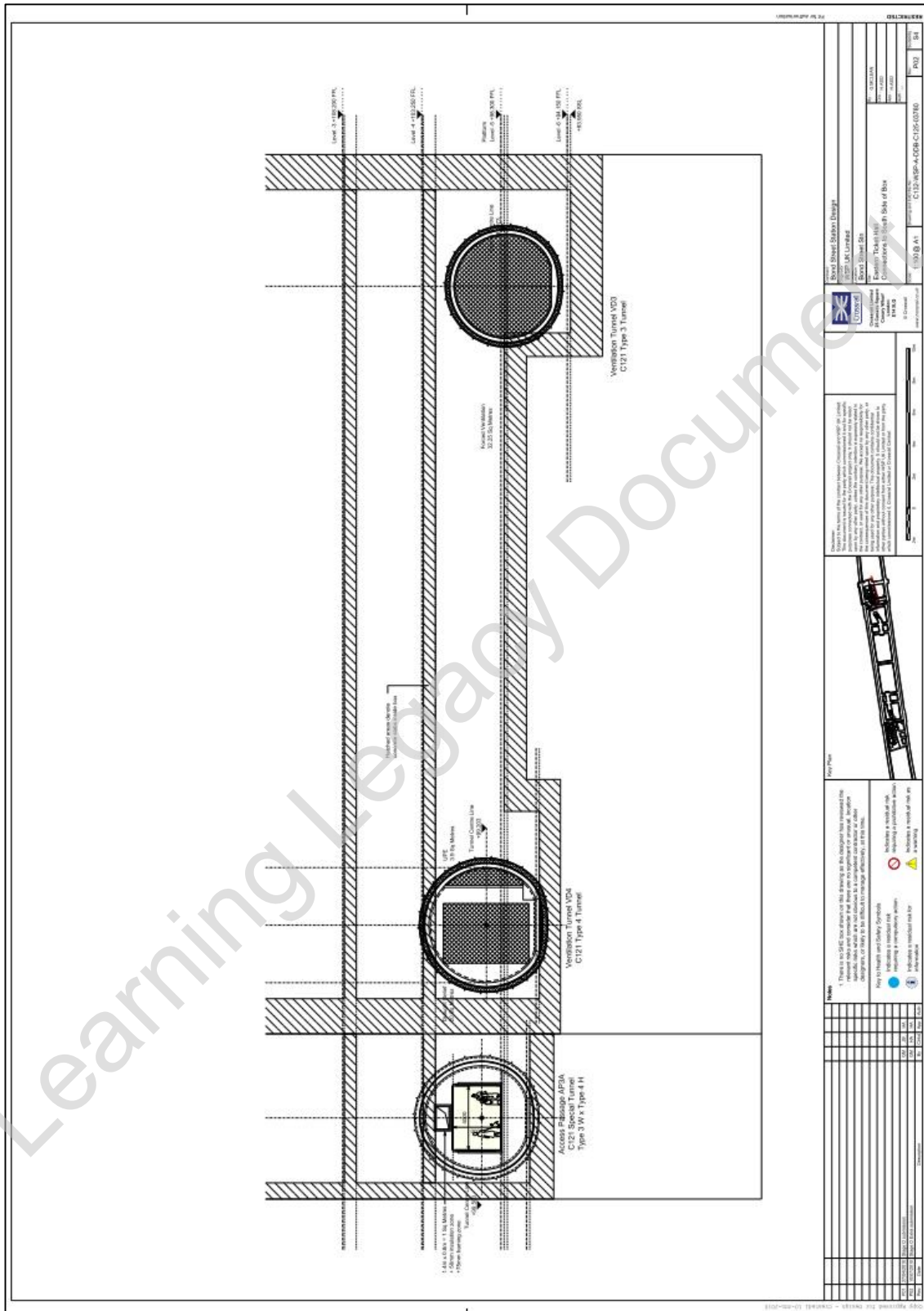
LU Passage Cross Section







Eastern Passageway to Lifts Cross Section



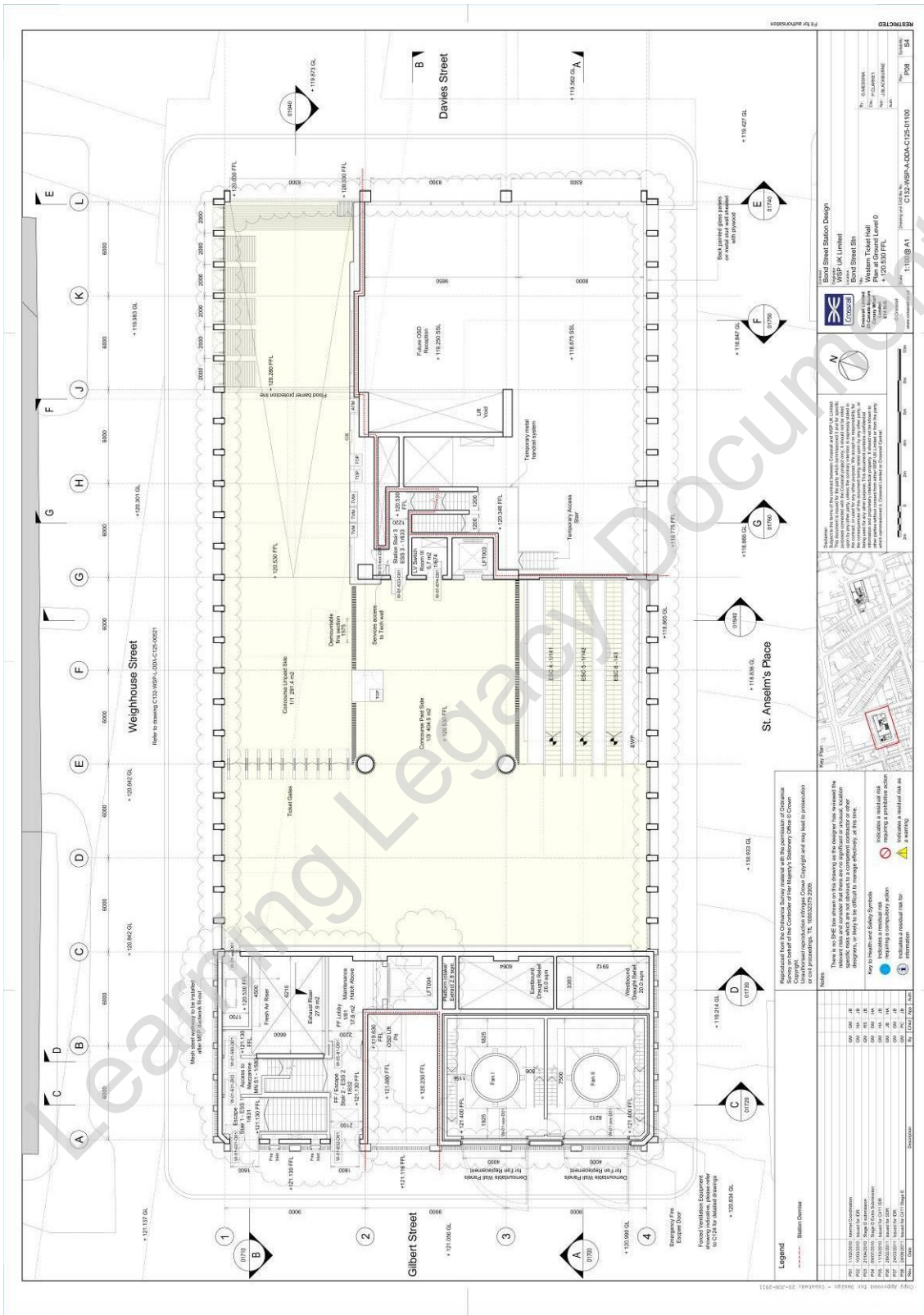




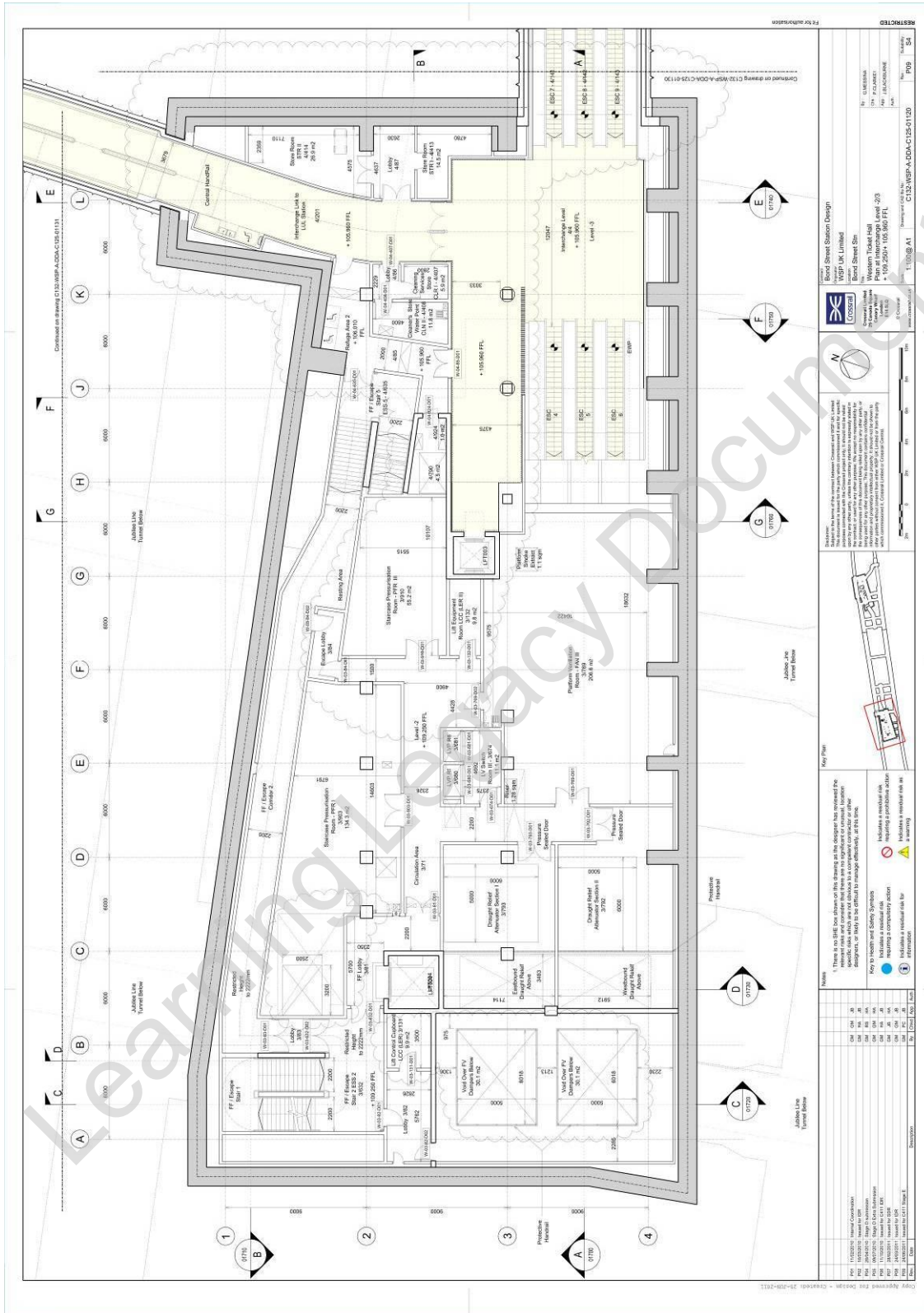
**Appendix J – Stage E Auto CAD Drawings**

Learning Legacy Document

C132-WSP-A-DDA-C125-01100.dwg

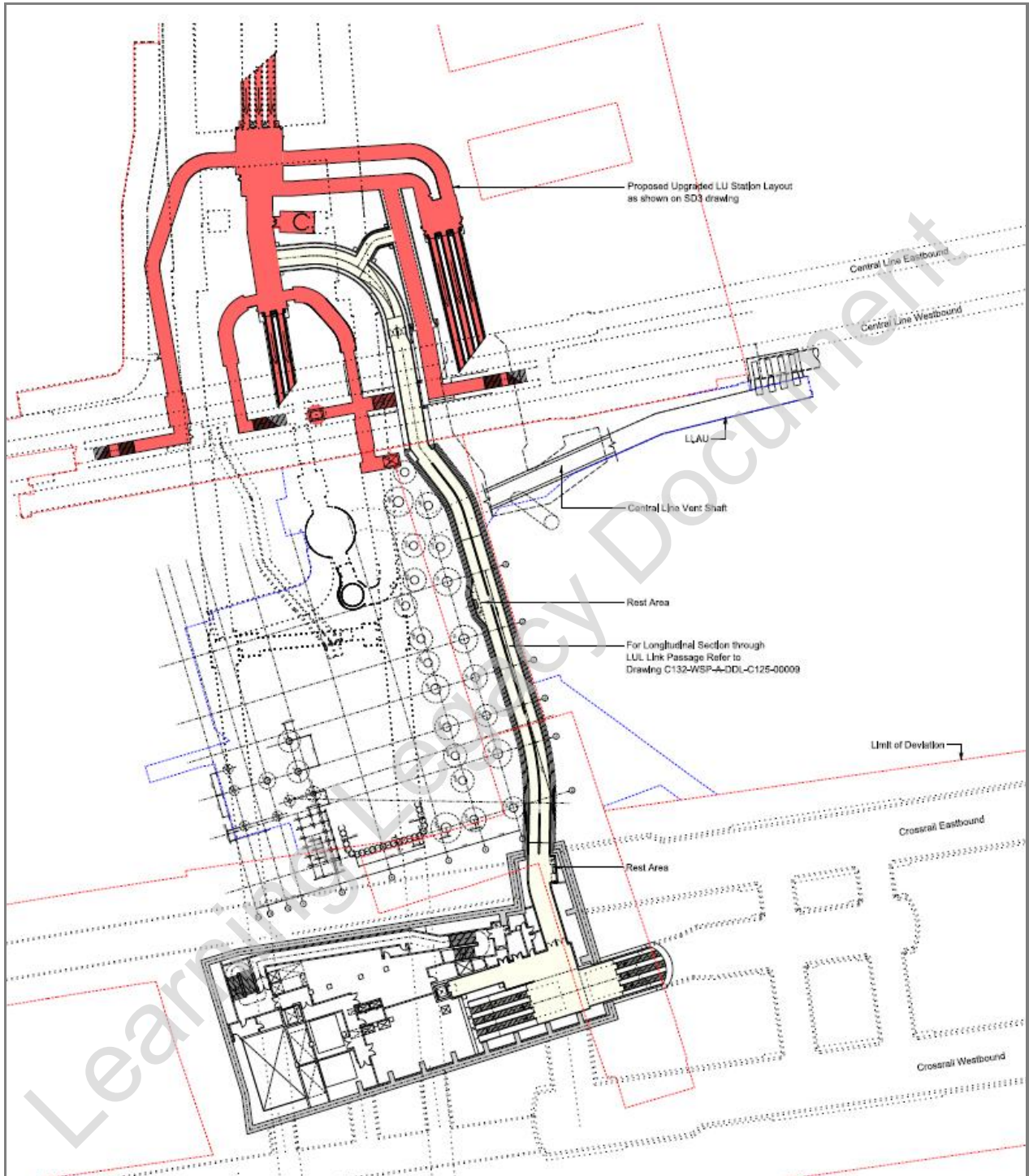


C132-WSP-A-DDA-C125-01120.dwg





C132-WSP-A-DDL-C125-00004.dwg









**Appendix K – LU Audit**

Learning Legacy Document



Ref: G22-xxx

Station Modelling Team  
London Underground  
Floor 2N,  
55 Broadway  
London  
SW1H 0BD

09 November 2010

email [REDACTED]

[www.tfl.gov.uk/tube](http://www.tfl.gov.uk/tube)

Dear [REDACTED]

**Re: Bond Street CRL Station Complex - 2026, 2026+28% AM and PM Peak Model Audit**

Please find below a summary of the issues that have been discovered following the detailed audit of the Legion modelling work conducted for the '2026 impacts assessment' work stream for Bond Street station. These issues are due to be discussed at our 'Post Audit Meeting' currently scheduled for the afternoon of Wednesday November 10<sup>th</sup> at London Underground offices.

The audit constituted interrogating the 2026 and 2026+28% AM and PM Peak models and was split roughly into three discrete stages:

- **Stage 1: Input Audit;** ensuring the assumptions detailed in the Assumption Cover Sheet for each model were being upheld
- **Stage 2: Logic Audit;** ensuring the architecture and internal model logic in the Legion Model builder were both accurate and sensible. Also making sure that Best Practice Guides/ guidelines were being taken into account
- **Stage 3: Output Audit;** involved simulating an Origin-Destination matrix and producing a rival .RES file to ensure the FDC model run results were representative

The list of issues, that was a by-product of the audit, can be seen below. These have been given provisional, pre-discussion categories of significant/insignificant/unknown. A concise list of these issues which will inform discussion (and determine whether the significant issues may constitute a model re-run) at the Post Audit Meeting can be seen on the final page.

**BDS1: The Train Arrival Profiles in the 2026 AM Peak Model are inaccurate – Alighting passenger arrivals appear to be spread instead of arriving in one pulse per train hence passengers are seen alighting continuously throughout the 3 hour period [SIGNIFICANT]**

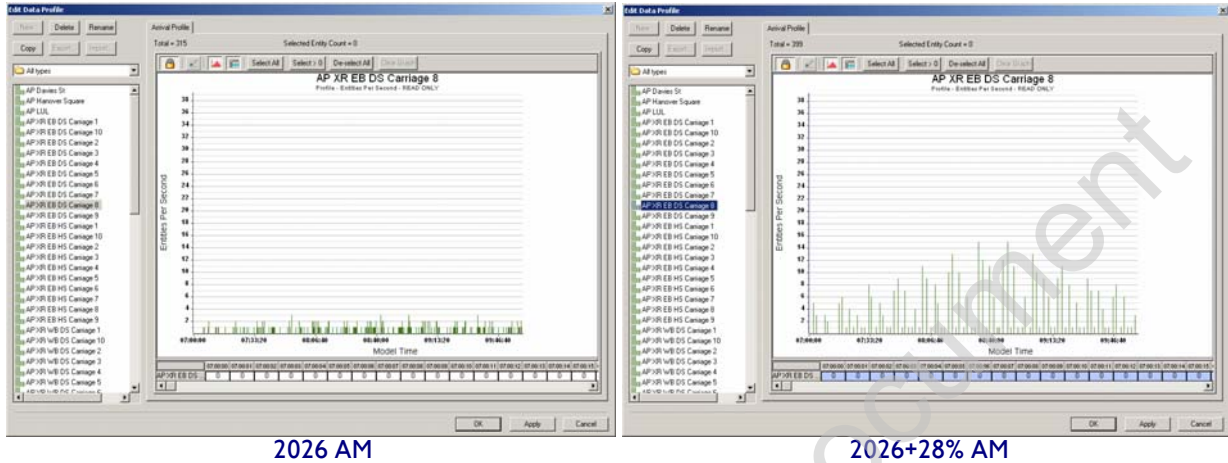
Passengers are effectively 'trickling' out of the Crossrail trains in this particular model and do not all arrive simultaneously in line with the agreed timetable detailed in the Assumption Cover Sheets. A screenshot taken from the 2026AM arrival profile compared to its 2026+28% equivalent to help highlight this issue in more detail is shown overleaf.

Registered office is as above.

Registered in England and Wales,  
Company Number 1900907

London Underground Limited is a company controlled by a local authority within the meaning of Part V Local Government and Housing Act 1989. The controlling authority is Transport for London.

This issue will lead to the platforms and surrounding infrastructure not being sufficiently ‘stress tested’ at 2026 demand levels. N.B. This does not appear to be a problem in the 2026 PM Peak and the 2026+28% models.

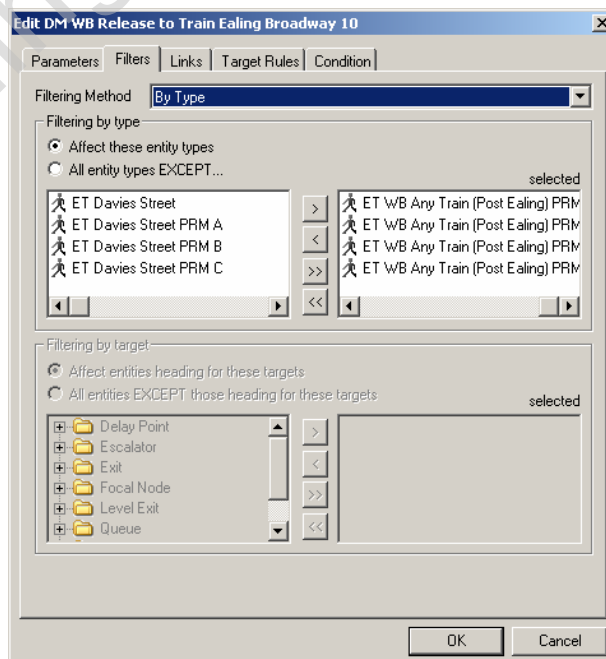


**BDS2: Ealing Broadway CRL WB service in 2026+28% models not modelled accurately [SIGNIFICANT]**

In the 2026+28% AM Peak Model, a CRL WB (Ealing Broadway) service arrives and alighters get off but there are no passengers seen boarding these services. A closer inspection of the model builder files appears to show that there has not been an event profile set up for the additional 4 Ealing Broadway services in the 30 TPH service. Therefore, the only way in which these passengers get removed from the platform are due to subsequent trains (e.g Maidenhead, Heathrow, West Drayton services).

Passengers are waiting on the platform longer than they would have to do in reality.

In the 2026+28% PM Peak Model, a CRL WB (Ealing Broadway) service arrives and passengers alight. This time there are boarding passengers suggesting an Event Profile was set up. However, the logic around which passengers’ board is incorrect. In the screenprint below, we are seeing ‘ET WB Any Train (Post Ealing)’ passengers being told to board an Ealing Broadway service when they should be told to remain on the platform for a Maidenhead, Heathrow or West Drayton service.



A recommendation would be to check all boarding logic around the CRL WB platforms in all models since the logic is fairly complex with the four/five different train services.

**BDS3: PRM Entity Speed Profiles are not in accordance with Legion Best Practice Guide [SIGNIFICANT]**

It is important PRM's are represented consistently across the entire CRL Station Modelling suite. It appears that PRM type D (Non-disabled passengers with large luggage) and PRM Type E (Adults with young children (including with pushchairs)) have been given incorrect Speed Profiles. In the model PRM's are moving at a faster rate than the guidelines recommend.

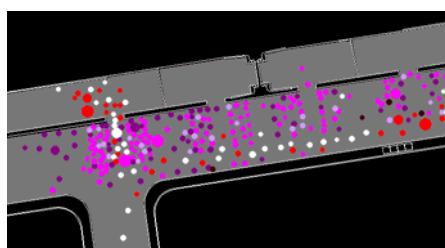
Entity Group D	Speed (m/s)	BPG %	Model %
	0.9	5%	0%
	1	8%	7%
	1.1	12%	11%
	1.2	16%	15%
	1.3	18%	21%
	1.4	16%	16%
	1.5	12%	14%
	1.6	8%	11%
	1.7	5%	5%
<b>Total</b>		<b>100%</b>	<b>100%</b>

Entity Group E	Speed (m/s)	BPG %	Model %
	1	5%	0%
	1.1	8%	5%
	1.2	12%	10%
	1.3	16%	17%
	1.4	18%	25%
	1.5	16%	16%
	1.6	12%	11%
	1.7	8%	5%
	1.8	5%	6%
	1.9	0%	5%
<b>Total</b>		<b>100%</b>	<b>100%</b>

**BDS4: In the 2026 and 2026+28% PM Peak models there is serious impediment to movement observed between 1750hrs and 1810hrs in front of carriage 10 on CRL EB platform. [SIGNIFICANT]**

At this stage in both PM Peak models there is significant difficulty for alighting passengers to depart the train from carriage 10. This is predominantly caused by boarders on the platform covering the route away from the train. More detail can be seen in the screenshot below. Is this problem because of the nature of the door configuration on the first and last carriages on CRL trains?



**BDS5: Door Widths on CRL trains inconsistent [UNKNOWN]**

Assumption # 1 on the ACS asks for the door width to be 1600mm. In some cases on CRL train's a sample of measurements taken showed that some widths are as low as 1270mm. A wider width will improve boarding and alighting times.

**BDS6: WAG delay not in line with Legion Best Practice Guide [SIGNIFICANT]**

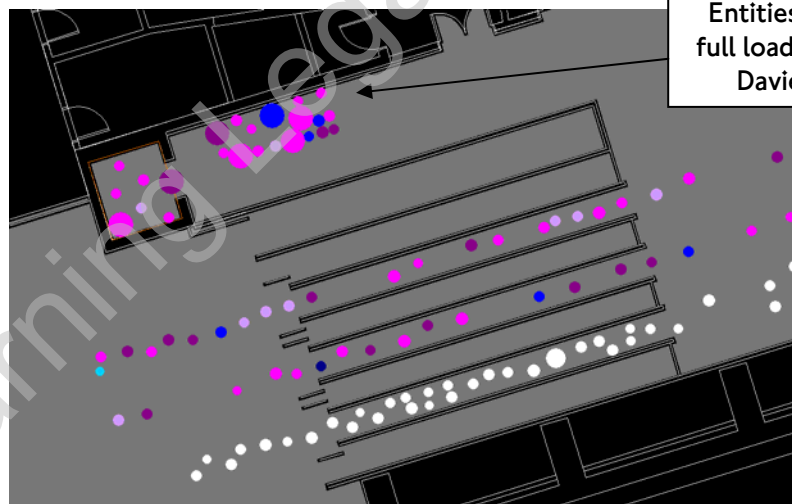
The delay on each of the uni-directional WAGs is currently too lengthy. The actual delay should mirror that of a standard UTS gate (1.8seconds). This has been deemed significant due to the Legion Best Practice Guide not being followed. However, in terms of significance on results in any associated reports, we are making any situation look worse than it actually in the area around these WAG's. The recommendation would be to rectify this in next model re-run.

Object Directory	Model	BPG	Conform with BPG
DP Ticket Gates	1.8	1.8	Yes
DP TOP Ticket Machines (FFM)	10, 15, 30	10, 15, 30	Yes
DP TVM Ticket Machines (MFM)	20, 45, 70	20, 45, 70	Yes
DP WAG's (unidirectional)	*2.4	1.8	No
Automatic gate (UTS Gate)	1.8	1.8	Yes

\* This value of 2.4s was identified in the ACS but not in conformity with 1.8s required in the BPG volume III page 01.

**BDS7: Lift Capacities/Associated Logic for the 2026 +28% PM Peak model, particularly for those passengers in the Intermediate Concourse on the Davies Street side of the station [SIGNIFICANT]**

The lift logic should be improved as entities from the intermediate level to the platform do not have the chance to use the lift as it always come with a full load from Davies Street when going to the platform level during peak periods. This should be corrected if it is a modelling inefficiency or highlighted to designers if there are genuine capacity issues. The observation worthy of note is between 1740 to 1900hours. [Entity 20373 can be highlighted].



Entities cannot use the lift as full loads are received from the Davies Street Ticket Hall

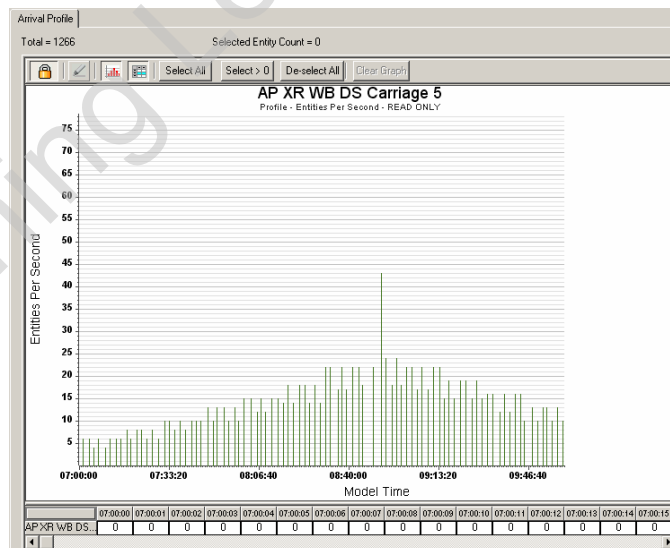
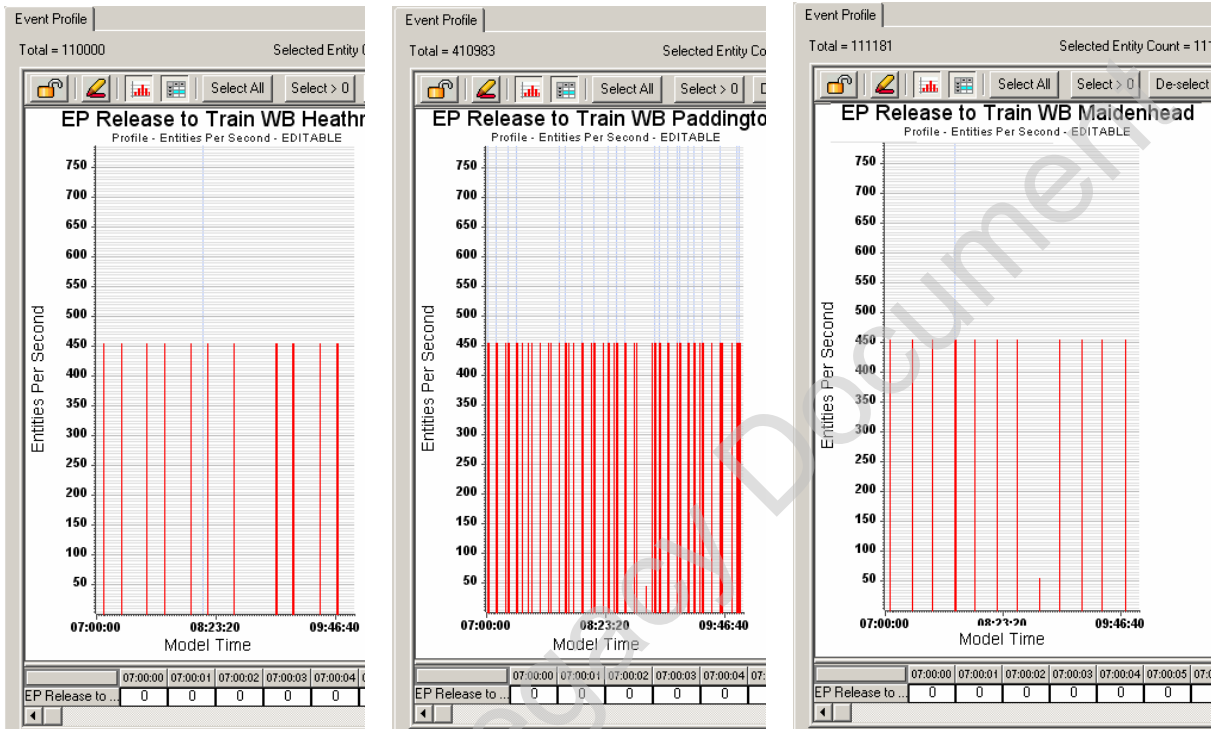
**BDS8: Boarding in places occurs sometimes 50s after train has departed [UNKNOWN]**

This was an observation spotted in the 2026 PM Peak model but could be applicable elsewhere. In this particularly model there were two 'ET EB Any Train' entities being blocked by waiting passengers travelling to a different destination. They eventually squeezed through 50 seconds later after the train scheduled departure time. Seeing passengers enter a train during a model presentation when there is no train on the platform could bring the model into question.

A recommendation would be for the boarding logic to be refined to account for such scenarios so that they are made to wait for the next train going their destination.

**BDS9: Cancelled train logic is evident but only partially captured by interrogating model [UNKNOWN]**

A greater explanation behind the theory behind the cancelled train logic on CRL platforms is required. The figures below from an Event and Arrival Profile show how some of the logic (e.g. there is a gap in the service at around 08:48) can be gathered but there is no detailed explanation.



For example:

- Why has a CRL WB Heathrow service been cancelled?
- How did the logic behind restricting the number of boarders on subsequent train come about?
- How can we be sure the most impactful cancelled train has been taken out of the scheduled timetable?



**BDS10: Platform Train Interface logic on the CRL platforms not in line with Assumption Cover Sheet #20 [UNKNOWN]**

The way in which passengers head towards the platform edge doors (PEDs) 60 seconds before the arrival of their particular service is not consistent with other models in the CRL suite. See Assumption #20 below on the ACS for what was requested to be seen in the model.

Bond Street CRL Complex - 2026 +28% Year Model - AM Peak		I	II	III	IV	V	VI	VII	VIII	IX	X	XI	XII	XIII	XIV	XV	XVI	XVII	XVIII	IXX	XX	XXI	XXII	XXIII	XXIV	XXV	XXVI
List of Input Assumptions		CRL	LU	INPUT 20: Boarding Logic																							
1. CAD (Extent of Model)				Focal nodes in the adits distribute passengers to focal nodes placed in the area in front of each carriage. Once stepped inside these carriage focal nodes passengers are evenly distributed to Waiting Zones adjacent to the PEDs for that carriage. All passengers go straight to the PEDs regardless of whether or not they are boarding the next train.																							
2. TPH	Y	Y		The distribution will be dependent on the adit location in relation to the platform. (See Input Assumption #16 for more details)																							
3. Escalator Config.				The percentages of boarding passengers having preferences for train services is calculated from Railplan 2026 run: <span style="border: 1px solid black; padding: 2px;">XR153Ru</span>																							
4. Gate/line Config.				(See Input Assumption #25 for more details)																							
5. Ticketing																											
6. PRM Routings and Rules																											
7. Non-PRM Routings																											
8. One-Way System Elements																											
9. CRL Adit Usage	Y	Y																									
10. CRL Timetable	Y	Y																									
11. CRL Cancelled Train Logic																											
12. LU Timetable																											
13. NR / Other Timetable																											
14. Constraining Alighters Logic	Y	Y																									
15. Constraining Boarders Logic	Y	Y																									
16. Boarding Profiles (CRL)	Y	Y																									
17. Boarding Profiles (LU / Other)	Y	Y																									
18. Alighting Profiles (CRL)	Y	Y																									
19. Alighting Profiles (LU / Other)	Y	Y																									
20. Boarding Logic	Y	Y																									
21. Dwell Time Logic	Y	Y																									
22. 15 Minute Profiling	Y	Y																									
23. TPH broken up into 15 minute periods	Y	Y																									
24. 15 Minute Demand to Train Services	Y	Y																									
25. B & A Percentages																											
26. Accuracy of Seams																											

In all other FDC models we have passengers, regardless of destination, immediately heading towards the Platform Edge Doors and waiting there for the duration of their stay (and not at the back of the platform) until their particular service arrives.

**BDS11: There is already a small discrepancy in demand before the model has been run - in larger models could become a problem [INSIGNIFICANT]**

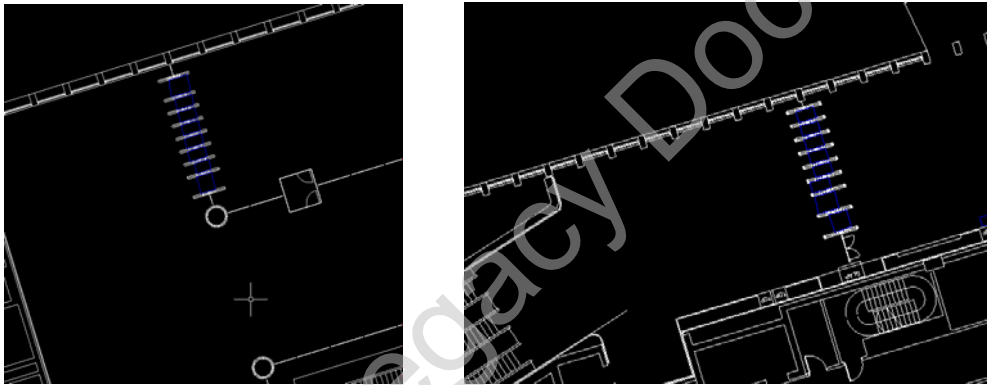
Using the 2026+28% AM Peak model the following figures were produced which shows we are already a discrepancy of 31 passengers before we even start modelling. A suggested remedy for future reference would import a 100% profile into Legion and then separate out alighting loads into carriages; this avoids passengers getting lost due to truncation errors in spreadsheet calculations.

2026 + 28% With Crossrail - AM Peak Period Demand at Bond Street										
BOSXR153RuAM	BOND ST EXISTING LUL SE	BOND ST DAVIES SE	BOND ST HANOVER SQ SE	BOND STREET CENTRAL (EB)	BOND STREET CENTRAL (WB)	BOND STREET JUBILEE (NB)	BOND STREET JUBILEE (SB)	BOND ST CROSSRAIL (EB)	BOND ST CROSSRAIL (WB)	TOTAL
BOND ST EXISTING LUL SE	0	0	0	1218	84	258	320	0	0	1856
BOND ST DAVIES ST SE	0	0	0	0	0	0	0	448	182	640
BOND ST HANOVER SQ SE	0	0	0	0	0	0	0	1080	960	2048
BOND STREET CENTRAL (EB)	1728	0	0	0	0	512	1152	840	84	4096
BOND STREET CENTRAL (WB)	4180	0	0	0	0	1024	0	0	268	5440
BOND STREET JUBILEE (NB)	7808	0	0	320	1782	0	0	0	1024	10944
BOND STREET JUBILEE (SB)	5056	0	0	6080	440	0	0	1472	1152	14208
BOND ST CROSSRAIL (EB)	0	1024	4928	192	0	128	1152	0	0	7424
BOND ST CROSSRAIL (WB)	0	6464	5852	0	1664	886	0	0	0	14876
<b>TOTAL</b>	<b>18752</b>	<b>7488</b>	<b>10880</b>	<b>7808</b>	<b>3968</b>	<b>2816</b>	<b>2624</b>	<b>3648</b>	<b>3648</b>	<b>61632</b>

	Model	CPFRv5 2026 AM Peak + 28%	
Davies Street	638	640	2
Hanover Sq	2048	2048	0
LUL	4607	4608	1
CRL EB	7407	7424	17
CRL WB	14965	14976	11
			31

**BDS12:** WAGS are not positioned on either side of the gateline in the Hanover Square Ticket Hall but they are in the Davies Street Ticket Hall – are we sure we have the optimal arrangement/configurations at these gatelines? [INSIGNIFICANT]

This was an observation from reviewing the model which shows a difference in configuration between the two ticket halls. Have the designers/modellers thought about crossflows in this area, position of WAGS for lift users when arriving at these final positions for the Wide Aisle Gates?



**BDS13:** Multitude of CAD Layers – Close to 100, Are these all needed? [INSIGNIFICANT]

Deemed insignificant since does not affect model results in any way, but when considering future manipulation and development the set of models audited may benefit from a trimming/merging exercise to reduce the number of CAD layers.

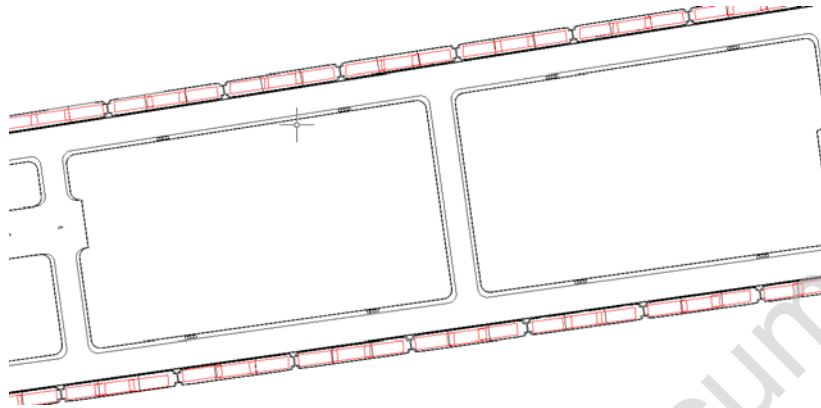






**BDS14: Excessive use of Exit Objects on the CRL Platforms**

A possible recommendation for future models would be to use just one exit object per train.



**BDS15: Name of file 'Bond St PM Sept 2010 For Report' is somewhat misleading [INSIGNIFICANT]**

A recommendation for file naming conventions would be to include 2026AM or 2026PM in the file name and avoid using the delivery date [e.g 'Sept 2010' being in the filename for the 2026 models]. Insignificant, but will help with future model development and location on local servers.

Kind Regards

[Redacted]

[Redacted]

Recipients:

[Redacted]

CC:

[Redacted]

[Redacted]

[Redacted]

[Redacted]

ISSUES LOG - Audit of the Bond Street CRL Complex - 2026 and 2026+28% AM and PM Peak Models

Post Audit Meeting - Wednesday 10th November 2010 [WSP, CRL, London Underground]

SIGNIFICANT UNKNOWN INSIGNIFICANT

ACTION

		SIGNIFICANT	UNKNOWN	INSIGNIFICANT	ACTION
BDS1	The Train Arrival Profiles in the 2026 AM Peak Model are inaccurate – Alighting passenger arrivals appear to be spread instead of arriving in one pulse per train hence passengers are seen alighting continuously throughout the 3 hour period [SIGNIFICANT]				
BDS2	Ealing Broadway CRL WB service in 2026+28% models not modelled accurately [SIGNIFICANT]				
BDS3	PRM Entity Speed Profiles are not in accordance with Legion Best Practice Guide [SIGNIFICANT]				
BDS4	In the 2026 and 2026+28% PM Peak models there is serious impediment to movement observed between 1750hrs and 1810hrs in front of carriage 10 on CRL EB platform. [SIGNIFICANT]				
BDS5	Door Widths on CRL trains are inconsistent [UNKNOWN]				
BDS6	WAG Delay not in line with Legion Best Practice Guide [SIGNIFICANT]				
BDS7	Boarding in places occurs sometimes 50s after train has departed [UNKNOWN]				
BDS8	Lift Capacities/Associated Logic for the 2026 +28% models, particularly for those passengers in the Intermediate Concourse on the Davies Street side of the station [SIGNIFICANT]				
BDS9	Cancelled train logic is evident but only partially captured by interrogating model [UNKNOWN]				
BDS10	Platform Train Interface logic on the CRL platforms not in line with Assumption Cover Sheet #20 [UNKNOWN]				
BDS11	There is already a small discrepancy in demand before the model has been run - in larger models could become a problem [INSIGNIFICANT]				
BDS12	WAGs are not on either side of the gateline in the Hanover Square Ticket Hall but they are in the Davies Street Ticket Hall – are we sure we have the optimal arrangement/configurations at these gatelines? [INSIGNIFICANT]				
BDS13	Multitude of CAD Layers – Close to 100, Are these all needed? [INSIGNIFICANT]				
BDS14	Excessive use of Exit Objects on the CRL Platforms [INSIGNIFICANT]				
BDS15	Name of model builder file 'Bond St PM Sept 2010 For Report' is somewhat misleading [INSIGNIFICANT]				

ISSUES LOG - Audit of the Bond Street CRL Complex - 2026 and 2026+28% AM and PM Peak Models Post Audit Meeting - Wednesday 10th November 2010 [WSP - CR, London Underground]			
	SIGNIFICANT	UNKNOWN	ACTION
The Train Arrival profiles in the 2026 AM peak model are inaccurate - Alighting passenger arrivals appear to be spread instead of arriving in one pulse per train hence passengers are seen alighting continuously throughout the 3 hour period [SIGNIFICANT]			Train arrival profile re-imported into model and re-run pulsed correctly. This was resolved in the model to ensure Ealing Broadway WB is now modelled accurately.
Ealing Broadway CRL WB service in 2026+28% models not modelled accurately [SIGNIFICANT]			PRM speed profiles were revised in line with Legion Best Practice Guide.
PRM Entity Speed Profiles are not in accordance with Legion Best Practice Guide [SIGNIFICANT]			The coding in this area was resolved and the changes made to the model explained to LU at a meeting on 16th November 2010.
In the 2026 and 2026+28% PM peak models there is a serious impediment to movement observed between 1750hrs and 1810hrs in front of carriage 10 on CRL EB platform			All door widths were checked and are no consistent.
Door widths on CRL trains are inconsistent [UNKNOWN]			This change was made in all models.
WAG Delay not in line with Legion Best Practice Guide			This was resolved by improving the model going to ensure that passengers did not get blocked whilst boarding/alighting.
Boarding in places occurs sometimes 50s after the train has departed [UNKNOWN]			Following communication with the C132 lift expert the modelled travel time of the lift was revised to more accurately reflect the actual lift travel time. This was explained to LU on 16th November and subsequently in July 2011.
LIR Capacities / Associated Logic for the 2026+28% models, particularly for these passengers in the intermediate concourse on the Davis Street side of the station [SIGNIFICANT]			This was provided to C132 by CR.
Cancelled train logic is evident but only partially captured by interrogating model [UNKNOWN]			At the meeting on 10th November this issue was discussed and LU agreed that what had been completed was ok and no changes needed to be made.
Platform Train Interface logic on the CRL platforms not in line with Assumption Cover Sheet #20 [UNKNOWN]			None
There is already a small discrepancy in demand before the model has been run - in larger models could become a problem [INSIGNIFICANT]			The drawings for Hanover Square ticket gateline have subsequently changed and now the WAFs are on either side of the gateline.
WAGs are not on either side of the gateling in the Hanover Square Ticket Hal but they are in the Davies Street Ticket Hal - are we sure we have the optimal arrangement / configurations at these gate lines? [INSIGNIFICANT]			Presentation and Simulation CAD Layers in Block Capitals to highlight these layers
Multitude of CAD layers - Close to 100. Are these all needed? [INSIGNIFICANT]			None
Excessive use of Exit Objects on the CRL platforms [INSIGNIFICANT]			C132 have renamed the model files as below: Bond St PM 2026_Issued August 2011.lgn
Name of model builder file 'Bond St PM Sept 2010 Report' is somewhat misleading [INSIGNIFICANT]			



**Appendix L – Scheme History**

Learning Legacy Document

# Précis of Bond Street Pedestrian Modelling

## Appendix L

1. Legion modelling for BOS was compliant with the CPFR at Stage C/SD3 design. A due diligence check was undertaken on the model provided by Crossrail, prior to design work commencing. This established that the model provided by Crossrail was compliant with the CPFR. This compliance was maintained throughout Stage D and the report produced at the end of this stage did not highlight any problems. C132 then proceeded to produce a “Stage D Extra” design.
2. At the same time as work on Stage D Extra started EAI019 was issued by Crossrail. Prior to this instruction no compliance issues were known about or foreseen. For this reason the “Scheme History” prior to EAI019 has not been expanded upon.
3. A period of 17 months has elapsed since the issue of the EAI019 and the production of this final report. Much documentation has been produced as the modelling has progressed. This documentation is too extensive to reproduce in this report; however it is summarised together with the key dates on the following pages.
4. Key events and turning points in the modelling are however summarised as follows.

### Western Ticket Hall

5. The inclusion of a fourth escalator at the WTH between the intermediate and concourse levels was recommended by C132 on 14 April 2011. Prior to this an EWN had been issued on 22<sup>nd</sup> October 2010, which stated that “An additional escalator maybe required between the platform and intermediate level”
6. Crossrail also suggested that there was a “Vertical Capacity” issue at the WTH
7. CRL/LU and C132 held a series of meetings from December 2010 to July 2011 at which various ways of overcoming the non-compliant flow levels at the WTH were discussed, and then modelled by C132. None of the ideas solved the compliance issue and to C132 it was apparent that the WTH could not cope with the additional passenger flows introduced by EAI019
8. On 21 April 2011 WSP were issued with a revised 3 hour PM peak hour matrix and instructed to introduce it to the model. This matrix removed 4000 passengers from the WTH and re-assigned them to the ETH.
9. The new matrices combined with recoding of the escalators (2up, 1down) at the WTH all but solved the problem.
10. Modelling undertaken with the revised PM Peak matrix was compliant up until 2026+14% at platform level and 2026+21% at Intermediate level (The CPFR require 2026+28% to be achieved where possible). To overcome the non-compliant situation between at the Intermediate level+21% and +28% it was suggested that the fire stairs at the WTH be used as a means to reach the platforms. Calculations were then undertaken and showed that when the

# Précis of Bond Street Pedestrian Modelling

## Appendix L

incoming passengers utilising the LU Link tunnel were assigned to the stairs, compliance was achieved. To overcome the problem at platform level it was suggested that announcements are made at platform level to encourage pedestrians to spread out along the platform.

### Eastern Ticket Hall

11. Use of the fire stairs from +21% represents passive mitigation to be introduced in 2068
12. At the ETH a non-compliance at platform level was overcome by reconfiguring the escalators to 2up, 1 down. Removing passengers from the platform in a faster manner moved the problem up to the ETH gate line. The stations box geometry did not lend itself to the addition of further UTS gates though. To resolve the gate line congestion non-PRMs were allocated to the two WAGS. This resolved the problem.
13. As stated in the final report there were no non-compliances at the ETH.
14. Following the introduction of the PM peak matrices which moved 4,000 passengers from the WTH to the ETH; C132 requested an updated AM peak matrix with a similar re-assignment. C132 were however informed that, *“the current AM matrix is considered suitable for this work by Crossrail and LUL.”*
15. Inclusion of the matrices provided by Crossrail has been on an “execute only” basis by C132, i.e. The matrices themselves form Appendix B to the CPFR and therefore must be complied. C132 has not therefore undertaken any checking or review of the matrices, this being beyond the scope of the C132 NEC contract. Any checking review of the matrices would require a knowledge of London wide and south eastern multimodal assignments; a skill C132 does not have.
16. This report therefore constitutes the summary of the best available solution to the BOS modelling without the introduction of a fourth escalator.

# Précis of Bond Street Pedestrian Modelling

## Appendix L

- **15th April 2010** – EWN 106 issued, following advance notice from CRL that revised pedestrian matrices would be issued at some future date.
- **22nd April 2010** - Stage D Pedestrian Modelling Report issued [C132-WSP-T3-RGN-C125-00002 Rev 1.0] – **COMPLIANT**
- **27th April 2010** – EAI GEN 019 issued. This required C132 to produce an “Impact Assessment”, based on the pedestrian matrices that were attached to the instruction. It also changed the assessment criteria to 2026+28% and gave notice that cover sheets and assumptions would be issued on a station specific basis. Note, this instruction, whilst dated the 27<sup>th</sup> April, was not received until 6<sup>th</sup> May 2011.
- **22nd April 2010** - Stage D Pedestrian Modelling Report Issued [C132-WSP-T3-RGN-C125-00002 Rev 1.0] – **COMPLIANT**
- **25<sup>th</sup> May April 2010** - Stage D Pedestrian Modelling Report Issued, responding to CRL comment sheets. [C132-WSP-T3-RGN-C125-00002 Rev 2.0] – **COMPLIANT**
- **8<sup>th</sup> August 2010** – EAI 024 issued. This required C132 to implement the pedestrian matrices that were attached to the instruction EAI GEN 019. Old and new demand matrices were attached to the instruction, as were revised CPFR and peaking factors.
- **13th August 2010** - EWN 140 issued (Documentum Reference C132-WSP-V-NEW-C125-000140) highlighting that C132 are to implement EAI GEN 019 matrices (as per instruction EAI 024). The EWN pointed out that C132 were being instructed to implement the matrices, prior to impact of these being fully understood.
- **8th October 2010** – Impact Assessment Report of Revised Demand for Bond Street issued, as a response to EAI 019 [C132-WSP-T3-RGN-C125-00005 Rev 1.0] – **NON-COMPLIANT**
- **20th October 2010** – EWN 162 issued (Documentum Reference C132-WSP-V-NEW-C125-000162) highlighting the non-compliant issues highlighted in the report issued 8<sup>th</sup> October 2010. EWN concludes that additional Gates will be needed at both the ETH and WTH. The EWN draws attention to the fact that an additional escalator may be needed at the WTH between platform and intermediate levels.
- **10th November 2010 13:34** - Received comments from LU Audit of Bond Street Legion Models
- **10th November 2010 15:00** – Meeting for feedback from LU on EAI GEN 019 (CPFR 5.0) Bond Street Legion Models
- **24th November 2010** – Revised Pedestrian Modelling report for EAI GEN 019 issued following LU Audit [C132-WSP-T3-RGN-C125-00005 Rev 2.0] - **NON-COMPLIANT**
- **7<sup>th</sup> December 2010 14:51** - E-mail to C132 Project Engineer (GG) confirming “*Modelling has been undertaken correctly.*”

# Précis of Bond Street Pedestrian Modelling

## Appendix L

- **21st December 2010** – Meeting with Crossrail ( [REDACTED] ) C132 were asked to reconfigure the Davies Street to Platform escalators.
- **24th January 2011** – Addendum Report of Legion model runs with revised escalator configurations issued [C132-WSP-T3-RGN-C125-50001 Rev 1.0] - **NON-COMPLIANT**
- **7th February 2011** – Comments received from Crossrail on Addendum Report
- **11th February 2011** – Meeting with Crossrail ( [REDACTED] ) list of runs suggested to improve non-compliance issues.

	1 Escalator Up 2 DOWN	2 Escalators Up 1 DOWN
Revising position of EB train (further westwards) and boarding percentages (CR to provide)	✓	✗
Adit Split Change (from 85%/15% to 60%/40%)	✓	✓
One Way System for Adits	✓	✓
Constraining Davies Street flow - reduction in inbound ticket gates	✗	✓
Removing 10% of demand from Davies Street to Hanover Square	✗	✓

- **30th March 2011** – Second Addendum document issued to Crossrail. Western Ticket Hall Legion Modelling Report. [C132-WSP-T3-RGN-C125-50003] - **NON-COMPLIANT**
- **Between 30<sup>th</sup> March and 14<sup>th</sup> April.** - C132 run a range of scenarios within the Bond Street pedestrian model to try to resolve the non-compliant issues highlighted in their Impact Assessment Report of the Revised Demand (issued 23<sup>rd</sup> November 2010). The non-compliant issues that remain are the pedestrian density levels on the platform and Intermediate/ Platform area by the WTH escalators (depending on their configuration) in the PM peak. These are required to be resolved so that C132 comply with CPFR 5.0.
- **14<sup>th</sup> April 2011** – Meeting with Crossrail and LU ( [REDACTED] ), [REDACTED] further runs suggested.
- **18<sup>th</sup> April 2011 09:47** – [REDACTED] issues the Actions from the meeting on 14<sup>th</sup> April to all present.
- **18<sup>th</sup> April 2011 10:02** – [REDACTED] sends through revised Eastbound platform boarding profile
- **19<sup>th</sup> April 2011** - RFI 237 Issued, requesting information to explain the disparity between the Railplan data and flows in the LU link passage. CRL response confirms that different data is being used by the LU upgrade project and C132 BOS Design.
- **20<sup>th</sup> April 2011 17:01** – [REDACTED] instructs C132 to run the PM peak model with the following:
  - PM Peak revised matrix
  - The boarding profiles have been sent by [REDACTED] (18<sup>th</sup> April)



# Précis of Bond Street Pedestrian Modelling

## Appendix L

- Number of gates at Hanover Square; will need to be increased from 6 to 8 - this should be the starting point [8 UTS + 2 WAGS]. Can you also remove all rules of sending Non-PRM to WAGS.
- Number of gates at Davies Street; 6 may be sufficient now - this should be the starting point [6 UTS + 2 WAGS]. Can you also remove all rules of sending Non-PRM to WAGS.
- Model runs agreed at the meeting on 14<sup>th</sup> April 2011
- **21<sup>st</sup> April 2011** 09:42 – [REDACTED] issues revised PM peak 2026 matrices to C132.
- **19<sup>th</sup> May 2011** - RFI 255 Issued, requesting a revised matrix for the AM 3 hour peak period, to reflect that the fact that 4000 passengers have been reassigned from the WTH in the PM peak, but not the AM peak period. CRL response stated that the AM Matrix is considered suitable and new matrix will not be issued.
- **16 June 2011** - C132 meet CRL/LU to discuss Legion Modelling results arising from the meeting of 14<sup>th</sup> April 2011. Compliant solution for 2026 PM peak found using revised matrices. C132 to now issue model to LU for further checks and focus on breakpoint modelling for 2026+28%.
- **5<sup>th</sup> July 2011** - C132 present results to LU/CRL which is finally accepted as the best possible achievable result that C132 will get. **COMPLIANT at 2026, but NON COMPLIANT AT 2026 + 28%**. Presentation made on 5<sup>th</sup> July clarifies the different scenarios. Use of fire stairs at WTH for LU link flows to platform proposed by CRL.
- **18th July 2011** – EAI 086 issued. This formalised the issue of the revised PM peak demand matrices first issued to C132 on 21st April 2011.
- **26th July 2011 – Report issued** “Legion Modelling Report, WTH, - Stage E – Final Report, C132-WSP-RGN-C125-50007 Rev 1.0” This only covered the WTH due the forthcoming C411, WTH Gate 3. This report to be expanded to cover the whole station.
- **27<sup>th</sup> July 2011** - C132 present results to LU/CRL which is finally accepted as the best possible achievable result that C132 will get. **COMPLIANT at 2026, but NON COMPLIANT AT 2026 + 28%**. Presentation made on 5<sup>th</sup> July clarifies the different scenarios.
- **4<sup>th</sup> August 2011** - C132 hold meeting with [REDACTED] and [REDACTED] to discuss the train stopping position. It is concluded that the “standard platform design” no longer applies and that CRL can cater for any of the stopping positions proposed at the meeting. It is concluded that the stopping position inherent in the model will be retained. Meeting notes [C132-WSP-N1-MRC-C125-50300], issued on 18<sup>th</sup> August 2011 document this.



**Appendix M – Breakpoint Modelling**

Learning Legacy Document



# C132 Bond St Station

## PM Peak 2026 Breakpoint Modelling

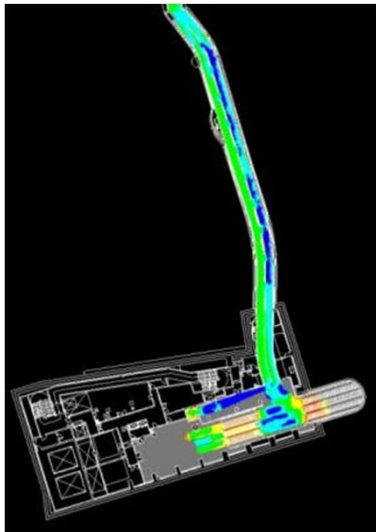
20<sup>th</sup> July 2011

Learning Legacy Document

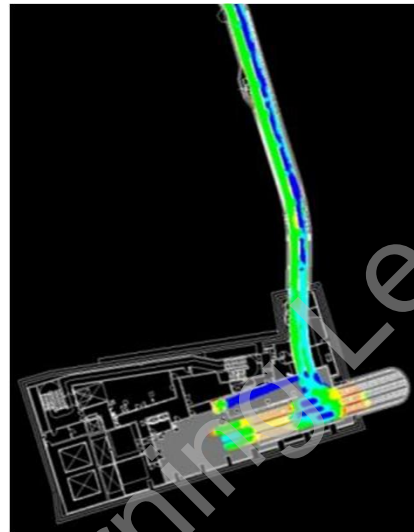


## PM Peak 2026 +7% - Intermediate Level (walking)

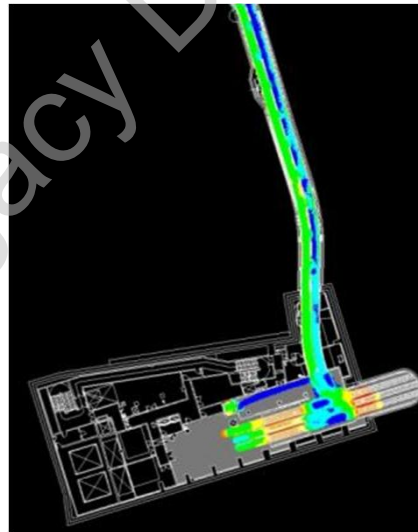
17:30 - 17:45



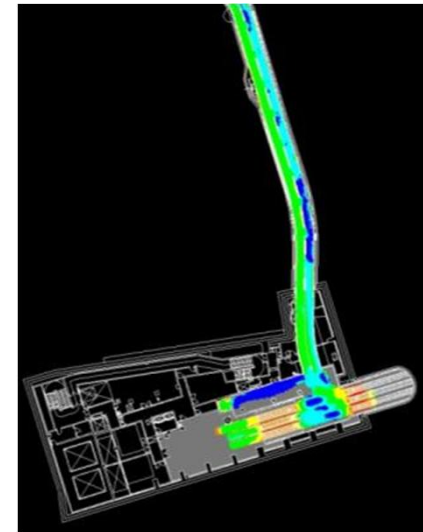
17:45 - 18:00



18:00 - 18:15



18:15 - 18:30

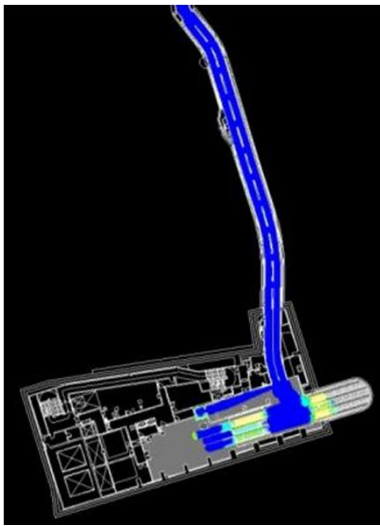


Learning Legacy Document

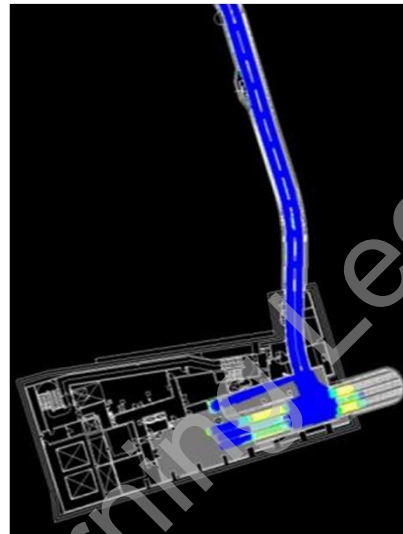


## PM Peak 2026 +7% - Intermediate Level (queuing)

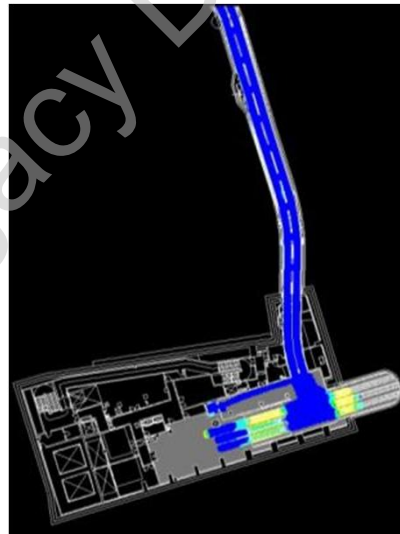
17:30 - 17:45



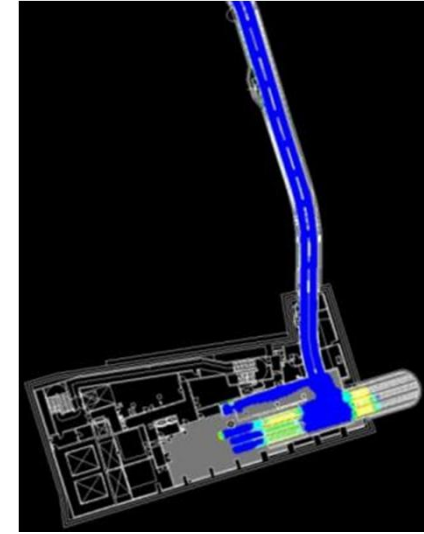
17:45 - 18:00



18:00 - 18:15



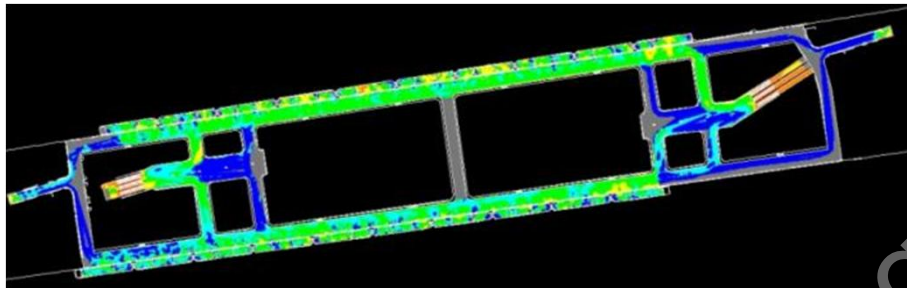
18:15 - 18:30



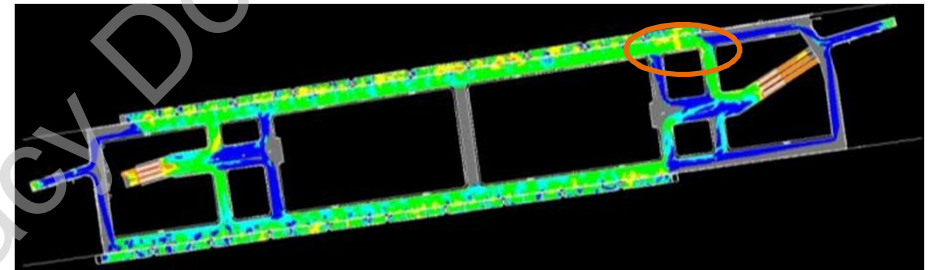
Learning Legacy Document

# PM Peak 2026 +7% - Platform Level (walking)

17:30 -17:45

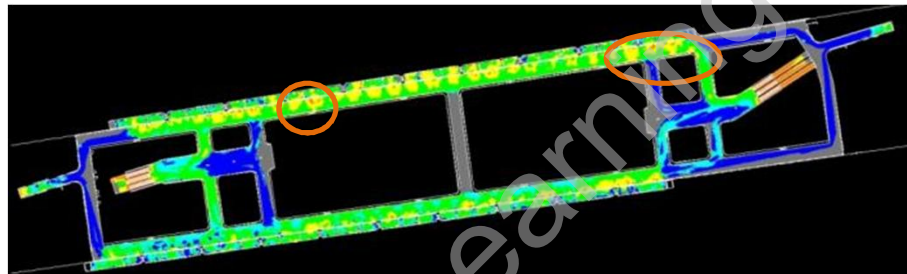


18:00 -18:15

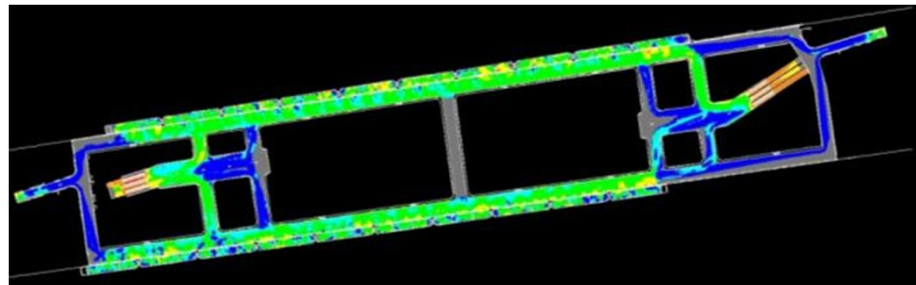


Area= 3sq/m (0.3% of platform area)

17:45 -18:00



18:15 - 18:30

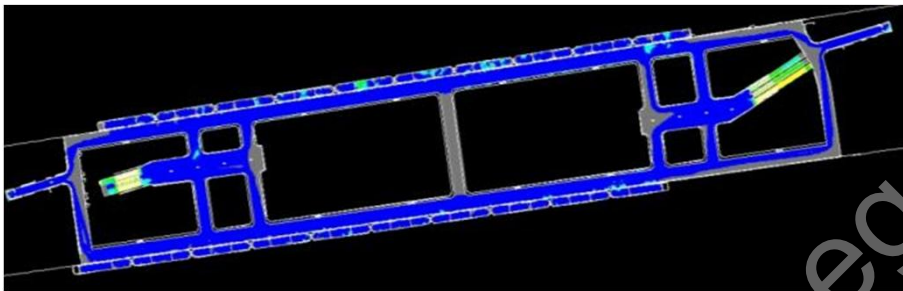


Area= 18sq/m (2% of platform area)

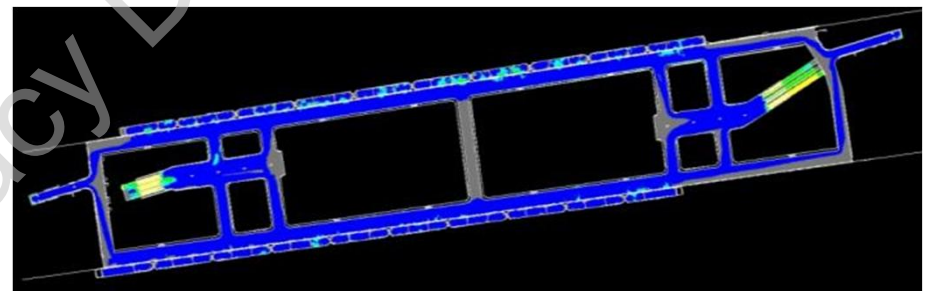


## PM Peak 2026 +7% - Platform Level (queuing)

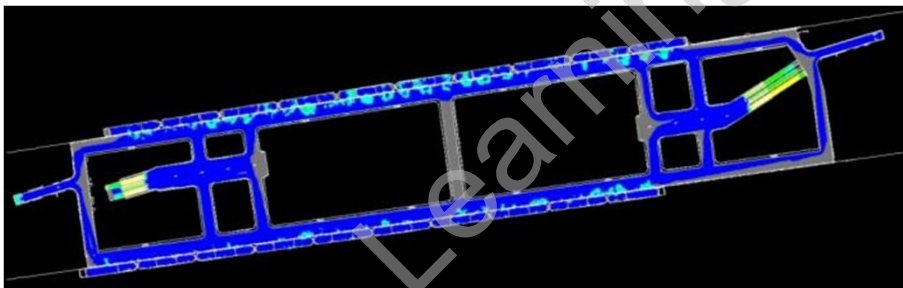
17:30 -17:45



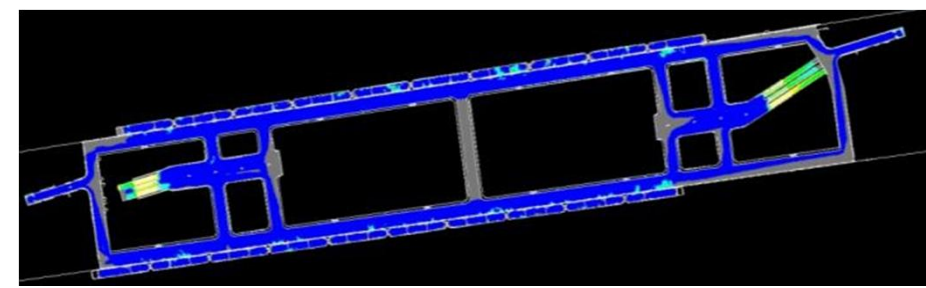
18:00 -18:15



17:45 -18:00



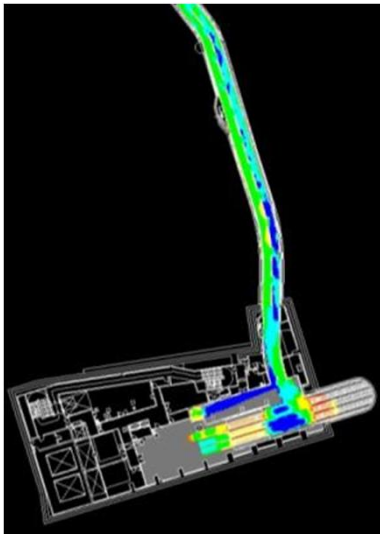
18:15 -18:30



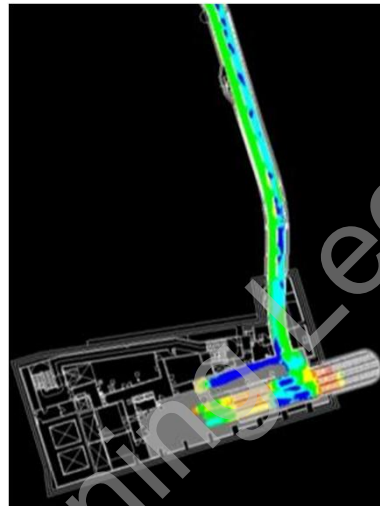


## PM Peak 2026 +14% - Intermediate Level (walking)

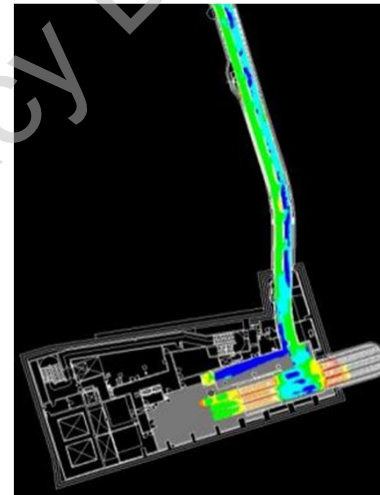
17:30 -17:45



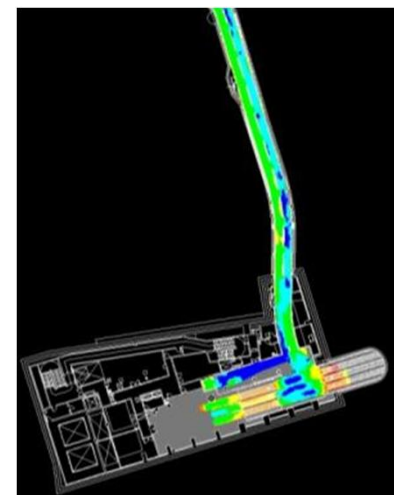
17:45 -18:00



18:00 -18:15



18:15 -18:30



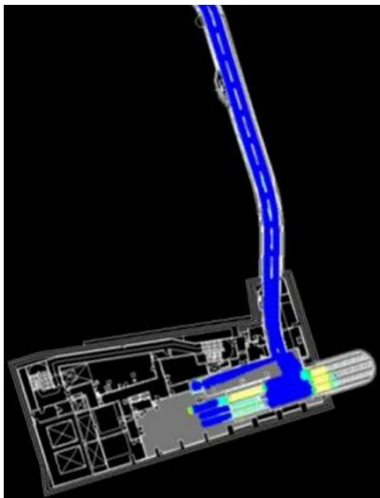
Learning Legacy Document



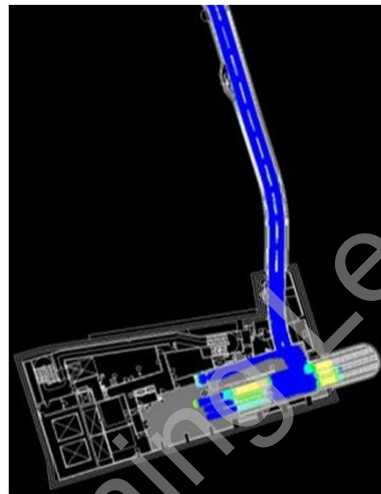


## PM Peak 2026 +14% - Intermediate Level (queuing)

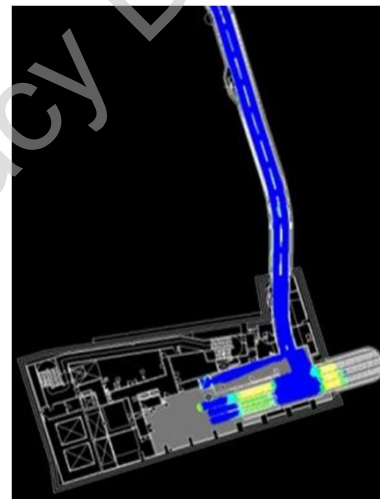
17:30 -17:45



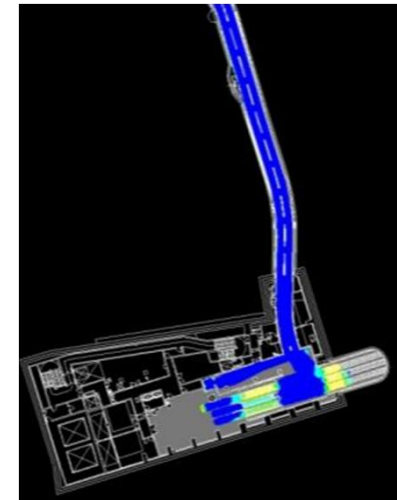
17:45 -18:00



18:00 -18:15



18:15 -18:30

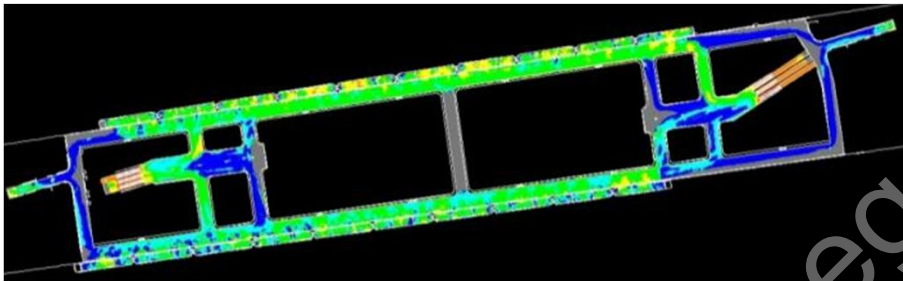


Learning Legacy Document

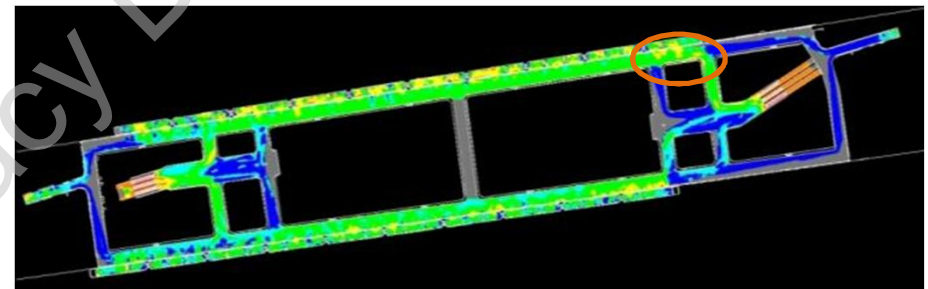


## PM Peak 2026 +14% - Platform Level (walking)

17:30 -17:45

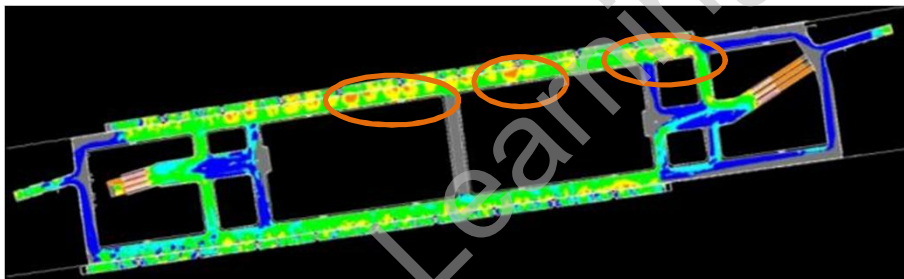


18:00 -18:15



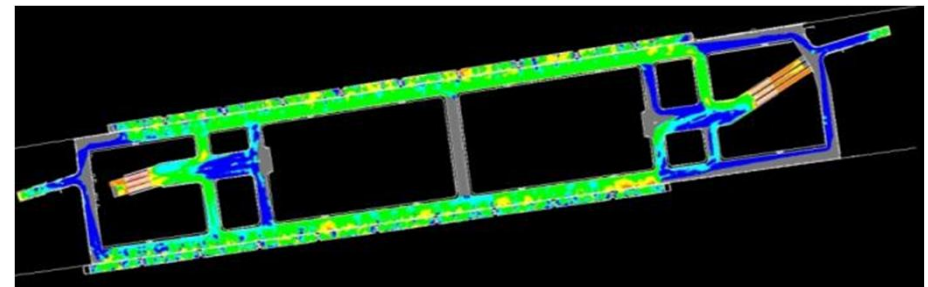
Area= 8sq/m (1% of platform area)

17:45 -18:00



Area= 58sq/m (6% of platform area)

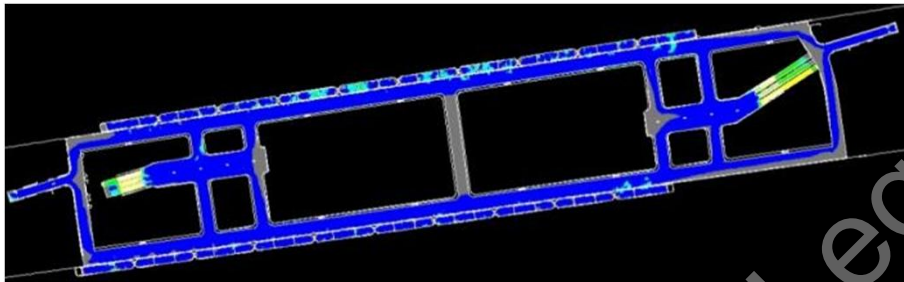
18:15 -18:30



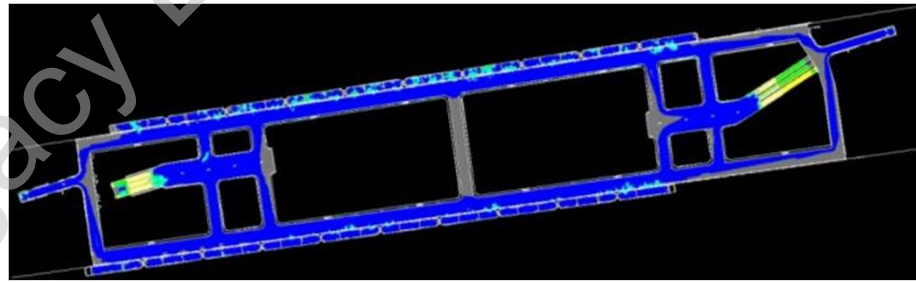


## PM Peak 2026 +14% - Platform Level (queuing)

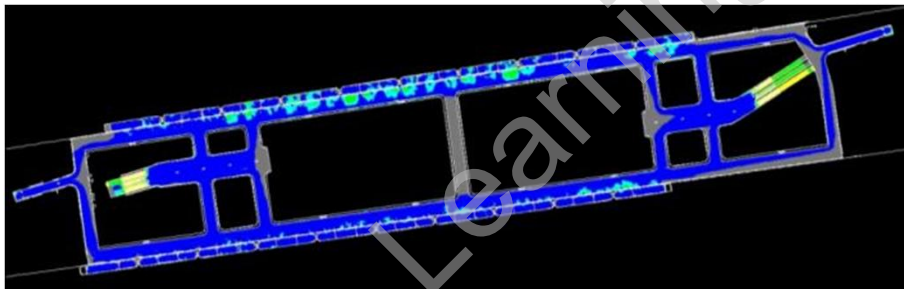
17:30 -17:45



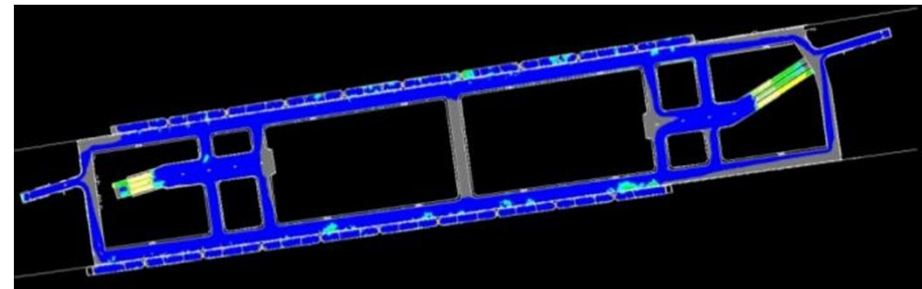
18:00 -18:15



17:45 -18:00



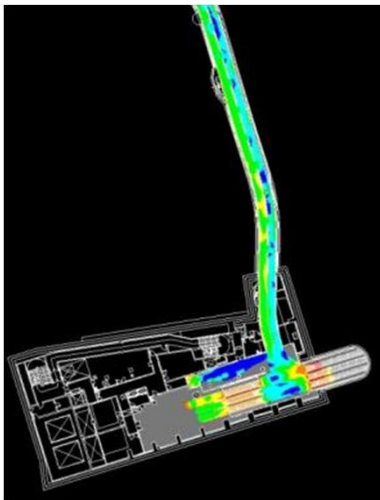
18:15 -18:30



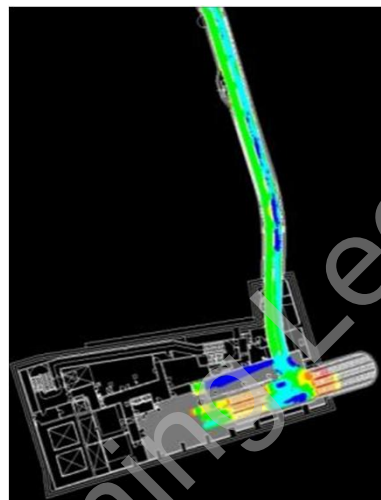


## PM Peak 2026 +21% - Intermediate Level (walking)

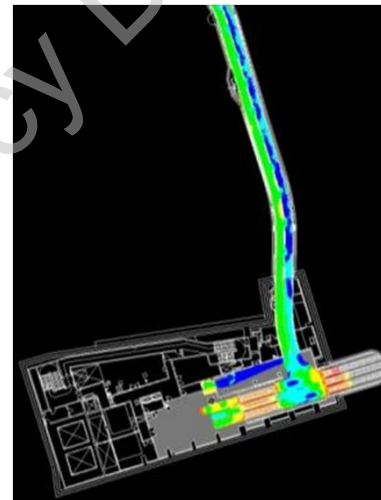
17:30 - 17:45



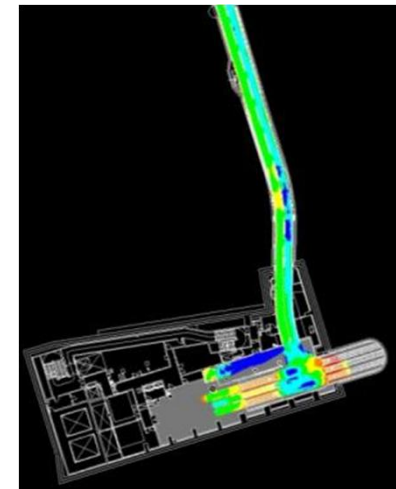
17:45 - 18:00



18:00 - 18:15



18:15 - 18:30

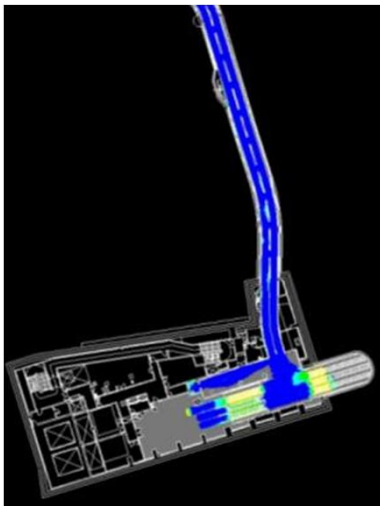


Learning Legacy Document

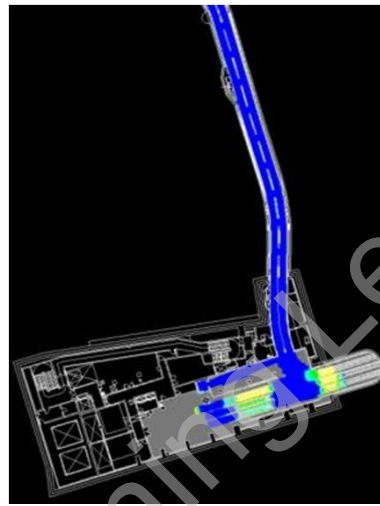


## PM Peak 2026 +21% - Intermediate Level (queuing)

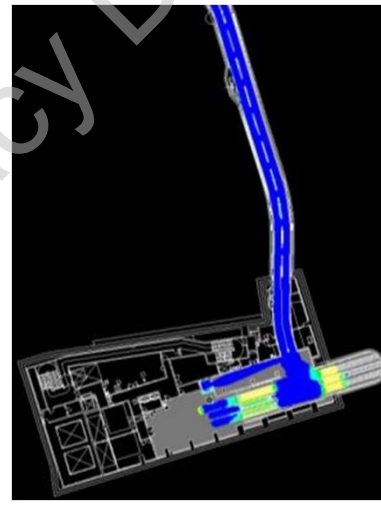
17:30 -17:45



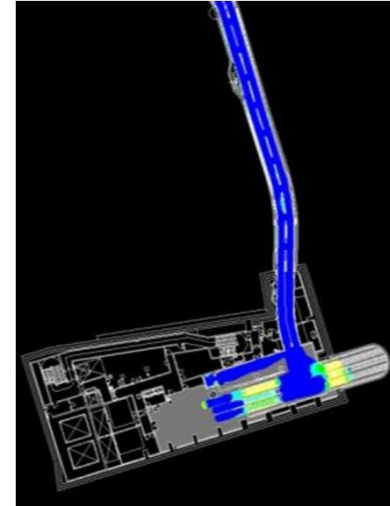
17:45 -18:00



18:00 -18:15



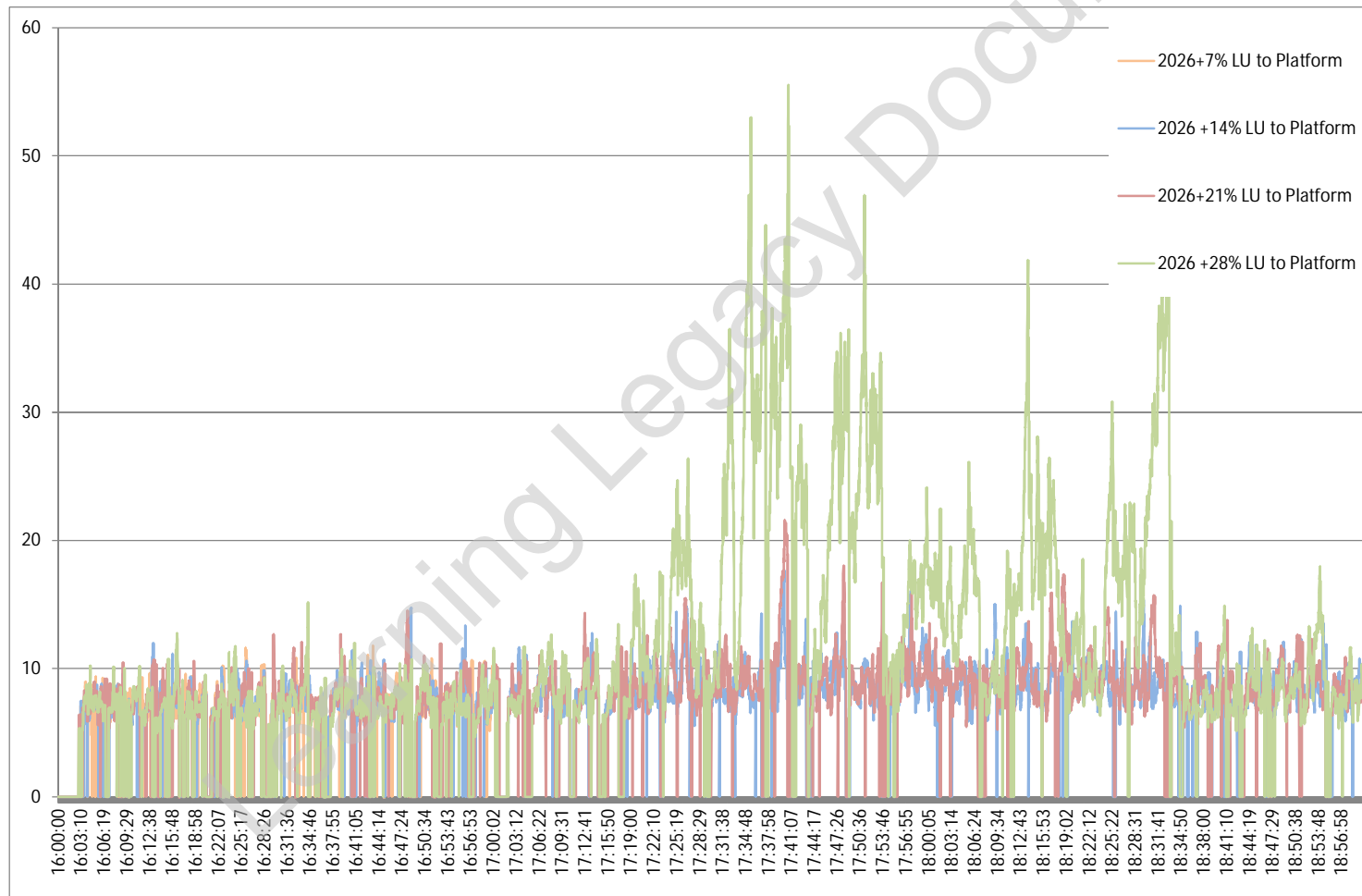
18:15 -18:30



Learning Legacy Document

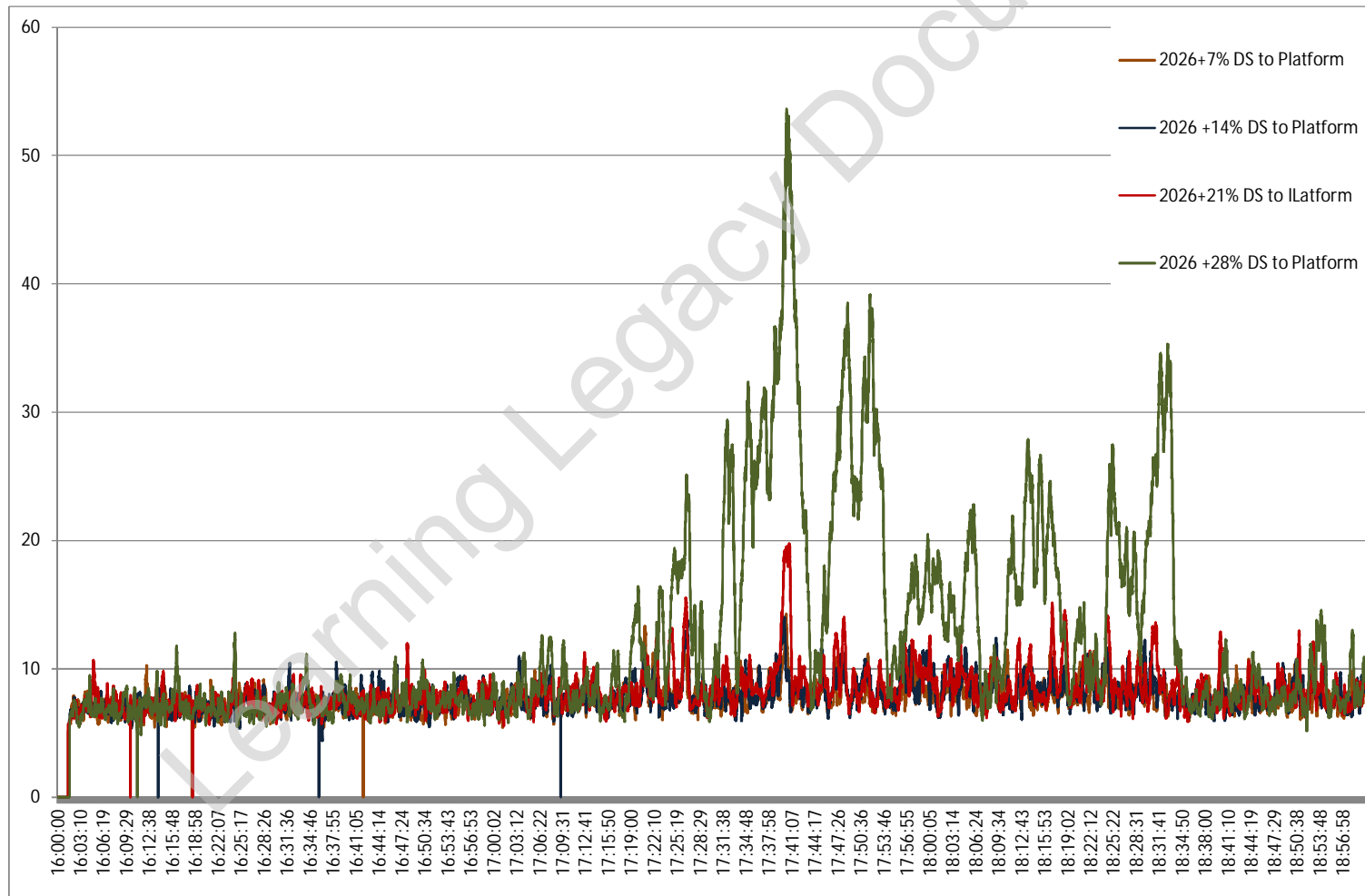


## PM Peak - Intermediate Level (journey time)





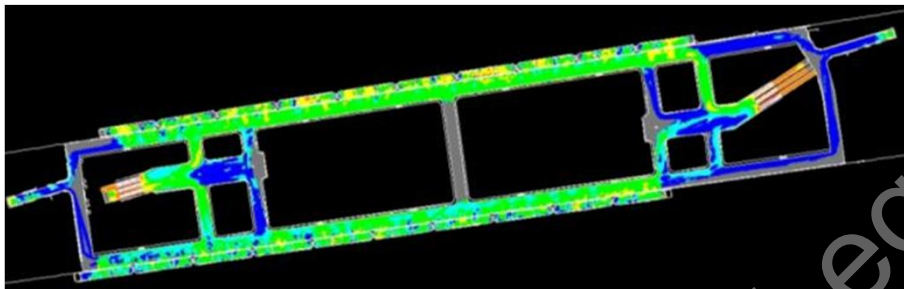
## PM Peak 2026 - Intermediate Level (journey time)



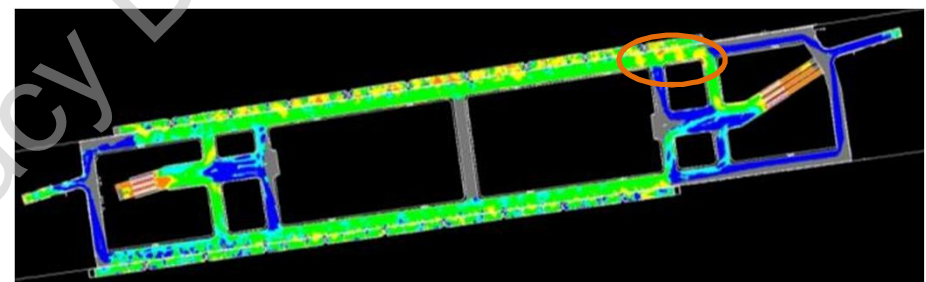


# PM Peak 2026 +21% - Platform Level (walking)

17:30 -17:45

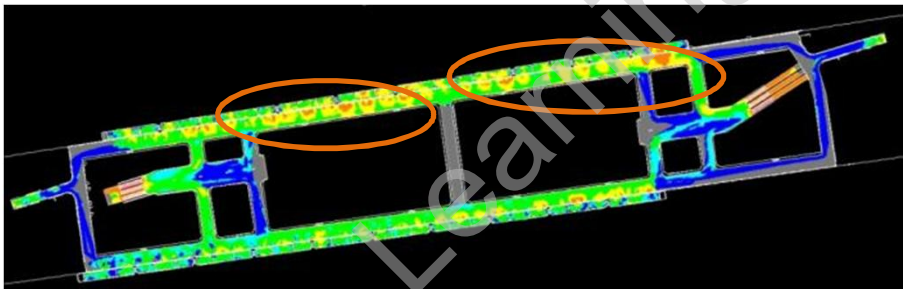


18:00 -18:15



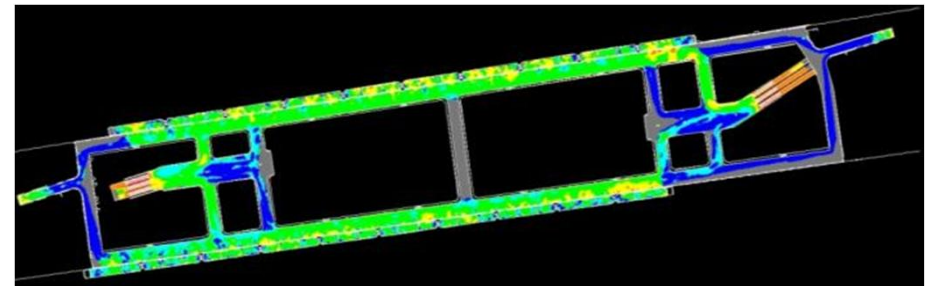
Area= 18sq/m (2% of platform area)

17:45 -18:00



Area= 100sq/m (11% of platform area)

18:15 -18:30

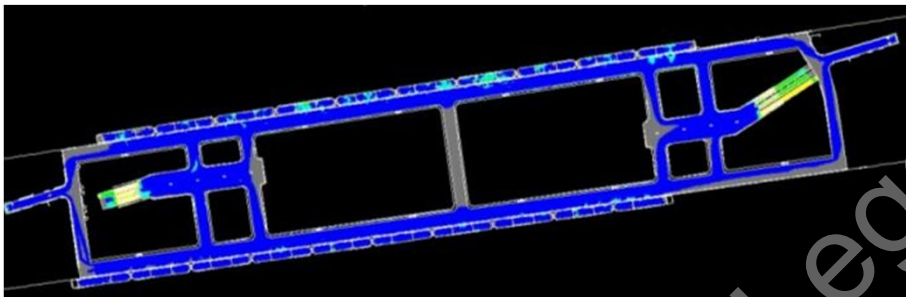




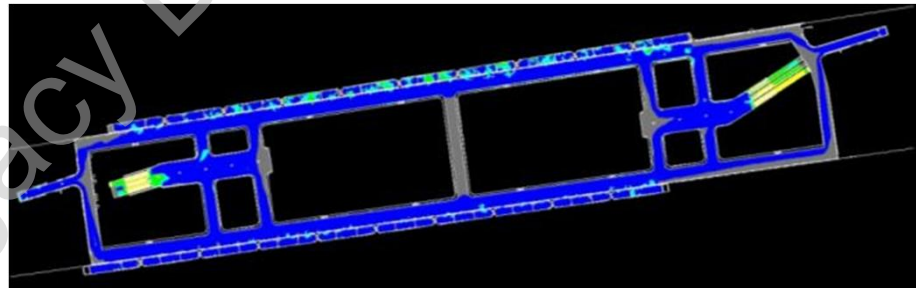


## PM Peak 2026 +21% - Platform Level (queuing)

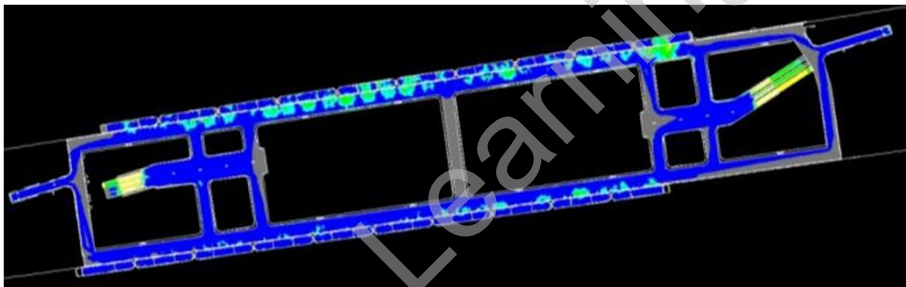
17:30 -17:45



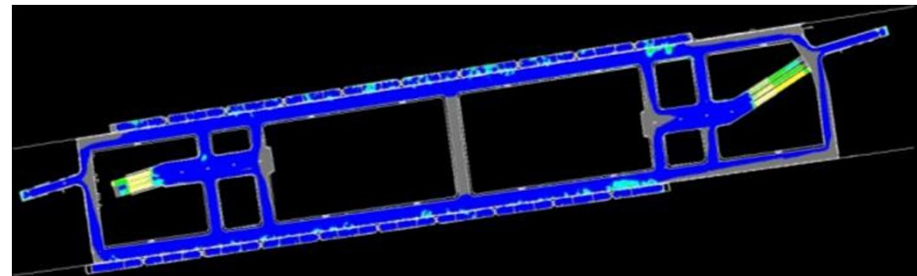
18:00 -18:15



17:45 -18:00



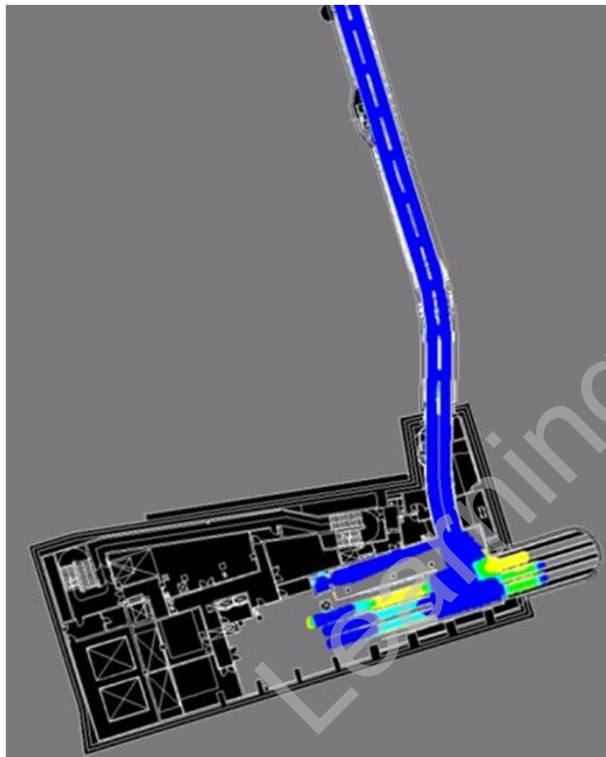
18:15 -18:30



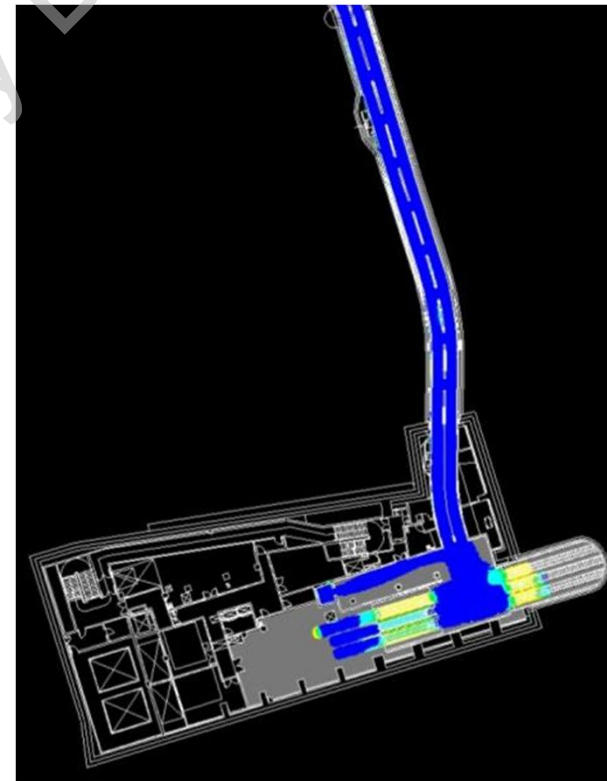


## LoS Queuing Flow Plots Differences

Shown on 5<sup>th</sup> July  
(from PM 2026+28%)



Shown on 13<sup>th</sup> July  
(from PM 2026)





## PM Peak 2026 – Intermediate Level





## PM Peak 2026 – Intermediate Level



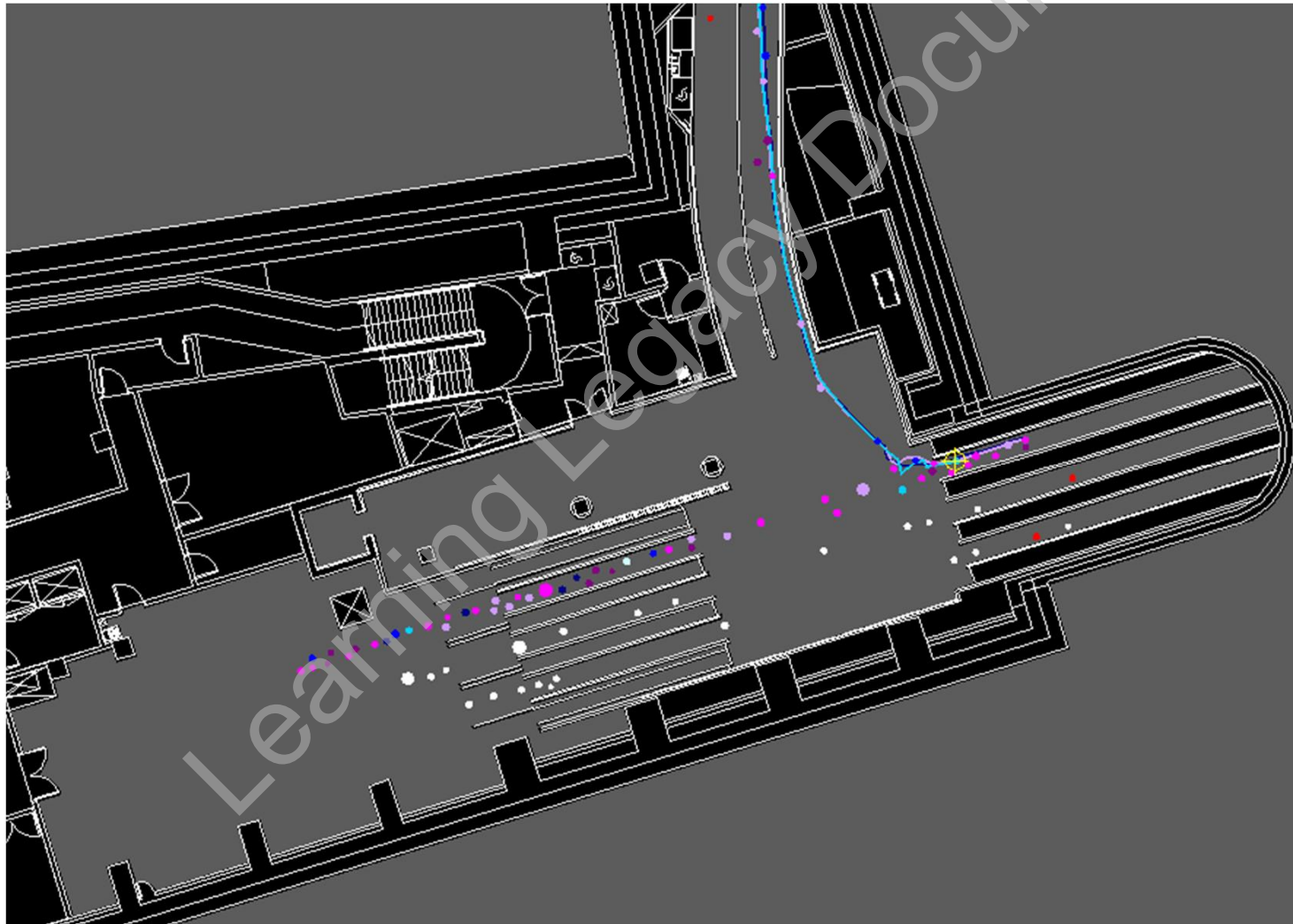


## PM Peak 2026+28% – Intermediate Level





## PM Peak 2026+28% – Intermediate Level



**Gao, Jing**

---

**From:** Palmer, Christine  
**Sent:** 29 July 2011 14:43  
**To:** 'Duff Robert'  
**Cc:** Harmer Charles (Crossrail); Jem Biggins (JemBiggins@crossrail.co.uk); Peet, Tim  
**Subject:** RE: Bond Street Pedestrian Modelling  
**Attachments:** Hanover Square Impact Study June 16.pdf

Hi Rob

Thanks for your e-mail. On the presentation that we prepared for the meeting on 16th June it highlighted that Hanover Square is non-compliant in 2026, see the pdf slides attached highlighting the issue in 2026. We have these model files still so let me know if we'd need to provide anything else within the final report.

With regards the November audit the ticket vending machine had the 15s delay, but this wasn't picked up in the November audit. Thanks for your advice on the train stopping position for the AM peak.

Thanks and have a good weekend.

Christine

-----Original Message-----

**From:** Duff Robert [mailto:Robert.Duff@tube.tfl.gov.uk]  
**Sent:** 29 July 2011 13:30  
**To:** Palmer, Christine  
**Cc:** Harmer Charles (Crossrail)  
**Subject:** RE: Bond Street Pedestrian Modelling

Hi Christine

Very quickly...

Looks like you've identified the breakpoints pretty well. Jem did ring me last week to speak about a potential break point at Hanover Square with the mitigation to send Non-PRM's to the WAG. Not as severe as the intermediate concourse and platform level but really something that should have followed the same procedure. Without undergoing any further model iterations is there any previous work you've done that can suggest what this break point could be? e.g. did it work in 2026?

Vending Machines -I've not had time to take the 15s back up to 45s to determine the impact just yet... sorry. I can't envisage this having a large impact on the CMD plots though. Can you remind me in the November 2010 audit whether 15s was in there or whether this was introduced after?

AM Peak stopping positions; you'll clearly be making the situation better by moving the stopping positions to mirror what is in the PM Peak models. If it's already compliant in the AM Peak then I think all you need is note for someone (e.g. on ACS) who might be using the model at a later date to remind them to make slight modifications to the model before starting to use it [and even then that is if there problem area is the platform level...]

Hope that makes sense

Back in the office now on Tuesday.

Rob

---

From: Palmer, Christine [Christine.Palmer@WSPGroup.com]

Sent: 26 July 2011 13:07

To: Duff Robert; Harmer Charles (Crossrail)

Cc: JemBiggins@crossrail.co.uk; Peet, Tim; Adams Isabelle; Ng, Victoria

Subject: RE: Bond Street Pedestrian Modelling

Hi Rob/ Charles

Following our meeting last week I wanted to just summarise what we discussed and agreed. Please find attached the updated presentation that we went through last week. I have made the changes and additions as you suggested. This basically highlights that the breakpoints are:

- Between 2026+21% and 2026+28% for the Intermediate Level
- 2026+14% for the Platform Level

This is what we will report in our Final Report, can you confirm that you agree with the above?

Just a few queries I'd like to close out.

Ticket Vending Machines – Rob can you confirm whether you want us to change anything?

AM Model – just to confirm the train stopping position will be moved to the revised position that we have adopted in the PM peak and the boarding profiles sent through to us by Crossrail on 18th April

We would appreciate it if you could confirm the above by the end of this week (COP 29th July).

I don't think it is necessary for me to come and meet you tomorrow to go through anything, but please let me know if you think this would be useful. If you have any questions on the above or the attached please let me know.

Kind Regards

Christine

From: Palmer, Christine

Sent: 18 July 2011 16:20

To: 'Duff Robert'; Harmer Charles (Crossrail)

Cc: JemBiggins@crossrail.co.uk; Peet, Tim; Adams Isabelle; Ng, Victoria

Subject: RE: Bond Street Pedestrian Modelling

Hi Rob/ Charles

Following our meeting last week I thought I'd summarise what we agreed:

Hanover Square TH – To confirm all NON PRM's have the choice of using UTS gate or WAG with their choice being based on the fewest occupants at the ticket gates. This will remain the same in final model runs.

Davies Street TH – NON PRM's do not to have the option of using WAG's, consistent with CRL Pedestrian Modelling Guidelines.

Ticket Vending Machines – Leave as it is at the moment. Rob to let us know if any changes should be made.

Lift Logic – Changes made to the lift coding in the model in November was following advice from C132 lift engineer. I've gone back and looked through our spreadsheets and the dwell time at each level is 30 seconds. We've also amended the travel times from each level to be more accurate with the distance between the levels, following advice from our lift expert. I shall make sure that in our final Legion report we add some commentary on the changes made if that's ok?



Platforms – ACS to be updated.

CAD – No changes to be made apart from making it clear which are the SIMULATION and PRESENTATION Layers.

Adit Split – 85%/15% to be used in final Legion model runs.

ASC – To be completed thoroughly for final model handover.

Break Point Modelling

Still continuing results will be extracted ready for our meeting on Wednesday afternoon.

Fire Escape Stairs (from Intermediate Level to Platform level) – I've completed some static analysis on the stairs that go from Intermediate Level to platform level. In the latest CAD the stairs are 2m wide (there is no handrail in the middle of them). The flow from LU to EB and WB platform in the PM peak 2026+28% is:

- LU to CR Eastbound Platform 2304
- LU to CR Westbound Platform 1344
- Total demand 3648

With this demand assuming all pedestrian demand from LU to CR uses the stairs there would be 28.66ppm or LoS C (stairway Level of service) assuming an edge effect of  $0.4572 * 2 = 0.9144$ .

So the stairs can accommodate all pedestrians going from LU to Crossrail if required.

I'll come over to Albany House to catch up with you both at 3:40 this Wednesday again if that's ok?

Any questions before this please let me know.

Kind Regards

Christine

From: Duff Robert [mailto:Robert.Duff@tube.tfl.gov.uk]

Sent: 08 July 2011 16:07

To: Palmer, Christine; Harmer Charles (Crossrail)

Cc: JemBiggins@crossrail.co.uk; Peet, Tim; GilesGrange@crossrail.co.uk; Nanu Sajana (LUL); Adams Isabelle

Subject: RE: Bond Street Pedestrian Modelling

Hi Christine

My responses in Red below. Can probably go through them in person on Wed.

Have a nice weekend.

Rob

-----Original Message-----

From: Palmer, Christine [mailto:Christine.Palmer@WSPGroup.com]

Sent: 07 July 2011 16:07

To: Harmer Charles (Crossrail); Duff Robert

Cc: JemBiggins@crossrail.co.uk; Peet, Tim; GilesGrange@crossrail.co.uk

Subject: Bond Street Pedestrian Modelling Charles/ Rob

Following on from Tuesday's meeting I wanted to ensure that we were clear on the way forward so I've answered the queries highlighted and set out what I understand we should be doing following our post meeting chat.

#### Responses to Questions raised on Tuesday and LU Note

Hanover Square TH - I've checked the model we provided you and Non PRM's can use the WAGs at Hanover Square. All PRM's have the choice of using the WAGs at Hanover Square. We will revise location of Focal Nodes. How exactly are Non-PRM's directed to use the WAGs at Hanover Sq? Is a specific proportion sent to the WAG at all times or do these passengers only use the WAGs when the standard UTS route gets overcrowded?

Davies Street TH – I assume that we should amend coding to be consistent with Hanover Square (i.e. Non PRM's having the choice to use WAGs), can you advise? I would advise to leave alone if Davies Street is not an issue to avoid too many changes to model. This is consistent with the CRL Pedestrian Modelling Guidelines. Hanover Sq will have to be the exception (but would be good to know the precise logic, e.g only at extremely busy times do Non-PRMs use the WAG? ( See above ).

Ticket Vending Machines – The reason we used different transaction times (a TVW of 20, 45, 75 and TOP of 10, 15, 30 (assumed to be FFM from conversation with Architects)) is because of the CAD drawings we were provided by our Architects, see screenshot below of ticket machines in Davies Street ticket hall. Let me know if you want this to be revised in our models. Ticket machine buying behaviour appears to have very little impact as things stand on both ticket halls (chiefly the lower LOS colours from memory at +28% with 6% of passengers using the machine?). This was more for clarity. There are 5 machines in each ticket hall. I'm not up to speed with future ticketing but has there been a decision to split these 5 machines into sub-types? if so would TVM's be more popular than TOPs? They are equally attractive in your model.

[cid:image001.jpg@01CC4B85.BB3359A0]

Lift Logic – following the LU Audit in November we revised the lift profiles in the model following advice from our lift expert, which resolved the queuing of PRM's at Intermediate level. I can provide further detail if required. We will include our responses to the LU audit in our final report, let me know if you'd like to see them beforehand. it would be good to let us know what the changes you made in the model were to make this area work all of a sudden. Floor Dwell time reduction from 40s? 30s may be possible, unlikely anything less than 30s would be possible??

Platforms – will update cover sheet with revised boarding distribution . ACS needs to reflect model so this needs updating. The base models will be stored on LU servers to be used into the future and beyond so the assumptions need to be clear at a glance and accurate.

CAD - will go through all the CAD layers and remove all the unnecessary ones for the final report. Not important to do so don't waste time, just be clear on which are the SIMULATION and PRESENTATION Layers.

Adit Split – was 60%/40% for the Western Ticket Hall following previous model runs (prior to the new revised matrix) from our conversations on Tuesday we shall revert back to 80%/15% for all adit splits. Revert back to 85:15 as per the originally agreed LU/CRL assumption (85:15 with revised splits actually led to better platform density)

ASC – comments noted and will be updated accordingly. Thanks, ACS acts as a useful guide when auditing, spot checking a model. But version control tab needs to be pretty comprehensive in reflecting the changes made from the previous ACS.

#### Break Point Modelling

As discussed we shall re-run the break point modelling uplifting from the PM 2026 model (instead of down from PM 2026+28% as previously advised by Charles).

Breakpoint modelling should use the 2026 BASE model (i.e. with 24TPH - with cancelled train in EB direction in PM Peak) Firstly, run 2026+14% - if fail then run 2026+7%... intention is to tell use approximately when the station becomes non-compliant (for example the conclusion may be some time between 2026+7% and 2026+14% - this

range is sufficient) \*also see attached flow char If you can confirm the queries I have above these models will be run and outputs extracted ready for Wednesday afternoon.

I am available on Wednesday afternoon at around 14:30/15:00 to meet up so we can discuss the following: I'm free too, do come in to AH when Charles is also here to seek clarity on anything.

- Any outstanding issues from LU audit
- Results of break points (+14% and +7%) uplifting from a 2026 base
- Analysis of areas of non-compliance for 2026+28%/ 2026+14%/ 2026+7% (platforms/ Intermediate level)

Please let me know if you have any comments on the above

Kind Regards

Christine

Christine Palmer  
Senior Engineer, Property & Development

WSP House, 70 Chancery Lane, London, WC2A 1AF  
Tel: +44(0)20 7314 4640

Website: [www.wspgroup.com](http://www.wspgroup.com)<<http://www.wspgroup.com/>>

We are WSP. United by our difference.

NCE/ ACE International Consultant of the Year 2011 Number 1 Transport Consultancy 2011 (NCE Consultants File)

Click here<<http://www.wspgroup.com/en/Welcome-to-WSP-UK/Careers1/Careers2/What-we-do-UK/story-telling-UK/>> to hear stories from our WSP people.

WSP is one of the world's fastest-growing design, engineering and management consultancies. Specialising in property, transport and environmental projects, we work with clients to create built and natural environments for the future.

**CONFIDENTIAL**

This e-mail is confidential to the named recipient. If you have received a copy in error, please destroy it. You may not use or disclose the contents of this e-mail to anyone, nor take copies of it. The only copies permitted are (1) by the named recipient and (2) for the purposes of completing successful electronic transmission to the named recipient and then only on the condition that these copies, with this notice attached, are kept confidential until destruction.

WSP UK Limited Registered Office: WSP House, 70 Chancery Lane, London, WC2A 1AF Registered Number 01383511 England

\*\*\*\*\*

The contents of the e-mail and any transmitted files are confidential and intended solely for the use of the individual or entity to whom they are addressed. Transport for London hereby exclude any warranty and any liability as to the quality or accuracy of the contents of this email and any attached transmitted files. If you are not the intended recipient be advised that you have received this email in error and that any use, dissemination, forwarding, printing or copying of this email is strictly prohibited., If you have received this email in error please notify



16<sup>th</sup> June 2011

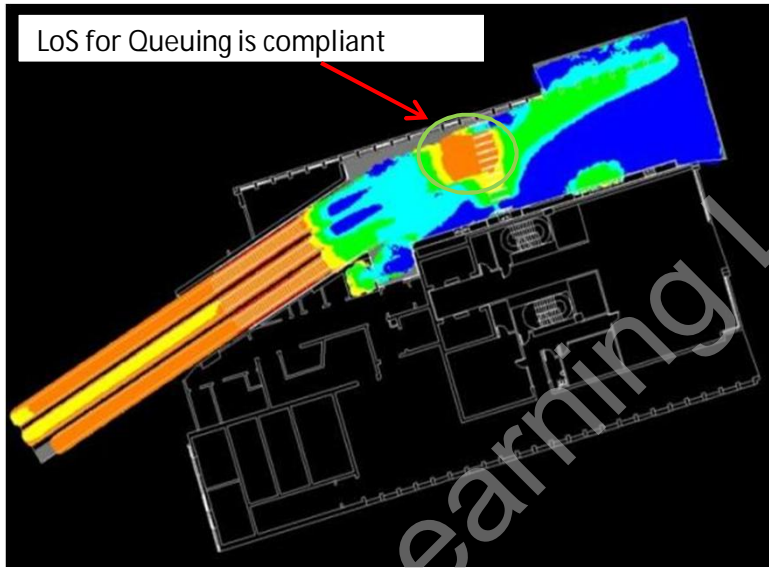
# 2026 Non Compliances – 2 Up 1 Down WTH and ETH

Escalator Configuration at WTH and ETH – 2 Up, 1 Down

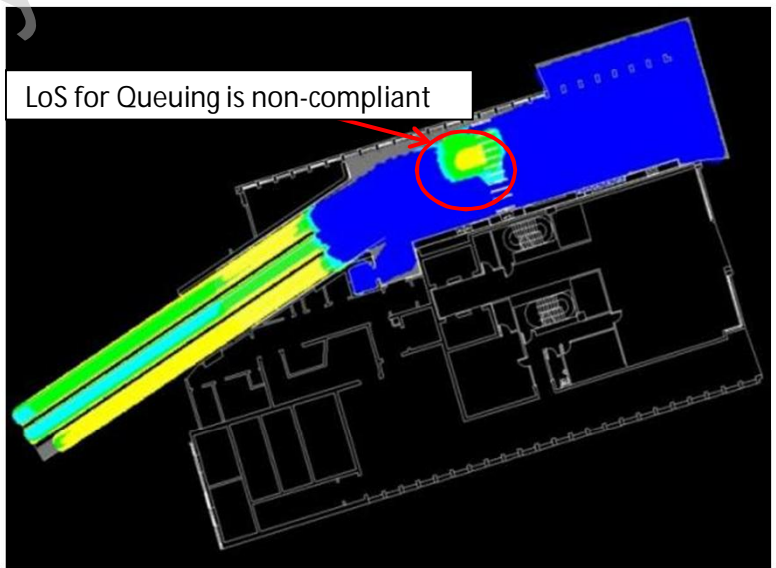
PM Peak 2026 (17:45-18:00)

## The Results

Walking Level of Service



Queuing Level of Service



	17:30-17:45	17:45-18:00	18:00-18:15	18:15-18:30
Walking Level of Service	C	C	C	C
Compliant?	✓	✓	✓	✓

	17:30-17:45	17:45-18:00	18:00-18:15	18:15-18:30
Queuing Level of Service	C	D	C	D
Compliant?	✓	✗	✓	✗



16<sup>th</sup> June 2011

# 2026 Non Compliances – 2 Up 1 Down WTH and ETH, Revised Ticket Gates

Escalator Configuration at WTH and ETH – 2 Up, 1 Down

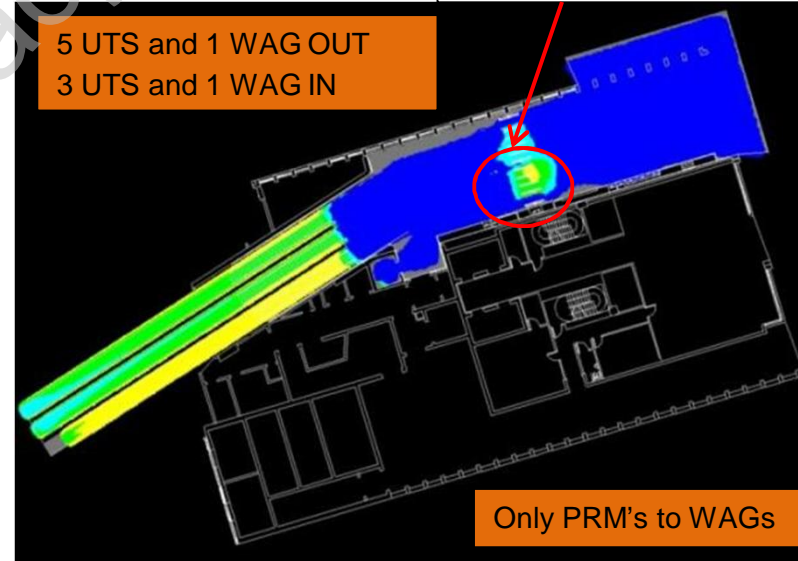
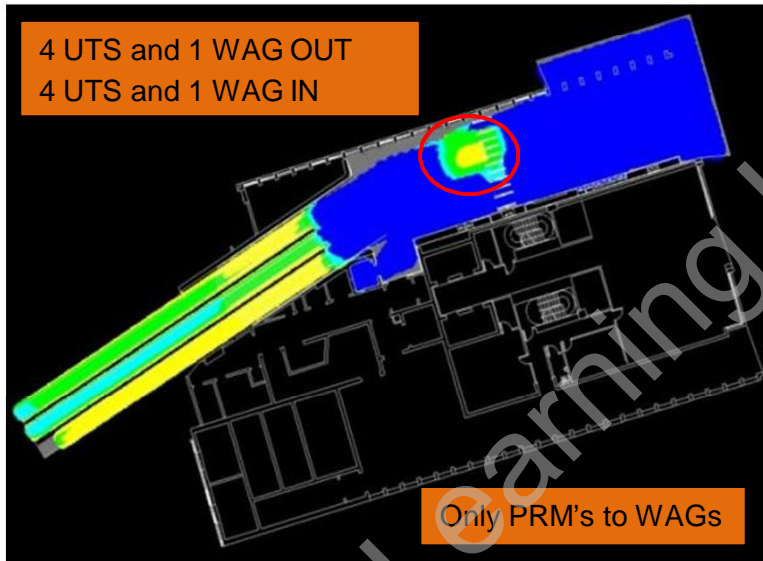
PM Peak 2026 (17:45-18:00)

## The Problem

Queuing Level of Service

## The Results

LoS for Queuing is non-compliant



	17:30-17:45	17:45-18:00	18:00-18:15	18:15-18:30
Queuing Level of Service	D	D	C	C
Compliant?	x	x	✓	✓



16<sup>th</sup> June 2011

# 2026 Non Compliances – 2 Up 1 Down WTH and ETH, Revised Ticket Gates

Escalator Configuration at WTH and ETH – 2 Up, 1 Down

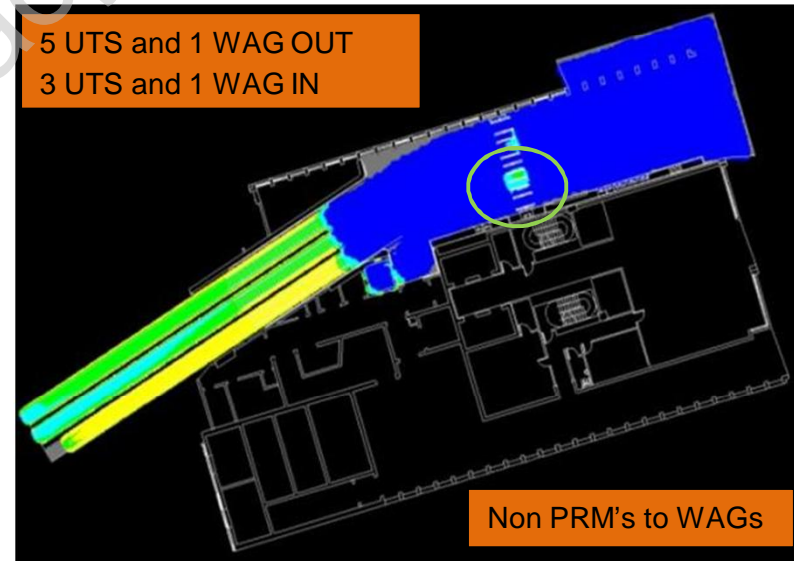
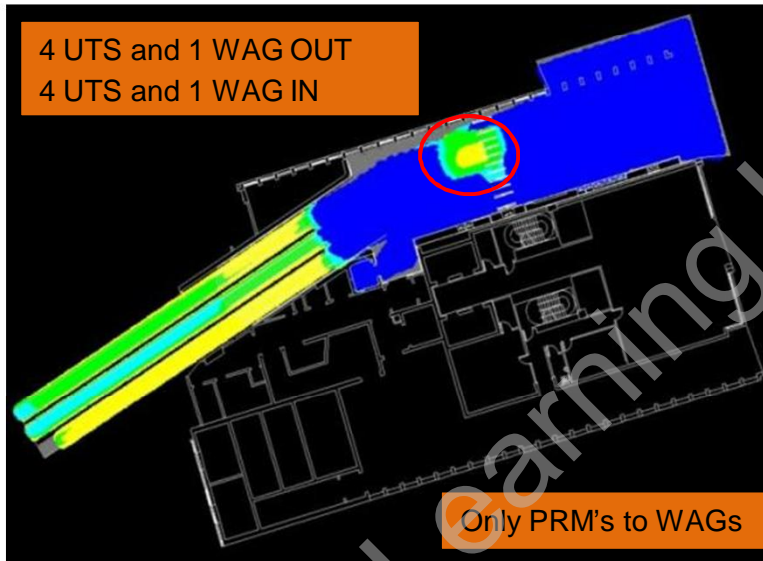
PM Peak 2026 (17:45-18:00)

## The Problem

Queuing Level of Service

## The Results

LoS for Queuing is compliant



	17:30-17:45	17:45-18:00	18:00-18:15	18:15-18:30
Queuing Level of Service	C	C	C	B
Compliant?	✓	✓	✓	✓



**Appendix N – Fire Escape Stairs**

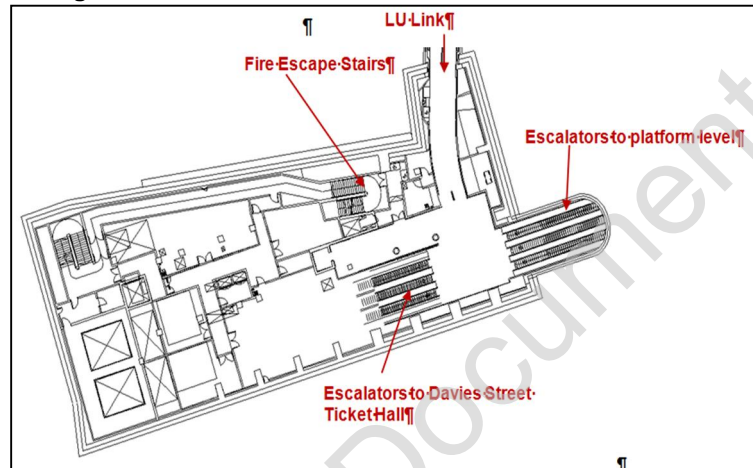
Learning Legacy Document

# PM 2026+28% Fire Escape Stairs Model Run

## INTRODUCTION

The Intermediate level at Crossrail Bond Street Station connects the platform level, Davies Street Ticket Hall and the LU link to the Bond Street London Underground (Central and Jubilee Line) as shown in Figure 1.

**Figure 1: Crossrail Bond Street Station: Intermediate Level**



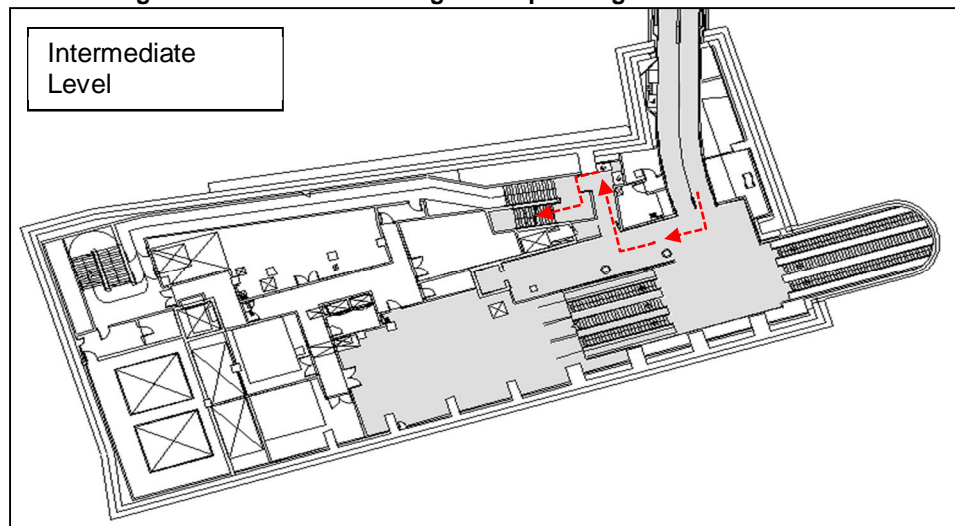
Interchanging passengers from LU will access the Intermediate level via the LU Link before taking the escalator to the Platform level.

In the PM 2026+28% scenario, the C132 Final Bond Street Pedestrian Modelling report it was identified that the fire escape stairs need to be used by the pedestrians from the LU Link due to overcrowding at the Intermediate Level. This will alleviate the high pedestrian density that is experienced at the Intermediate level during this scenario. This Appendix sets out details and results of the modelling work completed.

## ALTERNATIVE ROUTEING

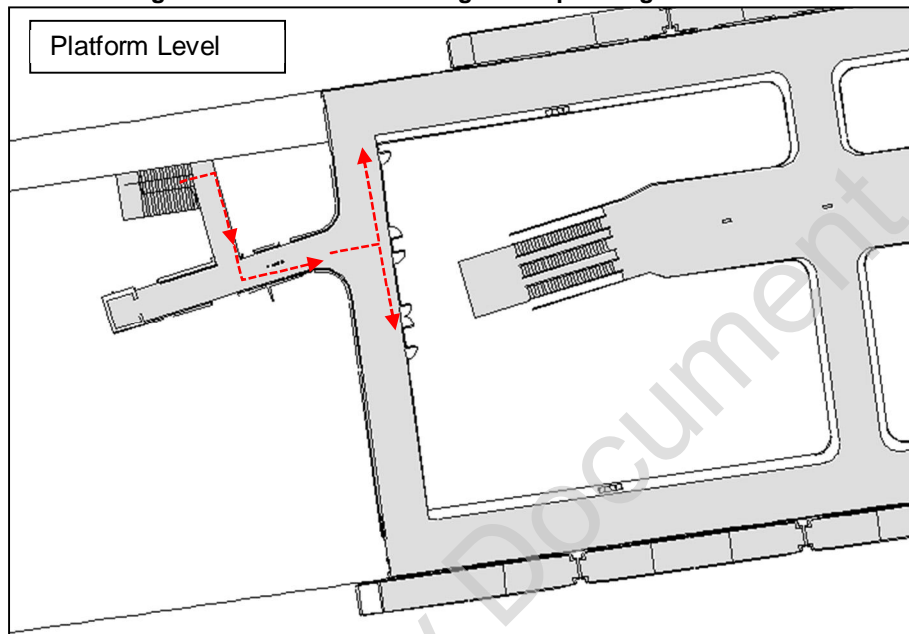
Figure 2 and Figure 3 show the alternative route taken by the passengers arriving from the LU Link. Instead of turning left and taking the escalator down to the Platform level, LU passengers will use the fire escape staircase on the right to access the Platform level.

**Figure 2: Alternative Routing for LU passenger at Intermediate Level**





**Figure 3: Alternative Routing for LU passenger at Platform Level**



#### MODELLING ASSUMPTIONS

In this model, LU passengers will arrive at the Platform via the fire escape staircase and the passageway at the western-most end of the Platforms. Their carriage boarding profiles remain the same as if they arrive at the Platforms via the escalators and adits.

It should not be forgotten that the fire stairs could also be used in both directions if necessary when escalators are being maintained between the Platform, Intermediate level and Ticket Hall level.

#### RESULTS

The following section summarises and compares the Intermediate level and Platform level results with and without the fire escape stairs being used as an alternative route for passengers from the LU. Figure 4 illustrates the density experienced on the fire escape stairs is LoS C, the level of density predicted statically in Chapter 5 of the main report.

**Figure 4: PM Peak 2026+28% Stage E Fire Escape Stairs Cumulative Mean Density Walking and Queuing**

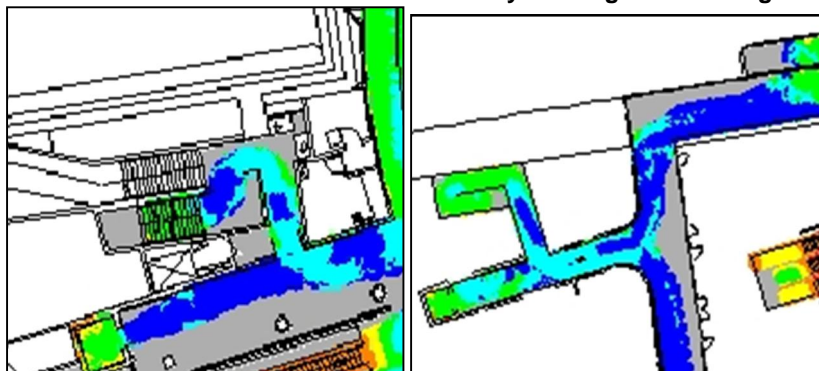


Figure 5 and Figure 6 respectively show the PM 2026+28% walking level of density maps for the Intermediate level, of the Stage E design and Stage E design with the use of the fire escape stairs. The main difference between the maps is an improvement in Level of Service at the top of the escalator to the Platform level. The Level of Service for walking improved from LoS F to LoS C when the fire escape staircase used by LU passengers.

**Figure 5: PM Peak 2026+28% Stage E Intermediate Level  
Cumulative Mean Density Walking**



**Figure 6: PM Peak 2026+28% Stage E with Fire Escape Stairs Intermediate Level  
Cumulative Mean Density Walking**

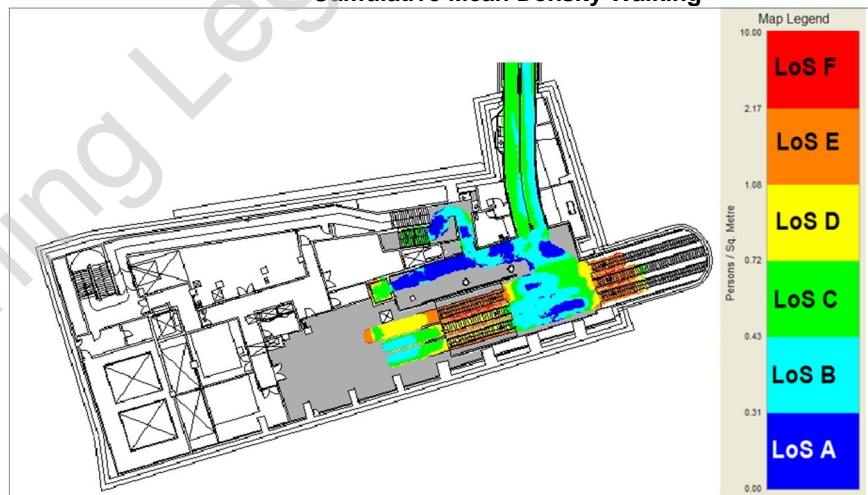
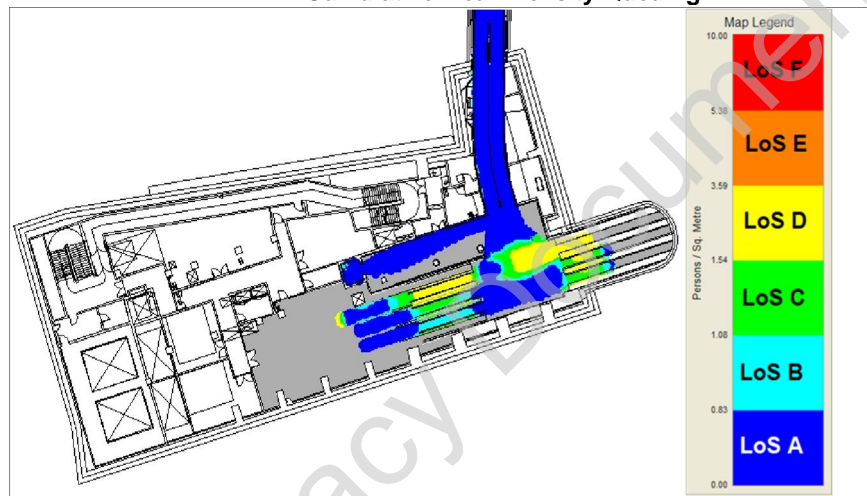
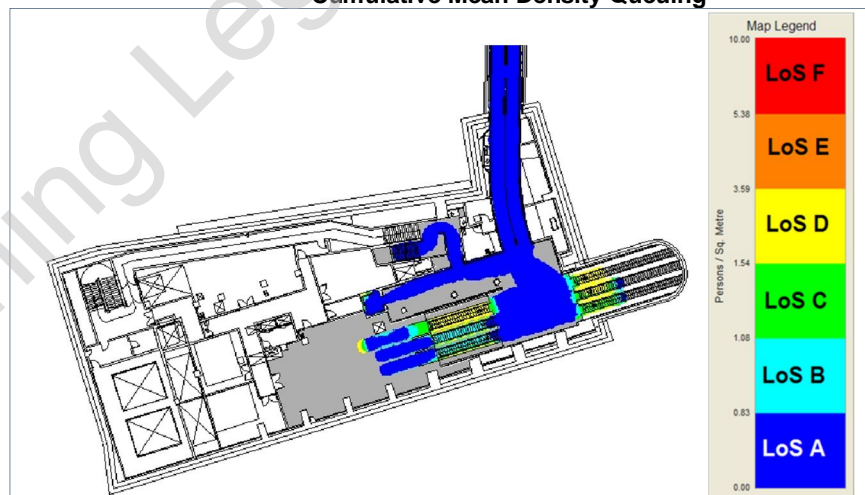


Figure 7 and Figure 8 respectively show the PM 2026+28% queuing level of density maps for the Intermediate level, of the Stage E design and Stage E design with the use of the fire escape stairs. The main difference between the maps is an improvement in Level of Service at the top of the escalator to the Platform level. The Level of Service for queuing improved from LoS D to LoS B when the fire escape staircase is being used by LU passengers.

**Figure 7: PM Peak 2026+28% Stage E Intermediate Level Cumulative Mean Density Queuing**



**Figure 8: PM Peak 2026+28% Stage E with Fire Escape Stairs Intermediate Level Cumulative Mean Density Queuing**



1.1.1 Figure 9 and

Figure 10 respectively show the PM 2026+28% walking level of density maps for the Platform level, with and without the use of the fire escape stairs. There is only one difference between the maps. The passageway used by lift users has increased in Level of Service. The passageway operates at LoS A for walking when used only by lift users. With the LU passengers using the fire escape staircase as an alternative route to the Platform level, the passageway operates at LoS B for walking which is still acceptable.

Figure 9: PM Peak 2026+28% Platform Level Cumulative Mean Density Walking

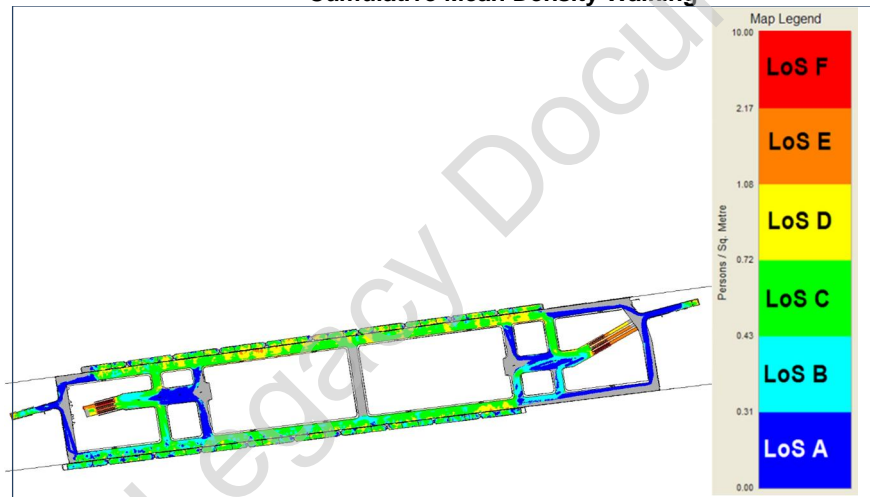


Figure 10: PM Peak 2026+28% Platform Level with alternative routing Cumulative Mean Density Walking

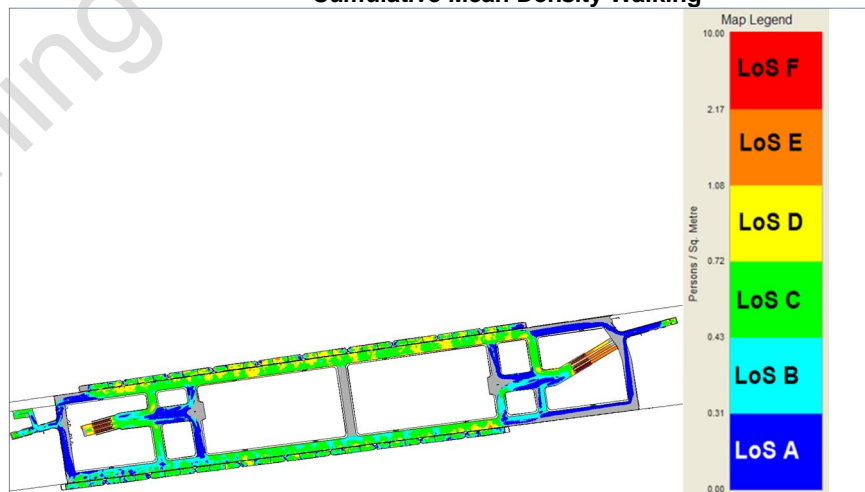


Figure 11 and Figure 12 respectively show the PM 2026+28% queuing level of density maps for the Platform level, with and without the use of the fire escape staircase. There is hardly any difference between the two which is to be expected.

**Figure 11: PM Peak 2026+28% Platform Level  
Cumulative Mean Density Queuing**



**Figure 12: PM Peak 2026+28% Platform Level with alternative routing  
Cumulative Mean Density Queuing**



## CONCLUSIONS

This Appendix presents the findings of pedestrians arriving via the LU Link, using the fire escape stairs to mitigate high levels of density at the Intermediate Level.

Table 1 summarises the differences in Level of Services at the Intermediate level and the Platform level with and without the use of the fire escape staircase. In conclusion, the use of the fire escape staircase as an alternative route for LU passenger relieves the unacceptable levels of density at the Intermediate level whilst the Level of service at Platform level will remain similar.

**Table 1: Intermediate Level Summary of Designs**

Location	LoS Criterion	PM 2026+28%	PM 2026+28%with Fire Escape Stairs
<b>Intermediate Level</b>			
LU passageway	Walking	C	C
Corridor to lift/ fire escape staircase	Walking	A	C
Intermediate Level Run Off Area	Walking	F	C
Top of escalator to platform level	Queuing	D	B
<b>Platform Level</b>			
Passageway from/to Lift	Walking	A	B
Eastbound Platform	Walking	E	E
Eastbound Platform	Queuing	C	C
Westbound Platform	Walking	D	D
Westbound Platform	Queuing	B	B